

PORSCHE SPECIFICATIONS & ADJUSTMENTS

TIRE INFLATION (COLD)

Before attempting to check or adjust wheel alignment, make sure tires are properly inflated. Refer to manufacturer's specifications given in owner's manual.

RIDING HEIGHT

NOTE — Riding height should be set with full tank of gasoline and spare tire included.

All Models (Front) — Checking or adjusting riding height can only be performed with vehicle on level surface. Mark center of front wheel hub cap (grease retainer cup). Bounce vehicle several times to settle suspension. Measure distance "a" as shown in illustration, then measure distance "b". Difference between "a" and "b" should be to specifications. If necessary to adjust, loosen or tighten torsion bar adjusting bolt until correct height is obtained. Bounce vehicle several times and recheck height. **NOTE** — Difference between right and left measurement must not exceed .20".

Riding Height Specifications^①

Application	Front	Rear
911 Series.....	4.21 ± .19"	.468 ± .20"
914 Series.....	3.51 ± .19"	

^① — Measurement is expressed as difference between "a" and "b".

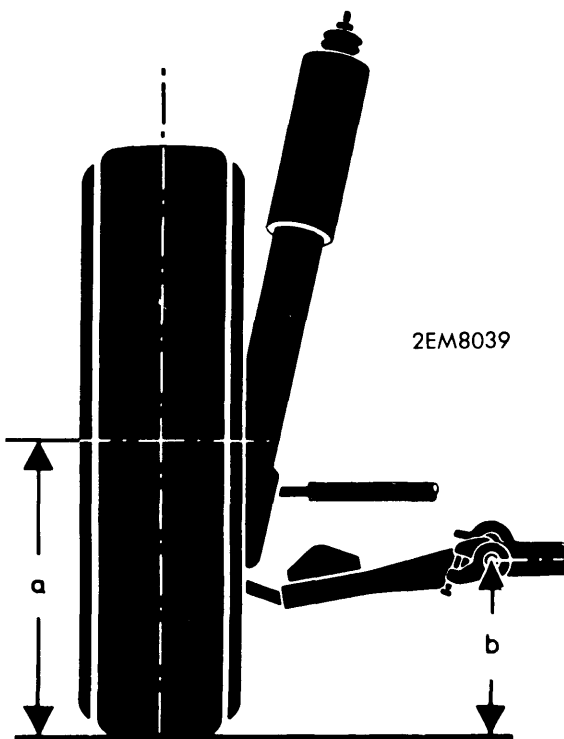

FRONT RIDING HEIGHT DIMENSIONS

911 Series (Rear) — Checking or adjusting riding height can only be performed with vehicle on level surface. Mark center of rear wheel. Bounce vehicle several times to settle suspension. Measure distance "a" as shown in illustration. Distance "a" plus .468" equals "b"; however, distance "b" is difficult to measure because the torsion bar is mounted off center in its rubber bushing. Therefore, it is necessary to measure distance "b 1" and add .585" (radius of bushing). This total should be equal to "b". After calculating "b", difference between "a" and "b" should be .468 ± .20". Difference in height from left to right should not exceed .197". If values are not within specifications, check front height and rear torsion bar adjustment. Correct as required.

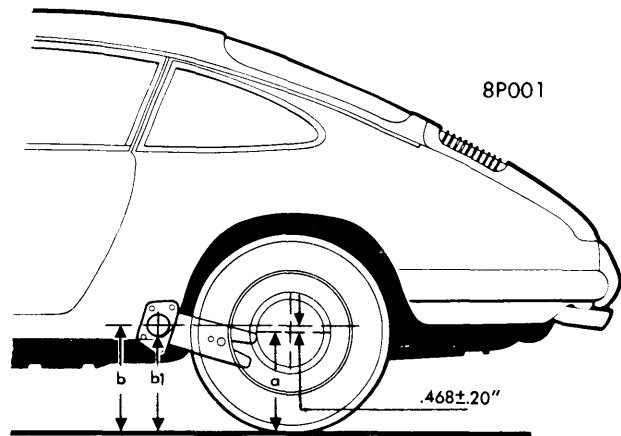

REAR AXLE RIDING HEIGHT DIMENSIONS

CASTER

All Models — If caster angle is not to specifications, it will be necessary to move adjuster plate which attaches to front shock absorber. Remove enough front compartment carpet to allow access to top of each shock absorber. Mark position of each movable plate, located below each Allen screw. Loosen each screw and upper shock absorber nut. Move assembly lengthwise to obtain correct caster angle. Tighten all three screws and shock absorber nut. **NOTE** — Movement of adjuster plate from side to side will affect camber angle.

CAMBER

All Models (Front) — If camber angle is not to specifications, it will be necessary to move adjuster plate which attaches to front shock absorber. Remove enough front compartment carpet to allow access to top of each shock absorber. Mark position of each movable plate, located below each Allen screw. Loosen each screw and upper shock absorber nut. Move assembly from side to side to obtain correct camber angle. Tighten all three screws and shock absorber nut. **NOTE** — Movement of adjuster plates in lengthwise direction will affect caster angle.

911 Series (Rear) — Mandatory prerequisite, for obtaining permissible camber values at rear wheels, is proper adjustment of rear torsion bars. See *Torsion Bar Adjustment*. Loosen nuts on retaining bolts and nuts on eccentric bolt at rear axle flange. Turn camber eccentric until camber angle is within specifications. Tighten retaining nuts and eccentric bolt nuts.

Wheel Alignment

PORSCHE SPECIFICATIONS & ADJUSTMENTS (Cont.)

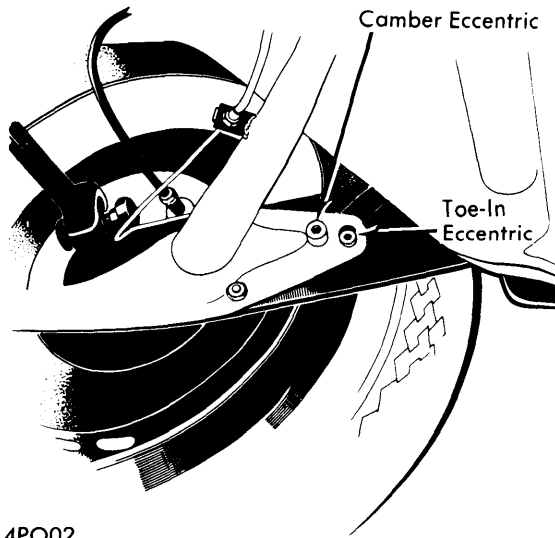

4P002

REAR WHEEL ADJUSTMENT POINTS (911 SERIES)

914 Series (Rear) — Mark position of rear axle control arm on base plate, then remove center bolt attaching base plate to body and loosen remaining base plate attaching bolts. To adjust camber, add or remove shims between base plate and body. Shims are available in the following thicknesses: .079" (2mm), .118" (3mm) and .157" (4mm). *NOTE* — Each .039" (1mm) increment will change camber angle approximately $\frac{2}{3}/6^\circ$. With camber set to specifications, install center attaching bolt and tighten all bolts.

TOE-IN

NOTE — All toe-in specifications are given in degrees.

All Models (Front) — Place front wheels in straight-ahead position. Adjust left and right steering links (tie rods) equally to obtain specified setting. Coat each steering link with anti-corrosive compound after adjustment.

911 Series (Rear) — To adjust rear wheel toe-in, loosen nuts on retaining bolts and adjusting eccentrics at rear axle flange. Turn toe-in eccentric until toe-in is set to specifications. Hold eccentric stationary and tighten all lock nuts.

914 Series (Rear) — To adjust rear wheel toe-in, loosen retaining bolts of rear axle control arm base plate. Move control arm pivot bracket backward or forward until toe-in is within specifications. Tighten retaining bolts and recheck toe-in setting.

TORSION BAR ADJUSTMENT

911 Series (Rear) — Place torsion bar into transverse tube with inner end splines first. Slip radius arm onto outer end splines of torsion bar. Place suitable leveling tool (VW 261) on lower edge of door opening and adjust level so bubble is in center of glass. Check adjustment (degrees) of free hanging radius arm with same leveling tool. If not to specifications, adjust by turning torsion bar and radius arm in opposite directions. Adjustment of both radius arms must each equal $36^\circ 45' \pm 15'$.

WHEEL ALIGNMENT SPECIFICATIONS					
Application	Caster (Degrees)	Camber (Degrees)	Toe-In (Degrees)	Toe-Out On Turns (Degrees)	
				Inner	Outer
911 Series					
Front	$6 \pm \frac{1}{4}$	① $0 \pm \frac{1}{6}$	0°
Rear	$-1 \pm \frac{1}{6}$	③ $\frac{1}{6}^\circ \pm \frac{1}{6}^\circ$
914 Series					
Front	$6 \pm \frac{1}{2}$	② $0 \pm \frac{1}{3}$	$\frac{1}{3}^\circ \pm \frac{1}{6}^\circ$
Rear	② $-\frac{1}{2} \pm \frac{1}{3}$	③ $\frac{1}{8}^\circ \pm \frac{1}{8}^\circ$

- ① — Maximum deviation left to right is $\frac{1}{6}^\circ$.
- ② — Maximum deviation left to right is $\frac{1}{3}^\circ$.
- ③ — Per wheel.