

# Wheel Alignment

## DATSUN SPECIFICATIONS & ADJUSTMENTS

### TIRE INFLATION (COLD)

Before attempting to check or adjust wheel alignment, make sure that tires are properly inflated. Refer to manufacturer's specifications given in owner's manual.

### RIDING HEIGHT

**Pickup Only** — Measure distance from center of lower control arm bushing (where it connects to body) and lower steering knuckle bushing (see illustration). To adjust, raise vehicle to release tension on anchor bolt adjusting nut and turn anchor bolt to adjust to specified height.

#### Riding Height Specifications

Application	Inches (mm)
620 Pickup .....	3.1-3.2 (78-82)

### CASTER

**All Models Exc. Pickup** — Preset at factory and cannot be adjusted. If not to specifications, check suspension for wear or damage and repair or replace components as necessary.

**Pickup** — Caster is adjusted by increasing or decreasing thickness of shims inserted between upper link spindle and upper link mounting bracket. When front shim thickness increases, caster decreases. *NOTE* — Do not adjust caster with difference between front and rear shim thicknesses beyond .078" (2mm).

### CAMBER

**All Models (Exc. Pickup)** — Preset at factory and cannot be adjusted. If not to specifications, check suspension for wear or damage and repair or replace components as necessary.

**Pickup** — Camber is adjusted by increasing or decreasing the thickness of shims inserted between upper link spindle and upper link mounting bracket. When thickness of shims increase, camber decreases.

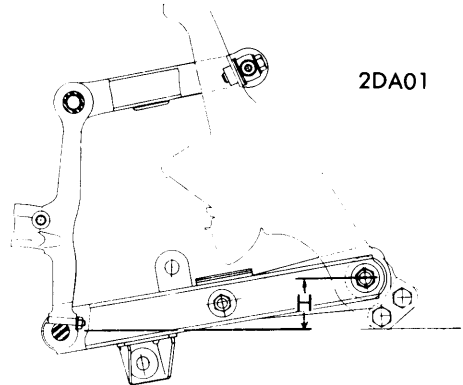

RIDING HEIGHT MEASURING POINT

### TOE-IN

**All Models** — Adjust by loosening each side steering link lock nut and adjusting steering link to change toe-in. *NOTE* — Left and right side steering links should be adjusted equally. Tighten lock nuts.

WHEEL ALIGNMENT SPECIFICATIONS					
Application	Caster (Degrees)	Camber (Degrees)	Toe-In (Inches)	Toe-Out On Turns (Degrees)	
				Inner	Outer
B210	$1\frac{3}{4} \pm \frac{1}{2}$	$1\frac{1}{3} \pm \frac{1}{3}$	$\frac{3}{16}$ to $\frac{7}{32}$	37 to 39	31 to 33
610	$2 \pm \frac{3}{4}$	$2 \pm \frac{3}{4}$	$\frac{7}{16}$ to $\frac{9}{16}$	37 to 38	31 to 33
Sedan	$2 \pm \frac{3}{4}$	$2\frac{1}{4} \pm \frac{3}{4}$	$\frac{7}{16}$ to $\frac{9}{16}$	37 to 38	31 to 33
Wagon	$2 \pm \frac{2}{3}$	$2\frac{1}{6} \pm \frac{3}{4}$	$\frac{9}{16}$ to $1\frac{1}{16}$	37 to 38	31 to 33
710	$1\frac{5}{6} \pm \frac{3}{4}$	$1\frac{1}{4} \pm 1$	$\frac{3}{64}$ to $1\frac{3}{64}$	35 to 37	30 to 32
Pickup	$3 \pm \frac{3}{4}$	$\frac{3}{4} \pm \frac{3}{4}$	$\frac{5}{64}$ to $1\frac{3}{64}$	33 to 34	32 to 33
260Z					