

## TOYOTA

Celica ST  
 Corolla  
 Corona  
 Corona MK II  
 Hi-Lux  
 Land Cruiser

### Brake Pedal Height

Application	Height
Celica ST.....	6 <sup>3</sup> / <sub>8</sub> "
Corolla KE Models.....	5 <sup>3</sup> / <sub>4</sub> "
TE Models.....	6 <sup>5</sup> / <sub>8</sub> "
Corona.....	6 <sup>1</sup> / <sub>2</sub> "
Corona MK II.....	6 <sup>1</sup> / <sub>4</sub> "

### DESCRIPTION

Two brake systems are used; one system utilizing drum brakes on all four wheels, the second system utilizing disc brakes on front wheels and drum brakes on rear wheels. Single or dual piston master cylinders may be used with either system, and a pressure control valve is used on system incorporating disc brakes. Either system may be equipped with a power brake assist unit. All parking brakes are cable actuated, internal expanding shoe type. Land Cruiser parking brake is mounted on rear of the transfer case, all other models use a parking brake incorporated in rear wheel brakes.

### DISC BRAKES

Disc brakes are self adjusting, therefore, no adjustment in service is required.

### DRUM BRAKES

**Manual Adjusting** — One or two adjusting screws may be used on some vehicles. **CAUTION** — On double adjusting screw type, do not adjust both screws at the same time. Pump brake pedal several times, and ensure brake cylinder reservoir is full. Raise vehicle and remove adjusting hole plug from backing plate. Using a suitable adjusting tool, turn adjusting screw until shoes make full contact with brake drum, and wheel will not turn. Pump brake pedal, then turn adjuster back until wheel turns with light shoe drag.

### ADJUSTMENT

#### BRAKE PEDAL HEIGHT

**All Models (Except Hi-Lux & Land Cruiser)** — Loosen stop light switch lock nut and turn switch to obtain correct brake pedal height. If correct height cannot be obtained by adjusting switch, loosen push rod lock nut and lengthen or shorten push rod as necessary to obtain correct height.

**Self Adjusting** — Adjustment, except at time of overhaul, should not be required. If self adjusters are not functioning properly, hold self adjuster screw and perform procedure described under manual adjusting.

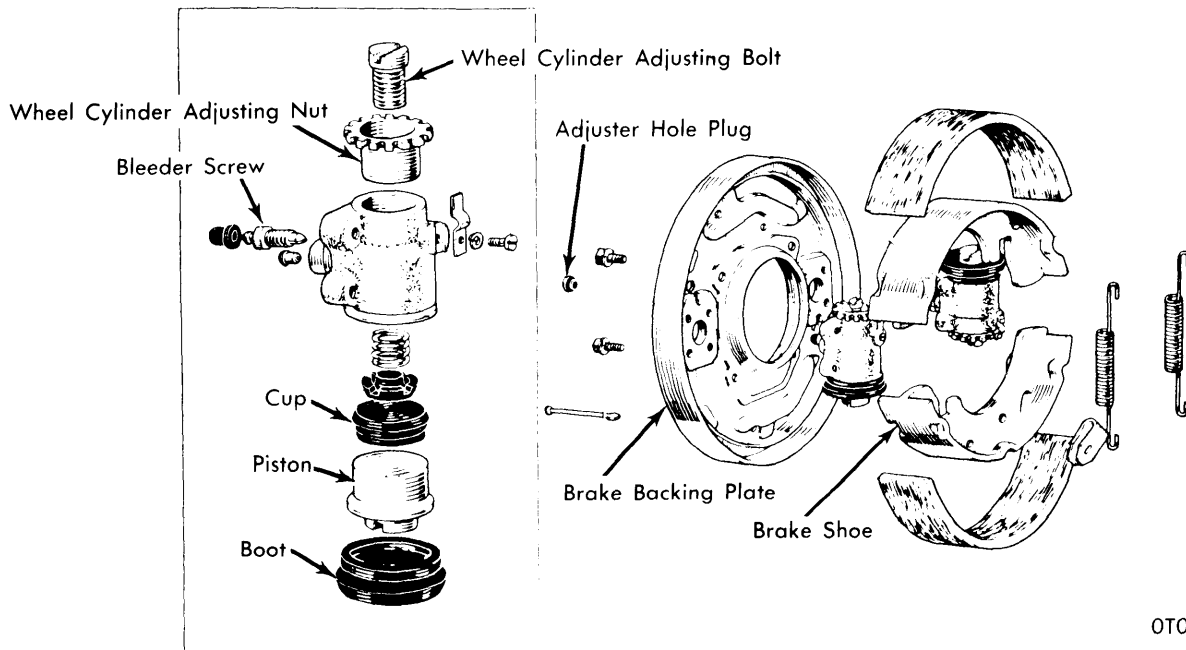

OT015

### DUAL CYLINDER DRUM BRAKE ASSEMBLY

## TOYOTA (Cont.)

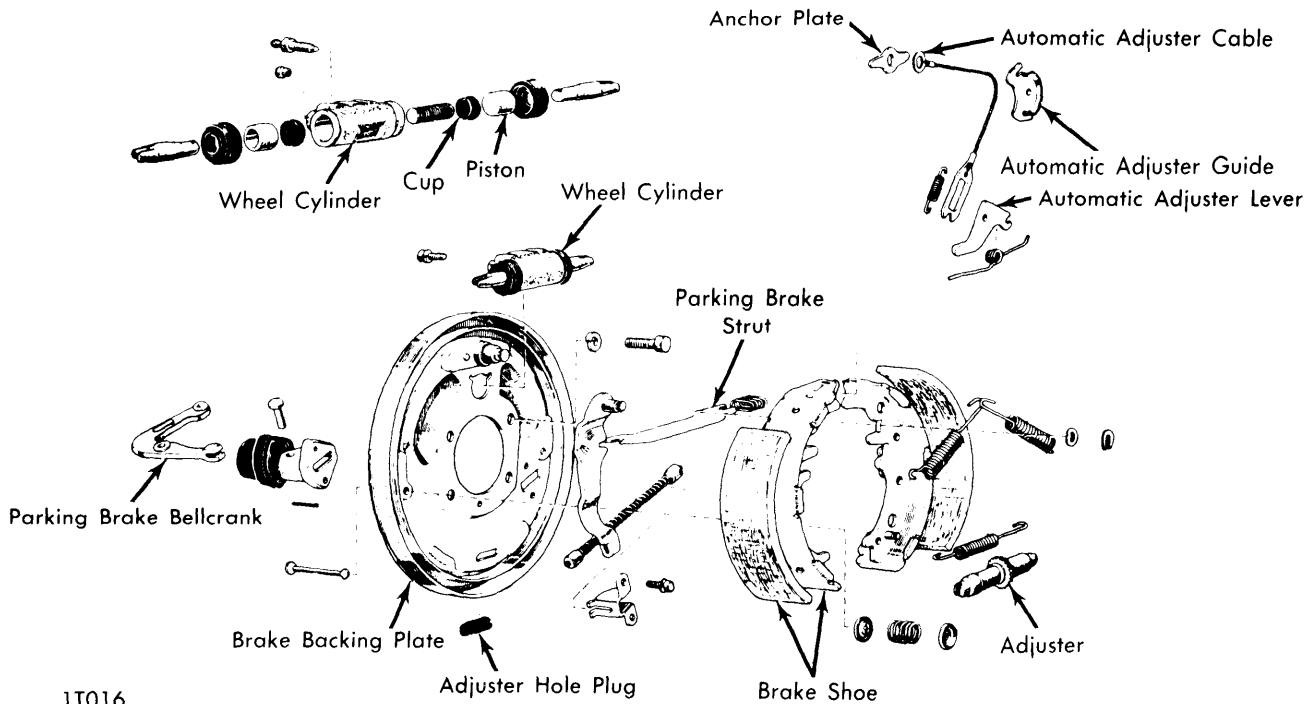

1T016

**SINGLE CYLINDER (DUO SERVO) DRUM BRAKE ASSEMBLY**

### PARKING BRAKE

**Land Cruiser** — With brake handle fully released, turn shaft of adjusting cam (on brake backing plate) counterclockwise until shoe seats against drum. Back off adjuster one notch at a time until drum locks when foot brake is applied, and spins freely when released. After adjusting shoes, adjust brake handle for travel of 6-9 notches from released to applied position. Adjust by turning cable adjusting nut or turnbuckle.

**All Others (Instrument Panel Mounted)** — With brake handle fully released, turn cable adjusting nut at equalizer on frame until cables to rear wheels are slightly slack, and there is no drag on rear wheels. After adjustment, brake handle travel should be about eight notches, and brake warning light should be off. If light remains on, adjust switch position so light is on when brake is applied, and off when handle is released.

**All Others (Floor Mounted)** — Correct adjustment is obtained when rear wheels are locked, and brake lever travel is 5-8 notches. To adjust, remove cable adjusting cap at rear of lever, and turn cable adjusting nut until correct lever travel is obtained. Replace and lightly tighten adjusting cap. Check and adjust brake warning light switch so that light is off when brake lever is released.

### HYDRAULIC BRAKE BLEEDING

**NOTE** — Master cylinder reservoir(s) must be kept full at all times during bleeding. Starting at wheel cylinder farthest from master cylinder, connect a tube to bleeder screw and put other end of tube in a glass container half full of clean brake fluid. Slowly pump brake pedal several times, then hold pedal in depressed position. Open bleeder screw slightly, and close screw when fluid stops flowing from tube. Repeat procedure until fluid coming from tube shows no sign of air.

### REMOVAL & INSTALLATION

#### FRONT DISC BRAKE PADS

**Removal (Celica ST)** — Raise and support vehicle, and remove front wheel. Remove four disc pad clips, then remove caliper guides and caliper. Remove disc pads from caliper.

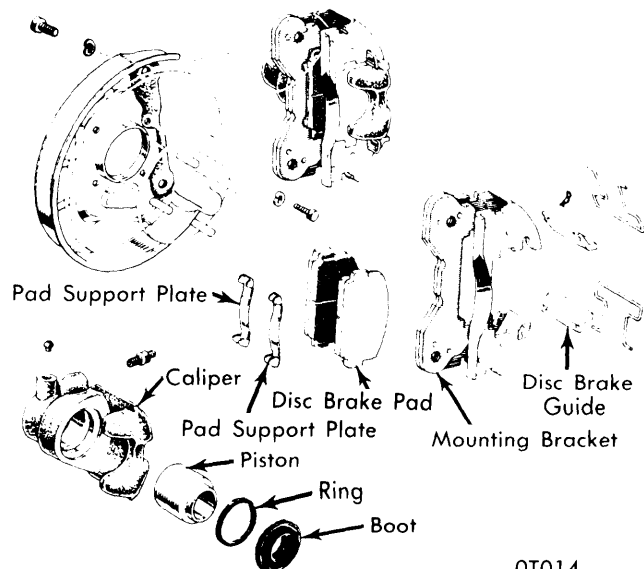

OT014

**SINGLE PISTON CALIPER ASSEMBLY**

## TOYOTA (Cont.)

**Removal (All Others)** — Raise and support vehicle, and remove front wheel. Remove hole pin retaining clips, then remove hole pins, springs, disc pads, and anti-squeal shims from vehicle.

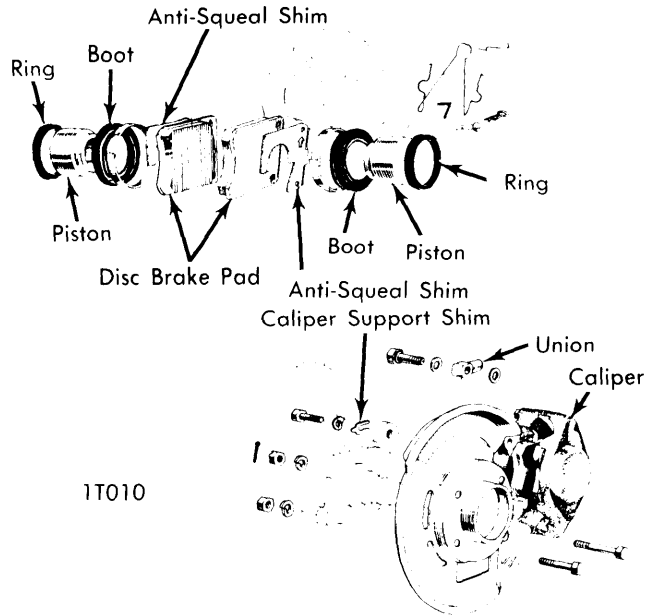

**DUAL PISTON CALIPER ASSEMBLY**

**Installation (All Models)** — To install disc pads, reverse removal procedure, making sure arrow on anti-squeal shim points toward forward rotational direction.

### FRONT DISC BRAKE CALIPER

**Removal (Celica ST)** — Raise and support vehicle, and remove wheel. Remove disc brake pads from vehicle. Disconnect hydraulic line at caliper and remove caliper mounting bracket. Remove caliper and support springs from vehicle as an assembly.

**Removal (All Others)** — Raise and support vehicle, and remove wheel. Disconnect hydraulic line at back of caliper. Remove caliper mounting bolts, noting number of shims on each bolt. Remove caliper and disc pads from vehicle as an assembly.

**Installation (All Models)** — To install, reverse removal procedure. *NOTE* — It may be necessary to push pistons back into caliper bores to install over rotor. Bleed hydraulic system.

### FRONT DISC BRAKE ROTOR

**Removal** — Prior to removal, measure and record rotor rotational runout. Raise and support vehicle, and remove wheel. Remove hub grease retainer, then remove cotter pin, claw washer, castle nut, and outer wheel bearing. Remove caliper assembly, and remove hub and rotor from vehicle as an assembly.

**Installation** — To install, pack wheel bearings with chassis grease, and reverse removal procedure.

### BRAKE DRUM

**Removal (Front)** — Raise and support vehicle, and remove wheel. Remove hub grease retainer, then remove cotter pin, castle nut, claw washer, and outer wheel bearing. Remove hub and brake drum from vehicle as an assembly.

**Removal (Rear)** — Raise and support vehicle, and remove wheel. Remove brake drum set screws, and pull drum from axle flange.

**Installation (All)** — To install, reverse removal procedure, ensuring all bearings are properly lubricated, and that all nuts and bolts are tight.

### BRAKE SHOES

**Removal (Front)** — Raise and support vehicle. Remove wheel and brake drum. Remove tension spring from shoes, and remove automatic adjuster lever, spring, and cable (if equipped). Remove shoe guide, remaining tension springs, shoe hold down pins and springs, and remove shoes from backing plate. Adjusting screw assembly will drop out when shoes are removed.

**Removal (Rear)** — Raise and support vehicle. Remove wheel and brake drum. Remove parking brake cable from lever, and remove tension springs from shoes. Remove self adjuster mechanism (if equipped). Remove shoe guide plate, shoe hold down pins and springs, and remove parking brake strut. Remove brake shoes from backing plate. Remove parking brake actuating lever, and self adjusting lever and latch from brake shoe.

**Installation (All)** — To install, reverse removal procedure, applying lubricant to friction points on backing plate, shoes, self adjusters, and parking brake levers.

### MASTER CYLINDER

**Removal** — Disconnect hydraulic lines at master cylinder, and disconnect pressure switch wiring. Loosen master cylinder reservoir mounting bolts, and remove master cylinder and mounting bracket from vehicle as an assembly.

**Installation** — To install, reverse removal procedure, and bleed hydraulic system.

### POWER BRAKE UNIT

**Removal & Installation** — Remove master cylinder assembly from vehicle. Disconnect push rod clevis at brake pedal. Remove power booster attaching hardware, and remove booster assembly from vehicle. To install, reverse removal procedure.

## OVERHAUL

*NOTE* — When overhauling caliper, wheel cylinder, or master cylinder assemblies, all rubber components should be replaced. If cylinder bores in any part are pitted, or scored more than light honing will repair, entire assembly should be replaced.

### FRONT DISC BRAKE CALIPER

**Disassembly** — Remove caliper assembly from vehicle, and remove disc pads from caliper. Remove retaining ring and dust boot from caliper piston. Position padding or a wooden block

## TOYOTA (Cont.)

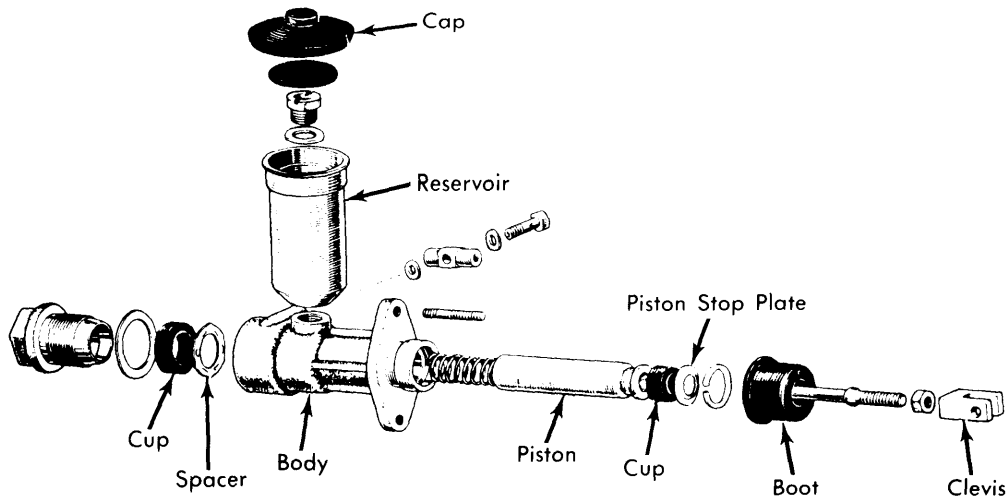

OT011

### SINGLE PISTON MASTER CYLINDER

in front of caliper piston to be removed, and carefully apply air pressure at fluid inlet fitting. On two piece pistons, apply compressed air at hole in center of piston insert to separate piston valves.

**Inspection** — Clean all parts with solvent, and blow dry with compressed air. Inspect caliper mounting or caliper for cracks, support springs for distortion, pad support plates or hole pins for warpage, pistons and cylinder bores for out-of-round, scoring, or corrosion, and check brake pads for thickness and eccentric wear.

**Reassembly** — Apply clean brake fluid to all metal parts, and rubber grease to piston seal and cylinder bore. Install piston seal into groove in cylinder bore. On two-piston calipers, install "O" ring on piston insert, and install insert in piston followed by spacer. Fit dust boot onto piston, and install

piston in cylinder bore. **NOTE** — Only finger pressure should be required to install piston into cylinder. Fit dust boot to cylinder, and install retaining ring.

### WHEEL CYLINDER

**NOTE** — Removal of wheel cylinder from backing plate is not necessary, except when replacement of cylinder assembly is required.

**Disassembly** — Remove adjuster lock spring and adjuster (if equipped). Remove bleeder screw. Remove cylinder boot(s), piston(s), cup(s), spring seat (if equipped), and spring.

**Inspection** — Clean all parts with solvent, and blow dry with compressed air. Check cylinder bore for out-of-round, corrosion, or scoring.

**Reassembly** — To reassemble, reverse disassembly procedure, using new rubber parts.

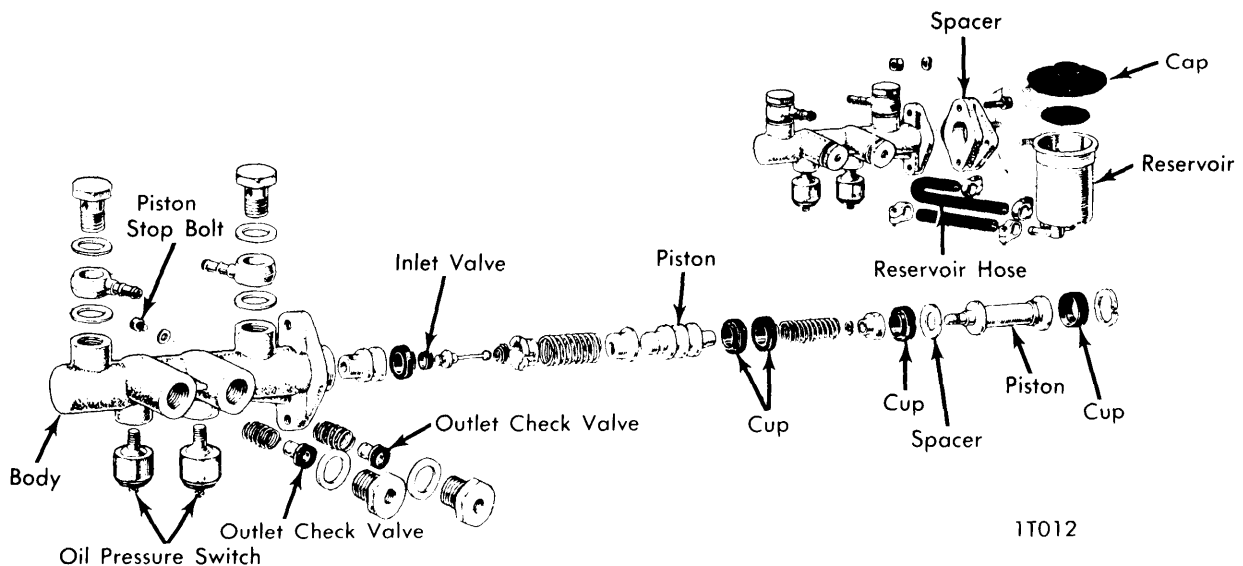

1T012

### DUAL PISTON MASTER CYLINDER

# Brakes

## TOYOTA (Cont.)

### MASTER CYLINDER

**Disassembly (Single Piston Cylinder)** – Remove reservoir from master cylinder. Remove snap ring and piston from end of cylinder bore. Remove outlet plug, check valve, and spring from outlet port of cylinder. Remove spring retainer from end of piston. Remove rod from retainer, and remove inlet valve. Remove piston cup from piston.

**Disassembly (Dual Piston Cylinder)** – Remove pressure switches, and clamp cylinder flange in a vise. Remove unions and bolts, outlet plugs, valves, and springs. Remove push rod boot. Remove snap ring from cylinder bore, then remove push rod and rear piston. Remove piston stop bolt from side of cylinder, and remove front piston. Remove inlet valve seat, and inlet valve. Disassemble pistons by removing springs, retainers, and cups.

**Inspection** – Clean all parts in solvent, and dry with compressed air. Check cylinder bore and pistons for out-of-round. Check all parts for pitting, scoring, or corrosion.

**Reassembly (All)** – To reassemble, reverse disassembly procedure, using new rubber parts and lubricating all parts with clean brake fluid prior to reassembly.

### TIGHTENING SPECIFICATIONS

Application	Ft. Lbs. (mkg)
<b>Caliper Mounting Bolts</b>	
Corona & Corona MK II .....	67-87 (9.3-12)
Celica .....	50-65 (7-9)
<b>Wheel Cylinder Mounting Bolts</b>	
Celica, Corona & Corona MK II .....	6-9 (.8-1.2)
All Others .....	7-12 (1.0-1.7)
Hydraulic Lines .....	9-13 (1.2-1.8)
Bleeder Screw .....	5-7 (.7-1.0)
Master Cylinder Mounting Bolts .....	7-12 (1.0-1.7)

### DISC BRAKE ROTOR SPECIFICATIONS

Application	Disc Diameter In. (mm)	Lateral Runout In. (mm)	Parallelism In. (mm)	Original Thickness In. (mm)	Minimum Refinish Thickness In. (mm)	Discard Thickness In. (mm)
Celica & Corolla	.....	.006 (.15)	.....	.394 (10)	.354 (9)	.....
Corona & Corona MK II	.....	.006 (.15)	.....	.492 (12.5)	.453 (11.5)	.....

### BRAKE DRUM SPECIFICATIONS

Application	Drum Diameter In. (mm)	Original Diameter In. (mm)	Maximum Refinish Diameter In. (mm)	Discard Diameter In. (mm)
Corolla	.....	.....	7.983 (202)	.....
Celica, Corona & Corona MK II	9.00 (228)	9.00 (228)	9.079 (230)	.....
Hi-Lux	10.00 (254)	10.00 (254)	10.1 (256)	.....
Land Cruiser	11.42 (290)	11.42 (290)	11.54 (293)	.....