

PEUGEOT

504

DESCRIPTION

Brake system is hydraulically operated, using a tandem master cylinder and a Bendix Mastervac power brake unit. Sedan models are equipped with Girling disc brakes, consisting of a brake rotor and dual piston floating caliper, on all four wheels. Station Wagons use Girling disc brakes on the front wheels and leading-trailing shoe/drum type brakes on the rear wheels. A load actuated compensator is used on all models to provide equal pressure distribution at front and rear brakes. Parking brake lever actuates rear wheel brakes through two cables.

ADJUSTMENT

DISC PADS

Disc brakes are self-adjusting, therefore no adjustment in service is required.

REAR BRAKE SHOES (STATION WAGON)

Raise and support rear of vehicle. To adjust, rotate front adjustment eccentric clockwise until wheel locks, then back off until wheel just turns freely. Repeat procedure for rear adjustment eccentric, but rotate the eccentric counterclockwise. *NOTE* — Do not alter the adjustment of brake pedal.

PARKING BRAKE

Sedan (Dashboard Mounted Handbrake) — With parking brake lever fully released, and rear control lever against nylon spacers, tighten adjusting nut until cup washer deflection is .04-.06" (1-1.5 mm). Tighten adjusting lock nut.

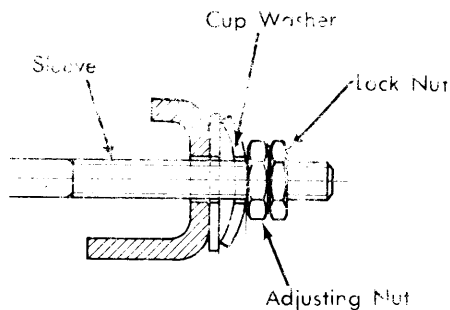

2PE01

ADJUSTING NUT & CUP WASHER CLEARANCE

Sedan (Handbrake Mounted Between Front Seats) — With parking brake lever fully released, loosen lock nuts on parking brake cables. Loosen adjusting nuts simultaneously until control lever almost touches nylon spacer, then tighten adjusting nuts ½ turn. Tighten lock nut and ensure rear wheels rotate freely with parking brake released.

Station Wagon — With parking brake lever fully released, loosen lock nut on parking brake cable. Tighten adjusting nut until parking brake is operational when lever is pulled 4 to 7 notches. Tighten lock nut and ensure rear wheels rotate freely with parking brake released.

BRAKE COMPENSATOR

NOTE — During compensator adjustment, spare tire should be in place, and fuel tank should be full.

Raise and support vehicle under frame. Place an 11 lb. (5 kg) weight on upper rear of compensator lever, and place a .05" (1.4 mm) feeler gauge between adjuster screw and compensator piston. *NOTE* — If reservoir is empty, use a .06" (1.6 mm) feeler gauge. Adjust screw to obtain a tight sliding fit with feeler gauge. Tighten lock nut, and remove weight.

HYDRAULIC SYSTEM BLEEDING

Attach a bleed tube to bleeder screw and immerse opposite end of tube in a container partially filled with brake fluid. Pump brake pedal two or three times, keep pedal fully depressed, open bleeder screw and exhaust air, close bleeder screw, and return brake pedal. Repeat operation until air bubbles are no longer seen in discharged fluid. Repeat procedure on remaining brake lines until air is bled from complete hydraulic system.

REMOVAL & INSTALLATION

DISC PADS

Removal — Raise and support vehicle under frame, and remove wheel to be serviced. Disconnect disc pad wear indicator electrical lead. Remove disc pad thrust spring, retaining fork mounting bolt, and retaining fork. Remove pad assembly from caliper.

Installation — To install, reverse removal procedure and note the following: Using a suitable tool press pistons to bottom of caliper bore before installing pads. Replace retaining fork and springs when fitting new pads.

REAR BRAKE SHOES

Raise and support rear of vehicle, remove wheel and brake drum. Disengage return springs and mounting assemblies. Separate parking braking linkage from shoe. Pull brake shoes from wheel cylinder and lift from backing plate. To install reverse removal procedure and adjust brakes.

BRAKE CALIPER

Removal — Raise and support vehicle under frame. Mark wheel and hub for reassembly reference, then remove wheel. Disconnect brake pad wear indicator lead, and remove hydraulic hose from caliper housing. Disconnect parking brake cable and housing on rear calipers. Remove caliper mounting bolts, and remove caliper assembly from vehicle.

Installation — To install, reverse removal procedure, making sure hub and wheel reference marks are aligned. Bleed hydraulic system.

BRAKE ROTOR

Inspection — Mount a dial indicator to wheel hub carrier such that indicator contact tip is .984" from outer edge of rotor. Rotate disc through at least one complete revolution, and note indicator reading. Maximum allowable deflection is .003".

Removal (Front) — Remove caliper mounting bolts, and support caliper out of way to prevent damage to brake hose. Remove wheel bearing adjusting nut and outer wheel bearing. Remove rotor assembly from vehicle. Hub and disc may now be separated by removing disc attaching bolts from rear of hub.

PEUGEOT (Cont.)

Removal (Rear - Exterior Mounted Rotor) - Remove flexible brake hose from bracket on rear control arm. Remove brake line from clamp on rear arm. Remove disc pads, then remove caliper assembly and support it out of the way. Remove rotor attaching nut, and remove rotor assembly from vehicle.

Removal (Rear - Interior Mounted Rotor) - Remove flexible brake hose from bracket on rear control arm. Remove brake line from clamp on rear arm. Remove disc pads, then remove caliper assembly and support it out of the way. Remove drive shaft. Disconnect control arm and support it out of the way. Remove hub carrier attaching nut and remove rotor assembly from vehicle. Hub and disc may now be separated.

Installation (All Models) - To install, reassemble hub and disc (if disassembled), and reverse removal procedure.

OVERHAUL

FRONT DISC BRAKE CALIPER

Disassembly - Clamp caliper assembly in a soft-jawed vise. Remove thrust spring, retaining fork bolt, retaining fork, and disc pads. Using suitable tool (8.0803 E), bottom piston in caliper bore. Remove caliper armature, and disengage armature from grooves in caliper housing. Remove spring clips securing piston protectors, and remove protectors. Force both pistons out of caliper bore. Remove nylon spacer from piston on armature side. Remove sealing rings from caliper bore. Clean pistons and caliper with denatured alcohol.

Reassembly - Lubricate new rubber parts with suitable lubricant prior to reassembly. Install sealing rings in caliper bore. Fit pistons in caliper bores, with piston groove inclined 1/8 turn from vertical. Install protectors with thin spring clip on rotor side. Position nylon spacer in piston, and install thrust plate. Install caliper armature, retaining fork, retaining fork bolt, and disc pads.

REAR DISC BRAKE CALIPER

Disassembly - Clamp caliper assembly in a soft-jawed vise. Remove thrust spring, retaining fork, and disc pads. Turn piston so that groove in piston is 1/8 turn from vertical toward disc pad guide. Remove thrust spring from armature, and remove armature from caliper housing. Remove parking brake return spring, then remove parking brake lever. Remove nylon spacer from piston, and remove piston protectors. Remove both pistons by pushing against grooved piston. Remove sealing rings from caliper bore, and clean pistons and caliper with denatured alcohol.

Reassembly - Lubricate new rubber parts with suitable lubricant prior to reassembly. Install sealing rings in caliper bores. Fit pistons into caliper bores, with piston groove inclined 1/8 turn from vertical. Install parking brake lever. Install protectors, with thin spring clip on rotor side. Raise parking brake lever, and install nylon spacer on piston. Install thrust plate, and install parking brake return spring. Install caliper armature, retaining fork, retaining fork bolt, and disc pads.

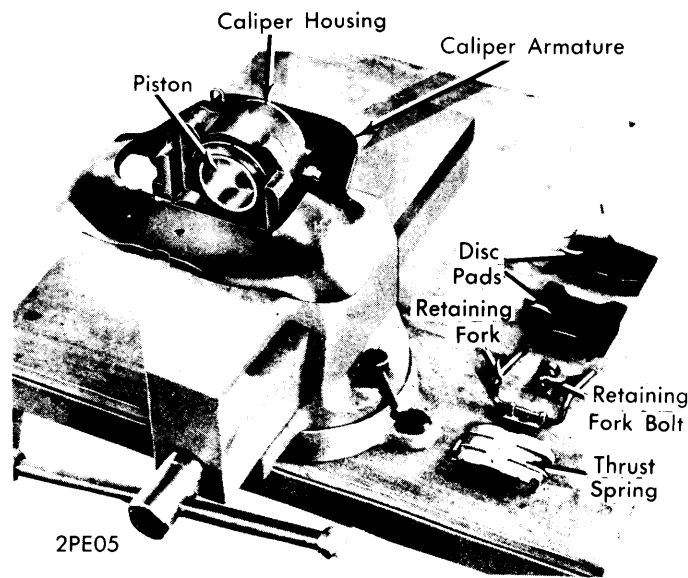

DISASSEMBLING CALIPER ASSEMBLY

TIGHTENING SPECIFICATIONS

Application	Ft. Lbs. (mkg)
Caliper Mounting Bolts	
Front	51 (7)
Rear	31 (4.3)
Retaining Fork Bolt	13 (1.8)
Rotor-to-Hub Bolts	34 (4.7)
Hub Carrier Nut	181 (25)
Wheel Stud Nut	43 (6)
Parking Brake Cable Bracket Bolt	7 (1)

DISC BRAKE ROTOR SPECIFICATIONS

Application	Disc Diameter In. (mm)	Lateral Runout In. (mm)	Parallelism In. (mm)	Original Thickness In. (mm)	Minimum Refinish Thickness In. (mm)	Discard Thickness In. (mm)
All Models						
Front	10.75 (273)	.003 (.07)	.0008 (.02)	.502 (12.75)	.443 (11.25)	.423 (10.75)
Rear (Sedan Only)	10.75 (273)	.003 (.07)	.0008 (.02)	.394 (10)	.354 (9)	.335 (8.5)

Brakes

PEUGEOT (Cont.)

BRAKE DRUM SPECIFICATIONS				
Application	Drum Diameter In. (mm)	Original Diameter In. (mm)	Maximum Refinish Diameter In. (mm)	Discard Diameter In. (mm)
Station Wagon (Rear)	11.024 (280)	11.024 (280)	11.063 (281)	11.083 (281.5)