

## LUV

## LUV

## DESCRIPTION

Brake system is hydraulically actuated, using a tandem master cylinder and a Master-Vac power brake unit. Front brakes are leading shoe type, actuated by two single piston wheel cylinders. Rear brakes are leading-trailing shoe type, actuated by a dual piston wheel cylinder. Parking brake is cable and lever operated, actuating shoes of rear brake assemblies.

## ADJUSTMENT

## PEDAL HEIGHT

Pedal height, measured from top of pedal pad to floor, should be 5.9-6.3". If adjustment is required, disconnect battery ground cable and stop lamp switch wiring harness. Remove stop lamp switch from bracket, then rotate master cylinder push rod until proper pedal height is obtained. Install stop lamp switch, then adjust clearance between switch housing (not actuating pin) and brake pedal tab to .02-.04". Tighten lock nuts and connect stop lamp switch wiring harness.

## BRAKE SHOES

Front and rear brake shoes are self-adjusting, therefore, no adjustment in service is required.

## PARKING BRAKE

Apply parking brake two notches from fully released position. Loosen equalizer check nut and adjust front jam nut until a light to moderate drag is felt when rear wheels are rotated forward. Tighten nuts securely, release parking brake lever, and ensure no drag is present.

## HYDRAULIC SYSTEM BLEEDING

Attach a bleed tube to wheel cylinder bleeder screw and immerse opposite end of tube in a container partially filled with brake fluid. Open bleeder screw  $\frac{3}{4}$  turn, depress pedal, close

bleeder screw before bottom of pedal stroke, and allow pedal to return slowly. Continue operation until no air bubbles are seen in discharged fluid. Bleed wheel cylinder closest to master cylinder first, then repeat procedure at remaining cylinders, ending with cylinder furthest from master cylinder.

## REMOVAL &amp; INSTALLATION

## BRAKE SHOES

**Removal (Front)** — Remove tire and wheel. Remove drum retaining screws and lift off drum. *NOTE* — Mark drum so reinstallation will be in original position. Disconnect wheel cylinder piston springs from pistons and shoes. Remove hold-down springs and retainers. Disconnect return springs and lift off brake shoes. Separate self-adjuster from brake shoe.

**Installation** — Install self-adjuster mechanism on brake shoes. *NOTE* — Ensure left and right side adjusters are in original position. Reposition return springs. Fit grooved portion of adjuster to guide pin and install brake shoes in position. Install piston springs. Install shoe hold-down springs and clips. Refit brake drum and adjust shoe to drum clearance. Install tire and wheel.

**Removal (Rear)** — Remove tire and wheel. Remove tension from parking brake cable, remove retaining screws and remove brake drum. *NOTE* — Mark drum for reassembly reference. Remove return springs, hold-down springs, and self-adjuster assembly. Separate primary and secondary brake shoes, adjuster mechanism, return spring, and parking brake strut. Separate parking brake lever and rear cable, and remove lever from secondary shoe.

**Installation** — Install parking brake lever to secondary shoe and rear cable to lever. Connect brake shoes together with return spring, and place adjuster screw into position, making

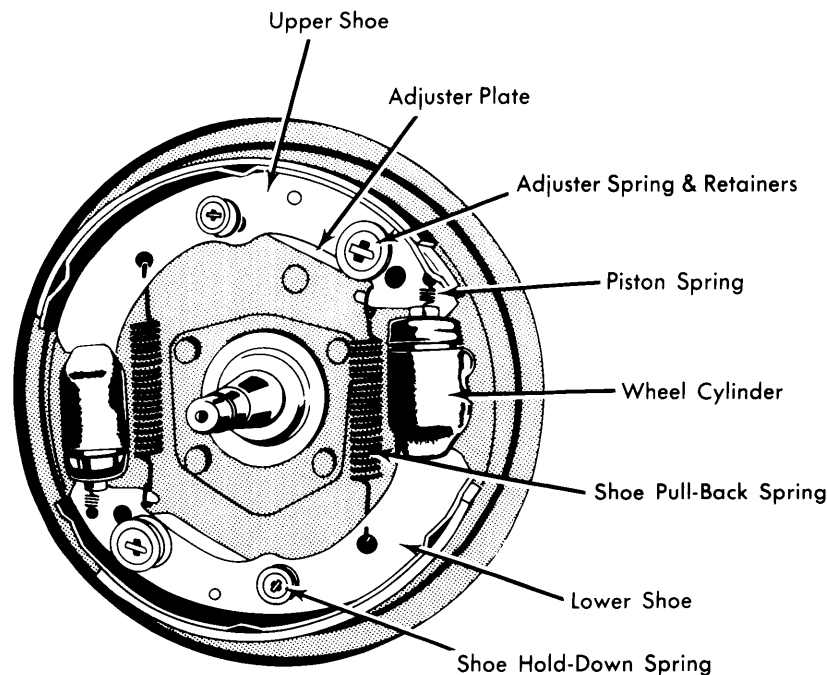

3LUA01

## FRONT BRAKE ASSEMBLY

## LUV (Cont.)

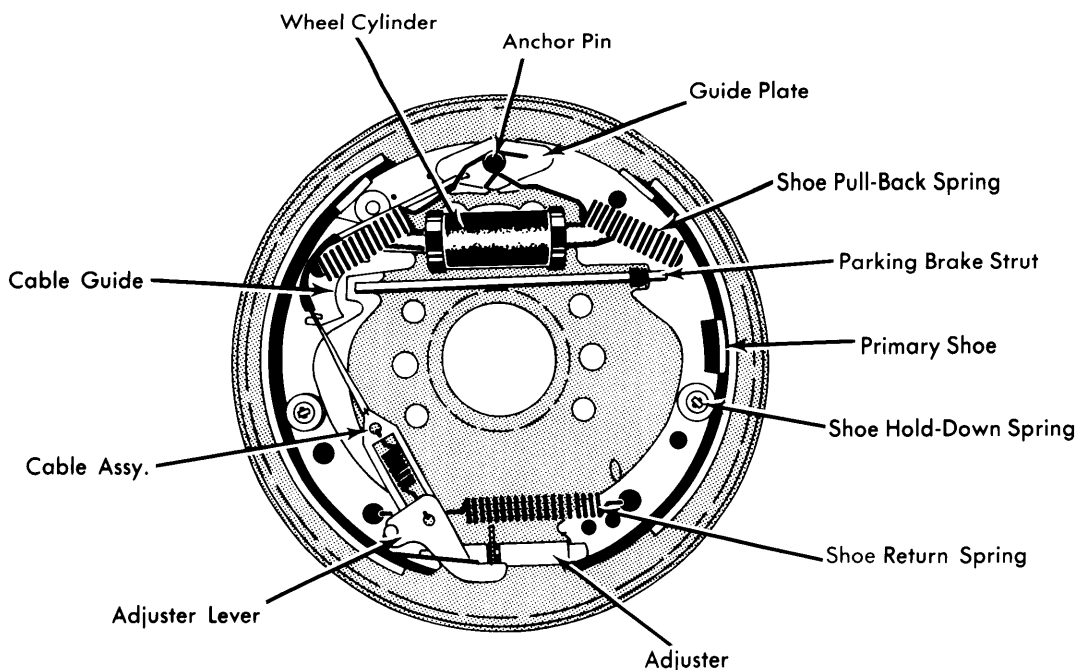

3LUA02

### REAR BRAKE ASSEMBLY

sure star wheel is nearest secondary shoe. Install parking brake strut with spring on primary shoe end, then fit shoes to wheel cylinder push rods. Install hold-down springs, self-adjuster assembly, and return springs.

#### WHEEL CYLINDER

**Removal** — With brake drum removed, disconnect brake shoe return springs. Disconnect hydraulic line and bolts retaining cylinder to backing plate. Disengage cylinder push rod(s) from brake shoe(s) and remove cylinder.

**Installation** — Reverse removal procedure and bleed hydraulic system.

#### MASTER CYLINDER

**Removal** — Disconnect battery ground cable. Disconnect hydraulic lines at master cylinder and cover ends to prevent entry of dirt. Remove bracket bolt at front end of cylinder, and nuts retaining cylinder to power unit, then remove master cylinder and gasket from power unit.

**Installation** — Reverse removal procedure, bleed hydraulic system and adjust pedal height if necessary.

#### POWER BRAKE UNIT

**Removal** — Disconnect battery ground cable. Disconnect hydraulic lines at master cylinder and cover ends to prevent entry of dirt. Remove bolts attaching bracket to master cylinder and fender and remove bracket. Disconnect vacuum line at power unit and place out of way. Disconnect brake pedal return spring and push rod. Remove nuts attaching power unit to firewall, and remove power unit and master cylinder as an assembly.

**Installation** — Reverse removal procedure, bleed hydraulic system, and adjust pedal height if necessary.

## OVERHAUL

### WHEEL CYLINDER

**Disassembly** — Remove boots from cylinder ends, and remove pistons and cups. If equipped, remove expander spring. **NOTE** — *Front wheel cylinder pistons and cups are serviced as an assembly.*

**Cleaning & Inspection** — Clean all parts in clean brake fluid. **NOTE** — *Do not use mineral based solvents.* Inspect cylinder bore and pistons for rust, corrosion, or other damage; replace parts or cylinder as necessary. Measure clearance between piston and cylinder bore; if clearance exceeds .006", replace wheel cylinder assembly.

**Reassembly (Front)** — Lubricate cylinder bore with brake fluid, but do not lubricate piston and seal before assembly. Install piston assembly into cylinder and press new boot onto cylinder. **NOTE** — *Do not lubricate boot prior to installation.*

**Reassembly (Rear)** — Lubricate cylinder bore with clean brake fluid. Install spring expander into bore, then install new cups with flat surfaces toward outside. Install new pistons into cylinder with flat surfaces toward inside. **NOTE** — *Do not lubricate pistons or cups before installation.* Press new boots onto cylinder.

### MASTER CYLINDER

**Disassembly** — Remove reservoir caps, plates and strainers and drain brake fluid. Place cylinder in a vise and remove reservoirs. Remove connector bolt, connector and gaskets from rear outlet, then withdraw end plug, gasket, check valve, return spring and spring seat. Remove check valve assembly from front outlet. Push in on primary piston, remove stop bolt

# Brakes

## LUV (Cont.)

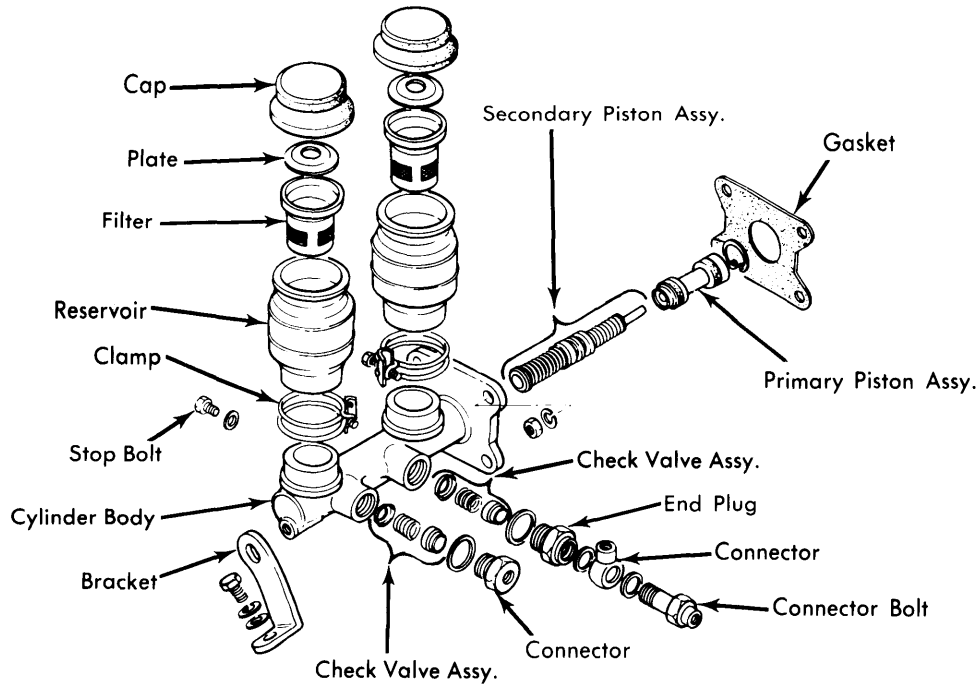

3LU03

### MASTER CYLINDER ASSEMBLY

and snap ring, and remove primary and secondary piston assemblies.

**Cleaning & Inspection** – Wash all parts in clean brake fluid and dry using compressed air. Blow out all passages, orifices and valve holes. If slight rust is found, polish clean with crocus cloth or emery paper. Inspect cylinder bore for scoring, pitting, or other damage. Check clearance between pistons and cylinder bore; if greater than .006", replace cylinder. *NOTE* – Manufacturer recommends replacing rubber parts whenever master cylinder has been disassembled.

**Reassembly** – Lubricate cylinder bore and all parts with clean brake fluid, reverse disassembly procedure, and note the following: Use all new gaskets and seals when reassembling. When reassembly is complete, bench bleed master cylinder as follows: Install plugs in all outlet ports of cylinder, fill reservoirs with clean brake fluid, and press in and out on primary piston until air bubbles are no longer seen in fluid.

### TIGHTENING SPECIFICATIONS

Application	Ft. Lbs. (mkg)
Backing Plate-to-Steering Knuckle	
Large Bolt .....	55 (7.7)
Small Bolt .....	35 (4.8)
Backing Plate-to-Axle Housing.....	55 (7.7)
Wheel Cylinder (Front)	
Large Bolt .....	40 (5.5)
Small Bolt .....	15 (2.0)
Wheel Cylinder (Rear – All) .....	10 (1.4)
Master Cylinder	
End Plug .....	90 (12.4)
Connector Bolt.....	45 (6.2)
Stopper Bolt.....	14 (1.9)
Bracket Bolts.....	10 (1.4)
Mounting Nuts.....	10 (1.4)
Power Brake Unit Mounting Nuts .....	10 (1.4)

### BRAKE SYSTEM SPECIFICATIONS

Application	Drum Diam. In. (mm)	Wheel Cylinder Diameter		Master Cylinder
		Front In. (mm)	Rear In. (mm)	Diameter In. (mm)
LUV	10 (254)	1.06 (26.9)	.75 (19.0)	.875 (22.2)

### BRAKE DRUM SPECIFICATIONS

Application	Drum Diameter In. (mm)	Original Diameter In. (mm)	Maximum Refinish Diameter In. (mm)	Discard Diameter In. (mm)
LUV	10 (254)	10.000 (254)	10.059 (255)	10.079 (256)