

## FIAT 128

128 Sedan  
128 Station Wagon  
128 Sport L

### DESCRIPTION

Brake system is hydraulically actuated, using a tandem master cylinder and a Master Vac power brake unit. Front wheel brakes are single piston sliding caliper type, while rear wheel brakes are leading-trailing shoe/drum type, using a duo-servo wheel cylinder. A brake pressure regulator is installed in rear hydraulic system to provide balanced braking. Parking brake is cable and lever actuated, acting on secondary shoes of rear brake assemblies.

### ADJUSTMENT

#### FRONT DISC BRAKE PADS

Front disc brakes are self-adjusting; therefore, no adjustment in service is required.

#### REAR BRAKE SHOES

Rear drum brakes are self-adjusting; therefore, no adjustment in service is required.

#### PARKING BRAKE

Depress brake pedal several times to position wheel cylinder pistons. With lever fully released, pull lever up three or four ratchet clicks. Loosen lock nut at tensioner and tighten adjusting nut until rear wheels are securely locked. Release parking brake lever and ensure that rear wheels are free to rotate.

#### PRESSURE REGULATOR

With pressure regulator mounting bolts loosened and link (4) disconnected from control arm anchor pin (5), check that the

axis of torsion bar end (3b) is  $2.126 \pm .197$ " from center of rubber buffer seat (2). Once obtained, position pressure regulator with piston (8) just in touch of torsion bar end (3a). Tighten regulator mounting bolts (7) on bracket (12), then connect link (4) to control arm anchor pin (5).

### HYDRAULIC SYSTEM BLEEDING

Attach a bleed tube to wheel cylinder bleeder screw and immerse opposite end of tube in a container partially filled with brake fluid. Loosen bleeder screw, depress brake pedal quickly and allow to return slowly. Continue operation until air bubbles are no longer seen in discharged fluid. Tighten bleeder screw on a down stroke of pedal. Repeat procedure on remaining brake lines until all air is bled from system.

### REMOVAL & INSTALLATION

#### FRONT DISC BRAKE CALIPER

**Removal** — Raise and support vehicle and remove front wheels. Plug outlet ports in master cylinder reservoir to prevent loss of fluid. Disconnect hydraulic line from caliper. Remove cotter pins from locking blocks, drive out locking blocks, and remove caliper, disc pads, and springs.

**Installation** — Reverse removal procedure, and bleed hydraulic system.

#### FRONT DISC BRAKE ROTOR

**Removal** — With caliper assembly removed, remove bolts securing caliper support bracket to steering knuckle and remove bracket. Remove bolts attaching rotor to wheel hub, then remove rotor using a suitable drift.

**Installation** — Install rotor onto wheel hub, install attaching bolts, and tighten evenly.

#### REAR BRAKE SHOES

**Removal** — Raise and support rear of vehicle and remove wheels. Remove bolts attaching drum to axle flange and remove drum. Install a suitable tool (A. 72236) to retain wheel cylinder pistons, remove upper and lower shoe return springs, shoe guide pins, springs and cups, then remove brake shoes.

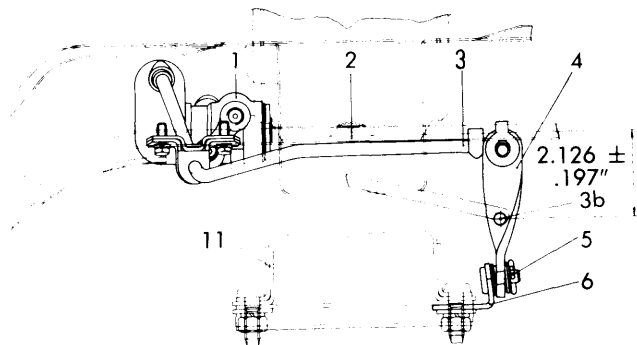
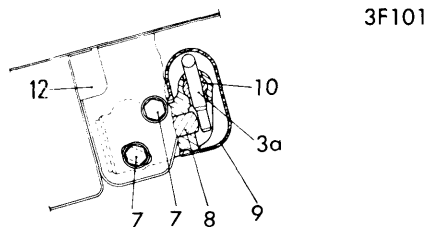

PRESSURE REGULATOR ADJUSTMENT

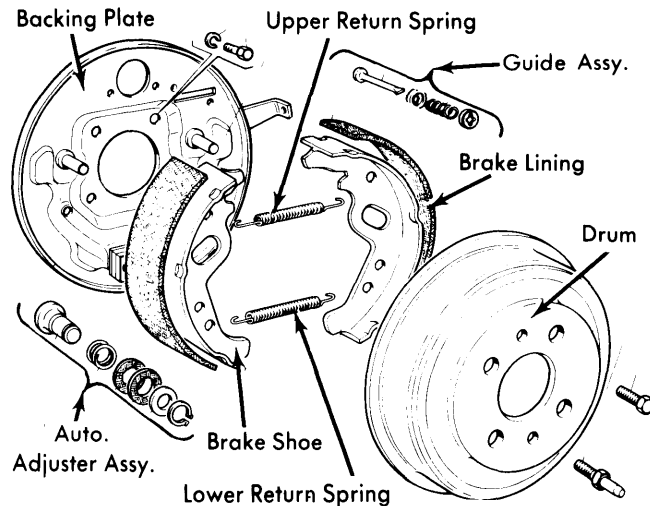

REAR BRAKE ASSEMBLY

3F102

## FIAT 128 (Cont.)

**Installation** — Reverse removal procedure making sure shoe ends are correctly positioned in wheel cylinder pistons.

**REAR WHEEL CYLINDER**

**Removal** — With rear brake shoes removed, disconnect hydraulic line from wheel cylinder, remove bolts attaching wheel cylinder to backing plate, and remove wheel cylinder assembly.

**Installation** — Reverse removal procedure and bleed hydraulic system.

**MASTER CYLINDER**

**Removal** — Remove reservoir cover and plug fluid outlet line to prevent loss of fluid. Remove spare tire. Disconnect fluid supply line at cylinder, hydraulic lines to front and rear brakes, and nuts and washers retaining master cylinder to power unit.

**Installation** — Reverse removal procedure and bleed hydraulic system.

**OVERHAUL****FRONT DISC BRAKE CALIPER**

**Disassembly** — Remove dust cap and, using compressed air applied to fluid inlet, remove piston from caliper bore. Remove piston seal from seat in caliper.

**Cleaning & Inspection** — Clean all parts in hot water and Fiat LDC detergent, blow dry with compressed air, and inspect for wear or damage. Replace damaged parts, do not attempt to refinish.

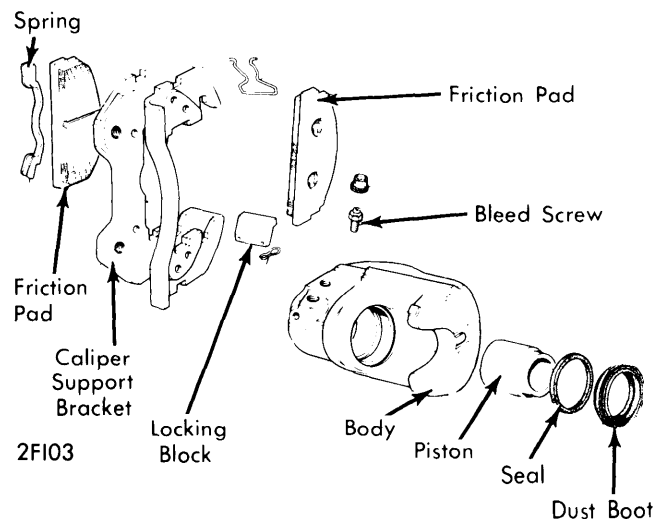
**FRONT CALIPER ASSEMBLY**

**Reassembly** — Install piston seal in groove in caliper, insert piston, and press to bottom of caliper bore. Install dust boot, making sure edge of boot is seated in groove of caliper body.

**REAR WHEEL CYLINDER**

**Disassembly** — Remove boots, then remove pistons, seal rings, backing washers and reaction spring. Remove bleeder screw.

**Cleaning & Inspection** — Clean and dry all parts and inspect for wear or damage. Light damage may be removed by honing; make sure bore size is not affected. *NOTE* — Manufacturer recommends replacing seal rings whenever wheel cylinder has been disassembled.

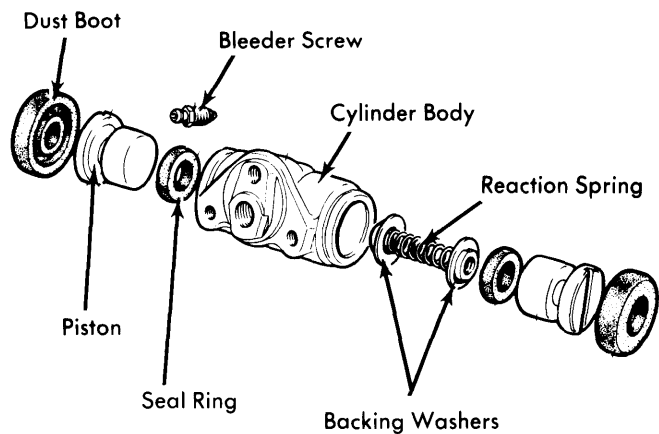

3FI04

**REAR WHEEL CYLINDER ASSEMBLY**

**Reassembly** — Reverse disassembly procedure and note the following: Coat all parts with brake fluid when assembling to prevent damage. When assembled, move pistons and make sure they slide freely in bore of cylinder.

**MASTER CYLINDER**

**Disassembly** — Disconnect fluid inlet line union from cylinder. Disengage boot from its position in cylinder body. Back out set screws and end plug. Remove the following parts: Piston return springs, cups, seal rings, and spacers.

**Cleaning & Inspection** — Clean and dry all parts and inspect for wear or damage. Light scoring may be removed by honing; make sure bore size is not affected. *NOTE* — Manufacturer recommends replacing seal rings whenever master cylinder has been disassembled.

**Reassembly** — Coat all parts in clean brake fluid and reverse disassembly procedure.

## FIAT 128 (Cont.)

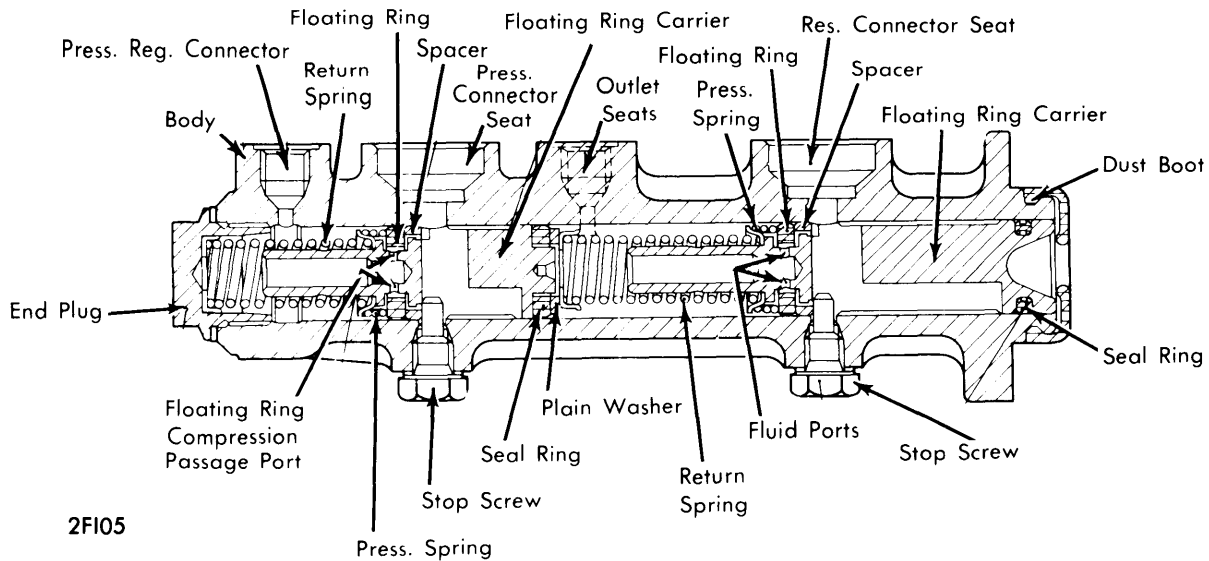

MASTER CYLINDER ASSEMBLY

BRAKE SYSTEM SPECIFICATIONS				
Application	Drum Diam. In. (mm)	Wheel Cylinder Diameter		Master Cylinder
		Front In. (mm)	Rear In. (mm)	Diameter In. (mm)
All Models	①	②	.750 (19.05)	.750 (19.05)

① — Front disc — 8.937" (227 mm); rear drum — 7.3" (185 mm).

② — Caliper bore diameter — 1.890" (48 mm).

DISC BRAKE ROTOR SPECIFICATIONS						
Application	Disc Diameter In. (mm)	Lateral Runout In. (mm)	Parallelism In. (mm)	Original Thickness In. (mm)	Minimum Refinish Thickness In. (mm)	Discard Thickness In. (mm)
All Models (Front)	8.937 (227)	.0059 (.15)	.0019 (.05)	.392-.400 (9.95-10.2)	.368 (9.4)	.354 (9)

BRAKE LINING SPECIFICATION							
Application	Drum Dia. In. (mm)	Width		Length		Thickness	
		Front In. (mm)	Rear In. (mm)	Primary In. (mm)	Secondary In. (mm)	Primary In. (mm)	Secondary In. (mm)
All Models	7.3 (185)	①	1.181 (30)	7.086 (180)	7.086 (180)	.165-.177 (4.2-4.5)	.059 (1.5)

① — Front disc brake equipped; min. pad thickness for Sedan & Station Wagon is .080" (2 mm) and for Sport L is .050" (1.5 mm).

# Brakes

## FIAT 128 (Cont.)

BRAKE DRUM SPECIFICATIONS				
Application	Drum Diameter In. (mm)	Original Diameter In. (mm)	Maximum Refinish Diameter In. (mm)	Discard Diameter In. (mm)
All Models (Rear)	7.3 (185)	7.293-7.304 (185.2-185.5)	7.325 (186)	7.355 (186.6)