

AUSTIN MARINA

Austin Marina

DESCRIPTION

Brake system is hydraulically operated, utilizing dual piston and pad front disc brakes and rear wheel drum brakes. Drum brakes are single piston, sliding cylinder type. A dual piston master cylinder is used in conjunction with a Supervac power unit. Parking brake is hand operated and cable/lever actuated, operating the sliding wheel cylinder.

ADJUSTMENT

FRONT DISC BRAKES

No adjustment is required.

REAR DRUM BRAKES

Raise rear of vehicle and block front wheels. Fully release parking brake and check that cables are not pulling on wheel cylinders. Turn adjuster screw in backing plate clockwise (viewed from center of vehicle) until brake drum cannot be turned. Loosen adjuster screw until wheel can just be turned.

PARKING BRAKE

With rear wheels properly adjusted, set parking brake lever on fourth ratchet tooth and check for braking effect on rear wheels. If braking effect is inadequate, loosen adjuster lock nut. Turn adjusting nut clockwise while holding cable sleeve from turning until correct adjustment is obtained. Tighten lock nut. Release parking brake lever and check that rear wheels rotate freely.

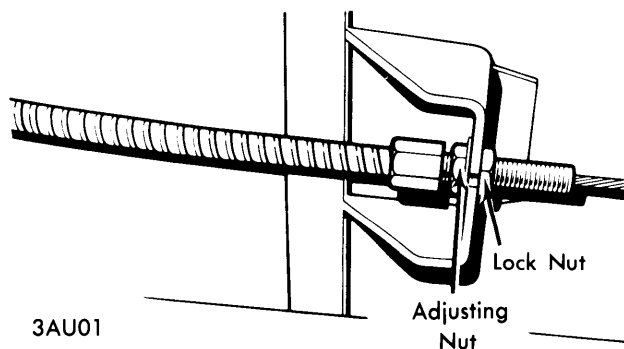

PARKING BRAKE ADJUSTMENT

HYDRAULIC SYSTEM BLEEDING

1) Ensure rear wheel cylinder is free to slide on backing plate. Make sure all hydraulic fittings are tight and that wheel cylinder bleeder screws are closed. Fill master cylinder reservoir with brake fluid and make sure level is maintained throughout bleeding operation.

2) Attach bleeder tubes to bleeder screws on left-front and left-rear brakes, noting that bleeder screw on left-rear brake controls bleeding of both rear brakes. Commence bleeding with light strokes of pedal. **NOTE** — Do not push pedal through its entire stroke. Do not test pedal until system is fully bled.

3) Bleed right-front brake after all air has been expelled from left side of vehicle. If warning light should be activated during bleeding operation, continue bleeding until all air has been expelled from system. Determine which brake caused light to be activated.

4) Attach a bleeder tube to a bleeder screw at opposite end of vehicle and open bleeder screw. Slowly depress pedal; as soon as light goes out, release pedal and tighten bleeder screw. Check fluid level in master cylinder reservoir and fill as necessary.

REMOVAL & INSTALLATION

FRONT DISC BRAKE PADS

Removal — Raise and support front of vehicle. Remove tire and wheel assembly. Remove spring clips and brake pad retaining pins. Remove brake pads and anti-squeal shims.

Installation — 1) Clean exposed end of piston and ensure that caliper is free of rust and dirt. Loosen bleeder screw and push pistons to base of cylinders. **CAUTION** — Level of fluid in master cylinder will rise. Siphon off sufficient fluid to prevent overflowing. Tighten caliper bleeder screw.

2) To complete installation, reverse removal procedure and note the following: Brake pads are interchangeable from side to side. Install anti-squeal shims with arrow pointing upwards, indicating forward direction of disc. With pads installed, pump brake pedal several times to reposition pistons. Bleed hydraulic system if necessary.

FRONT DISC BRAKE CALIPER

Removal — Raise and support front of vehicle. Remove tire and wheel assembly. Disconnect metal hydraulic line from flexible hose and from caliper. **NOTE** — Plug flexible hose to prevent loss of fluid. Remove caliper mounting bolts and remove caliper from vehicle.

Installation — To install, reverse removal procedure and note the following: Tighten caliper mounting bolts securely. Bleed hydraulic system.

FRONT DISC BRAKE ROTOR

Removal — Raise and support front of vehicle and remove tire and wheel assembly. Remove brake caliper. Remove grease cap, cotter pin, nut retainer, nut, and splined washer. Remove hub and rotor assembly. Remove four bolts retaining brake rotor to disc, and remove brake rotor.

Installation — 1) Install brake rotor onto hub, tightening retaining bolts securely. Install hub and rotor assembly onto axle and install bearing (if removed), splined washer, and nut. Spin hub and tighten nut to 5 ft. lbs. Loosen nut and then retighten finger tight.

2) Install nut retainer so that half of cotter pin hole is covered by one of the arms of retainer. Loosen nut and retainer until cotter pin hole is fully uncovered, install cotter pin, and lock by turning legs of pin around nut retainer.

3) **CAUTION** — Bearings must not be preloaded. Do not tighten nut so there is less than .001" free play, measured with a dial indicator. To complete installation, reverse removal procedure.

AUSTIN MARINA (Cont.)

REAR BRAKE DRUM

Removal & Installation — Raise and support rear of vehicle. Remove wheel and tire assembly. Remove two screws retaining drum to axle shaft flange. Loosen brake adjusting screw and remove brake drum. To install, reverse removal procedure and adjust brakes.

REAR BRAKE SHOES

Removal — With brake drum removed, disconnect cups and springs from anchor pins and remove pins. Disconnect return springs by lifting shoes from backing plate, disengaging front shoe from parking brake lever, and maneuvering shoes until spring tension is released.

Installation — Lightly coat shoe webs and anchor pins with Girling Brake Grease, taking care not to get any on shoe linings. Install return springs to shoes, engage parking brake lever into front shoe slotted web, and maneuver shoes into position on backing plate. Install anchor pins, springs and cups. Install drum and adjust brakes.

REAR BRAKE WHEEL CYLINDER

Removal — With brake drum and shoes removed, disconnect flexible brake hose from metal line, plug metal line to prevent loss of fluid, and disconnect flexible line from wheel cylinder. Disconnect parking brake cable clevis from parking brake lever. Remove dust plate, retaining plate and spring clip, and remove cylinder from backing plate.

Installation — To install, reverse removal procedure and bleed hydraulic system.

MASTER CYLINDER

Removal — Disconnect master cylinder hydraulic lines at pressure differential warning valve and at master cylinder. Plug cylinder outlet ports and valve inlet ports to prevent loss of fluid. Remove nuts retaining master cylinder to power unit, and remove master cylinder.

Installation — To install, reverse removal procedure, tighten mounting nuts securely, and bleed hydraulic system.

POWER UNIT

Removal — With master cylinder removed, remove vacuum hose at power unit. From inside vehicle, remove tray below instrument panel. Disconnect accelerator cable from pedal, remove nuts retaining pedal bracket, and remove accelerator pedal assembly. Remove clevis pin securing power unit operating rod to brake pedal, and remove nuts attaching power unit to mounting bracket. From engine compartment, remove power unit.

Installation — To install, reverse removal procedure, bleed hydraulic system, and note the following: Power unit operating rod must be retained to brake pedal lever with clevis pin installed in bottom hole of two holes in pedal lever.

PRESSURE DIFFERENTIAL WARNING VALVE

Removal — Disconnect battery and wiring to warning valve. Disconnect master cylinder-to-warning valve hydraulic lines, and disconnect warning valve-to-front and rear brake lines. Remove retaining bolts and remove warning valve.

Installation — To install, reverse removal procedure and bleed hydraulic system.

OVERHAUL

FRONT DISC BRAKE CALIPER

Disassembly — With caliper removed from vehicle, remove disc pads. Remove dust boot retaining rings and dust boots. Insert a piece of clean cloth between caliper pistons, then remove pistons by applying compressed air to fluid inlet port. Remove sealing rings from caliper. **CAUTION** — DO NOT separate caliper halves.

Inspection — Clean all parts in Girling Cleaning Fluid or alcohol. Examine piston and caliper for scoring, corrosion, or other wear; replace parts as necessary.

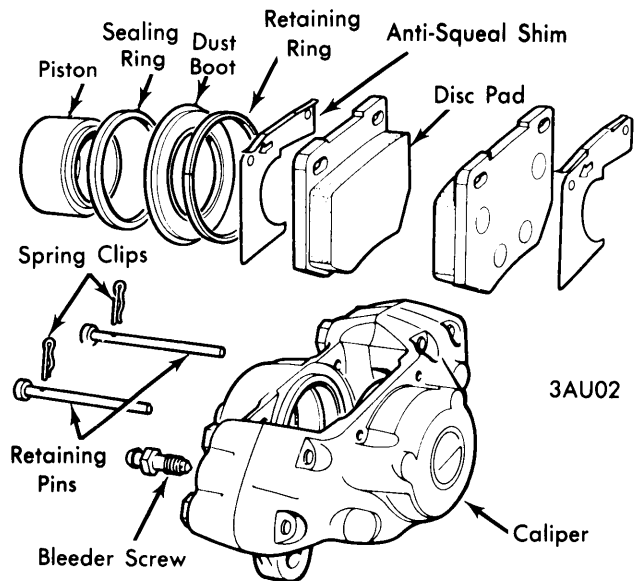

DISC BRAKE CALIPER ASSEMBLY

Reassembly — Lubricate all parts in clean brake fluid. Loosen bleeder screw. Install sealing rings inside caliper bores and press into seal grooves. Install dust boot on piston shoulder. Using a suitable tool (18G 590), press piston into caliper until .31" of piston is protruding. Install dust boot on cylinder shoulder and install retaining ring. Repeat procedure for remaining piston. Tighten bleeder screw and install brake pads.

REAR WHEEL CYLINDER

Disassembly — With cylinder removed from vehicle, remove rubber dust boot and withdraw piston and seal assembly. Remove seal from piston. Clean all parts in Girling Cleaning Fluid or alcohol and inspect for wear or damage; replace parts as necessary.

Reassembly — Lubricate all parts with clean brake fluid. Using fingers only, install new seal onto piston with lip of seal toward bottom of cylinder. Install piston and seal assembly into cylinder and install dust boot.

MASTER CYLINDER

Disassembly — 1) Remove screws retaining reservoir to cylinder body, then pivot reservoir to gain access to tipping valve. Remove valve securing nut and seal. Depress primary plunger and remove tipping valve. Apply air pressure to rear outlet port and remove all internal parts.

AUSTIN MARINA (Cont.)

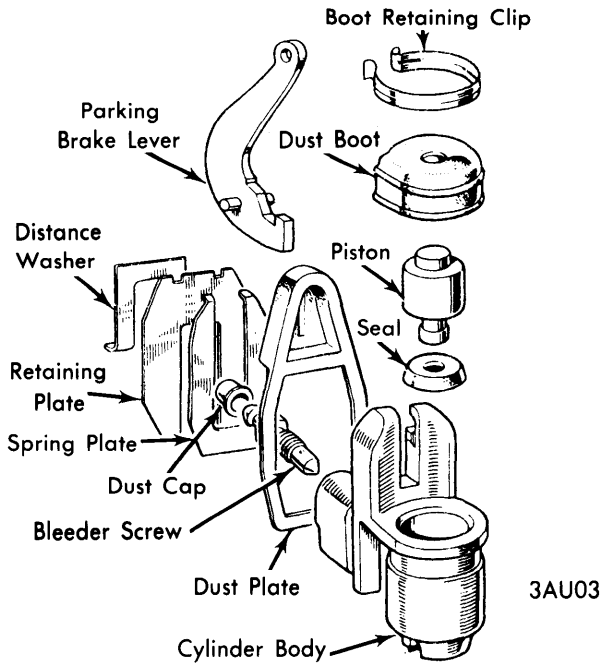

WHEEL CYLINDER ASSEMBLY

2) Separate plungers from intermediate spring. Lift retainer tang and remove secondary plunger from retainer. Compress spring and remove valve stem through elongated hole in retainer. Remove retainer from spring. Remove valve spacer and curved washer from valve stem, and remove valve seal from valve head.

Inspection — Clean all parts in Girling Cleaning Fluid or alcohol and dry thoroughly. Check master cylinder bore. If not

scored or ridged, new seals may be installed. If damaged, master cylinder must be replaced. Ensure that inlet and outlet ports are free of obstructions.

Reassembly — 1) Coat all parts in clean brake fluid and assemble when wet. Install valve seal with small diameter against valve head. Install curved washer with domed side against shoulder of valve stem (see illustration). Install valve spacer with legs toward curved washer.

2) Install spring on valve spacer and insert retainer in spring. Push end of retainer to compress spring against spacer, insert valve stem through elongated hole of retainer, and install valve stem into center of secondary plunger. Install seal on secondary plunger.

3) Insert small end of secondary plunger into spring retainer until leaf engages under shoulder of plunger. Install new seal on primary plunger with flat surface of seal against plunger. Install intermediate spring between primary and secondary plungers. Insert assembly into cylinder bore. Install tipping valve, securing nut, and reservoir.

POWER UNIT

NOTE — Manufacturer does not recommend overhaul of power brake unit. However, a service kit consisting of a check valve, front seal and plate assembly, and filter may be installed once unit has been removed from vehicle.

Disassembly — Pull back dust cover over push rod and remove end cap and filter. From front of power unit, remove seal and plate assembly from shell recess, and remove check valve and grommet.

Reassembly — Lubricate check valve grommet with Girling Grease and install into front shell. Install new check valve into grommet. Coat new seal and plate assembly with Girling Grease and install into front shell, making sure that plate faces inward. Install new filter into neck of diaphragm plate and install new end cap. Install new dust cover over lugs of rear shell.

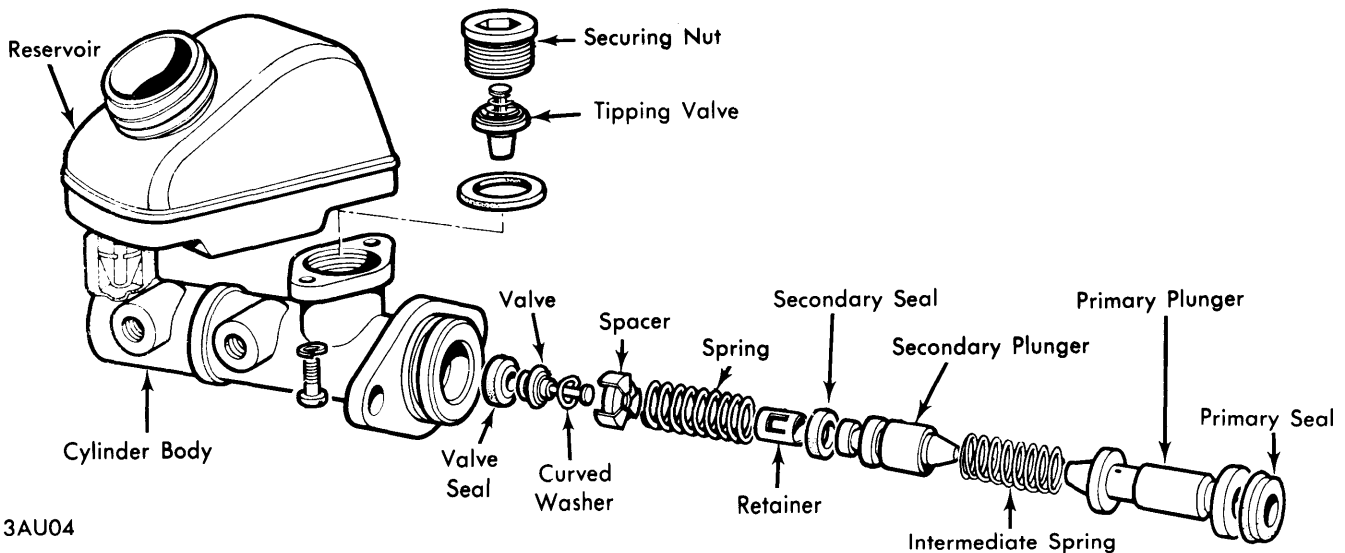

MASTER CYLINDER ASSEMBLY

AUSTIN MARINA (Cont.)

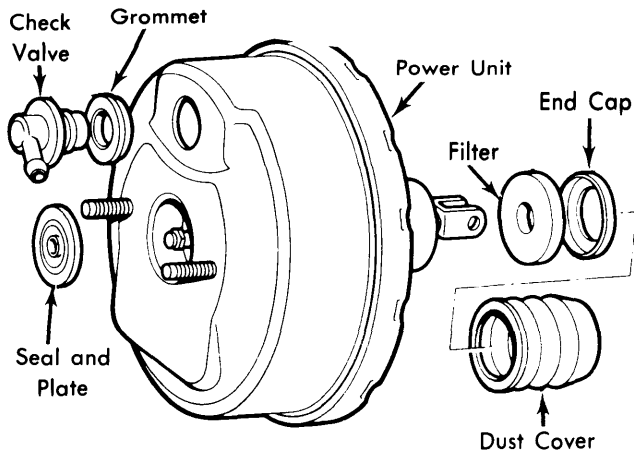

3AU05

SUPERVAC POWER UNIT

TIGHTENING SPECIFICATIONS

Application	Ft. Lbs. (mkg)
Brake Rotor-to-Hub.....	38-45 (5.3-6.2)
Caliper Mounting Bolts	50 (6.9)
Master Cylinder	
Cylinder-to-Power Unit	16-20 (2.2-2.7)
Tipping Valve Securing Nut	35-45 (4.8-6.2)
Wheel Cylinder	
Retaining Bolts	4-5 (.55-.69)
Bleeder Screw	4-6 (.55-.83)

BRAKE SPECIFICATIONS

Application	Measurement In. (mm)
Front Disc Rotor Diameter	9.785 (248.5)
Minimum Disc Pad Thickness063 (1.600)
Rear Drum Diameter	8 (203.2)
Rear Brake Shoe Thickness (New).....	.188 (4.78)

BRAKE SYSTEM SPECIFICATIONS

Application	Drum Diam. In. (mm)	Wheel Cylinder Diameter		Master Cylinder Diameter In. (mm)
		Front In. (mm)	Rear In. (mm)	
Austin Marina	8 (203.2)	①	.625 (15.86)	.750 (19.05)

① — Front disc equipped.