

MERCEDES-BENZ POWER-ASSISTED RECIRCULATING BALL

280
450SE
450SEL
450SL
450SLC

NOTE — Models 230 and 240D may have power steering as optional equipment. Power steering is standard equipment on all models listed above.

DESCRIPTION

Power steering is composed of power steering pump and steering gear. Power steering pump is engine driven vane type with control valve, which supplies fluid pressure to steering gear. Steering gear has integral piston/steering nut. Fluid pressure to each side of piston/steering nut is controlled by a control valve which is actuated by a lever from steering column shaft.

LUBRICATION

Capacity — 2.6 pts. (1.5 lts.) automatic transmission fluid.

REMOVAL & INSTALLATION

POWER STEERING PUMP

Removal — Remove power steering tank cover, spring and damping plate. Drain tank with a syringe. Disconnect and plug high pressure and return hoses. Loosen fastening bolts and push pump towards engine, remove "V" belts from pulley. Remove remaining bolts and remove pressure pump with carrier.

Installation — To install power steering pump, reverse removal procedure. Fill system with recommended fluid.

POWER STEERING GEAR

Removal — 1) Drain fluid from power steering pump. Disconnect and plug pressure line and return line from steering gear. Remove bolts from steering coupling. Remove rear exhaust system and left hand exhaust pipe at manifold (all 450 models). Disconnect center link and tie rod from pitman arm. Remove bolts securing steering gear to frame, force steering gear from steering column shaft, in a downward direction.

2) Drain fluid from steering gear, remove steering coupling and pitman arm from gear (be sure to mark pitman shaft-to-pitman arm position for proper assembly).

Installation — To install steering gear, reverse removal procedure. Replace locking nuts and bolts, tighten to specifications. Fill system with recommended fluid.

OVERHAUL

POWER STEERING PUMP

Disassembly — Remove knurled nut and tank cover with seal. Remove spring, damping plate and filter ring. Remove bolt and hollow screw, then remove tank with "O" rings from pump housing. Remove bolts connecting pump cover to pump body. Remove compression spring from pressure plate. Mark pressure plate and vane body and then lift off pressure plate from pins on vane body. Remove vane rotor with vanes and vane body (see illustration). Remove all "O" rings then remove control valve from pump body (see illustration). Dismantle control valve and check for worn, damaged or missing parts (see illustration).

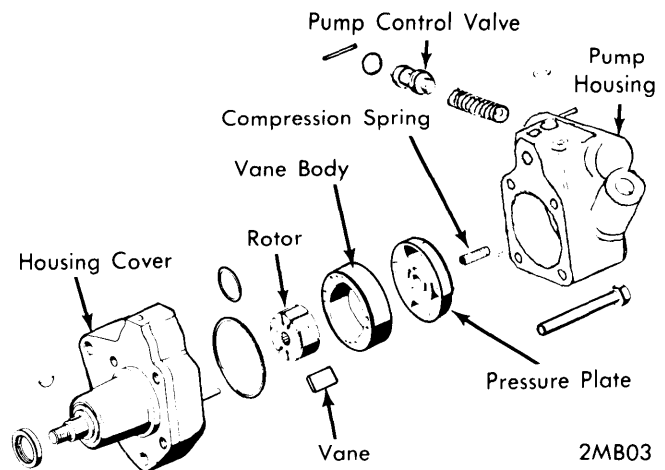

2MB03

POWER STEERING PUMP

Inspection — 1) Check vanes and rotor for damage or wear: vanes should slide easily in rotor. If necessary, replace vanes and rotor. Check vane body for excessive wear. If necessary to replace vane body, vanes and rotor must also be replaced. Check running surfaces of housing cover. If worn, replace entire pump. Check surface of pressure plate and replace if worn.

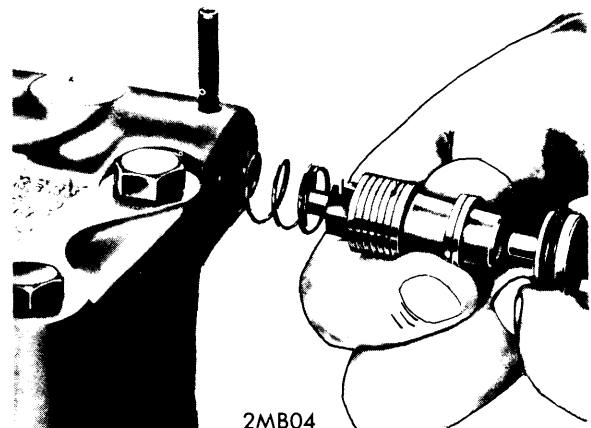

2MB04

PUMP CONTROL VALVE REMOVAL

MERCEDES-BENZ POWER-ASSISTED RECIRCULATING BALL (Cont.)

2) Check control valve. If worn, replace entire pump. Install shell halves on shaft and check end play. If end play exceeds specifications (see chart in this article), replace entire pump.

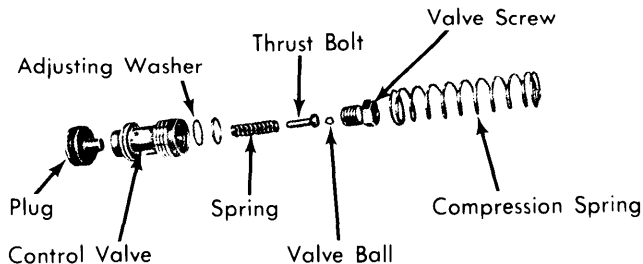

2MB05

CONTROL VALVE COMPONENTS

Assembly - To assemble steering pump, reverse disassembly procedure.

POWER STEERING GEAR

Disassembly - 1) Attach steering gear to a suitable assembly plate (116 589 01 59 00). Remove lock nut from adjusting screw and remove copper seal ring. Remove bolts attaching pitman shaft cover to steering case.

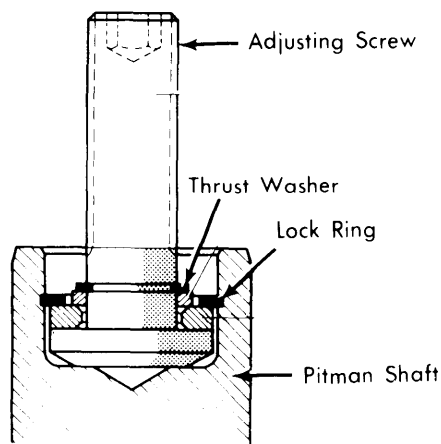

2MB06

ADJUSTING SCREW

2) With steering in center position, turn adjusting screw counterclockwise. This forces pitman shaft, with housing, from steering gear case. Remove pitman shaft with cover. Remove "O" rings from cover. Remove lock ring and seal ring. Remove lock ring from pitman shaft and remove adjusting screw with thrust washers (see illustration).

3) Remove bolts securing bearing cap to steering gear case. Turn worm gear counterclockwise until bearing cap is forced out of steering gear case. **NOTE** - Balls will fall out of ball guide if worm gear is turned too far. Remove bearing cap, worm gear with piston/steering nut from steering gear case. Unscrew worm gear with bearing cap from piston/steering nut. Do not lose balls.

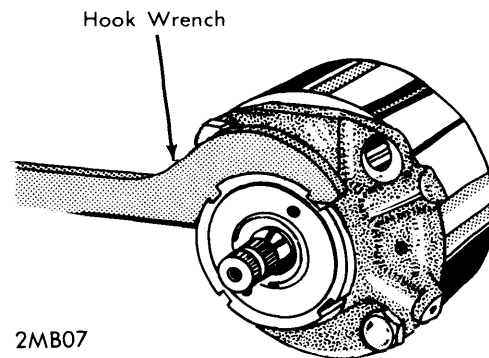

2MB07

HOOK WRENCH

4) Remove "O" ring from bearing cap and attach bearing cap to a suitable assembly fixture (116 589 03 59 00). Unscrew slotted nut, with hook wrench, from bearing insert and remove bearing insert from bearing cap, with spanner wrench (see illustrations). Remove seal and "O" rings from worm gear. Remove bearing and disc from bearing cap. Remove bolts, clamp and both ball guide halves from piston/steering nut.

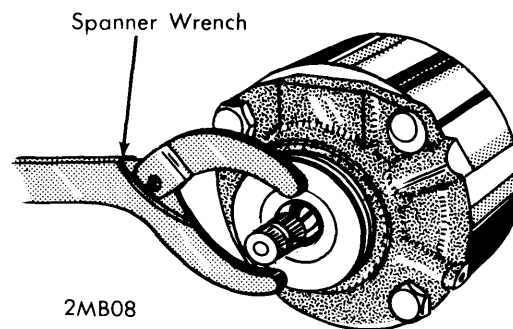

2MB08

SPANNER WRENCH

5) Using suitable clamp and tools (see illustration) remove worm gear nut from piston/steering nut. Remove seal ring and "O" ring from worm gear nut. On early models, remove axial

Open End Wrench
(116 589 00 09 00)

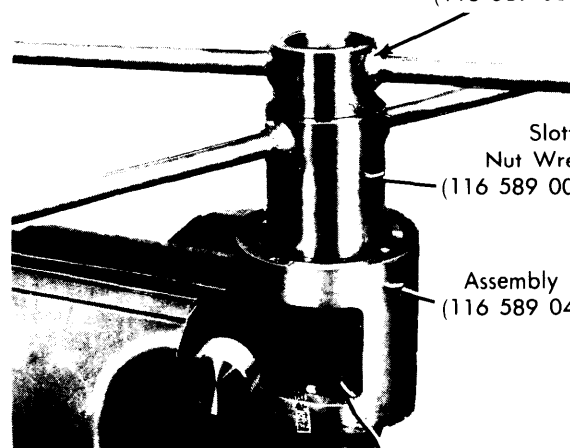

Slotted Nut Wrench
(116 589 00 07 00)

Assembly Fixture
(116 589 04 59 00)

Piston Steering Nut

2MB09

SPECIAL TOOLS

Power Steering

MERCEDES-BENZ POWER-ASSISTED RECIRCULATING BALL (Cont.)

disc from worm gear nut. Remove bearings from piston/steering nut (see illustration).

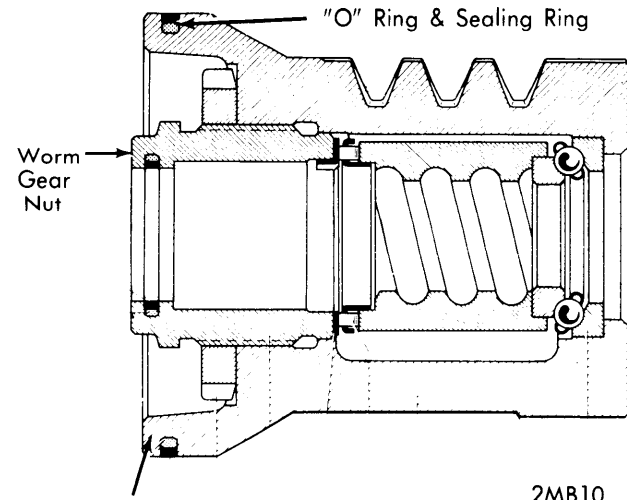

2MB10

PISTON/STEERING NUT

6) Remove lock ring, cover and control valve from steering gear case (see illustration).

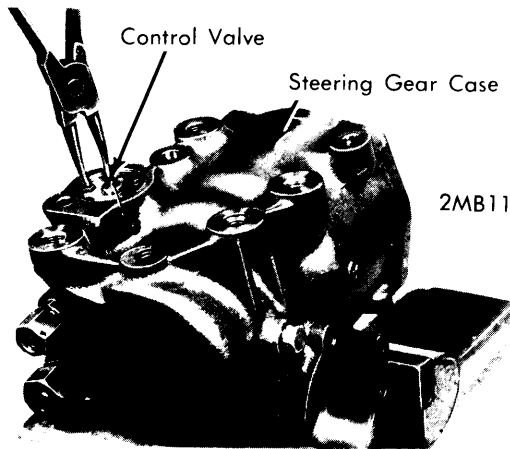

2MB11

STEERING GEAR CASE

Inspection - 1) On worm gear, check ball paths and bearings surfaces for wear and damage, replace if necessary.

2) Piston/steering nut, remove seal rings, "O" rings, bearings and races, and worm gear nut. Inspect for wear or damage and replace as necessary.

3) Check pitman shaft for wear or damage on bearing surfaces, check for bent or warped shaft and replace as necessary. Check steering case, cover, and bearing insert for wear or damage and replace as necessary.

4) On control valve, check reaction piston in control valve for free movement. If necessary remove supporting pistons from control valve by removing lock rings (see illustration).

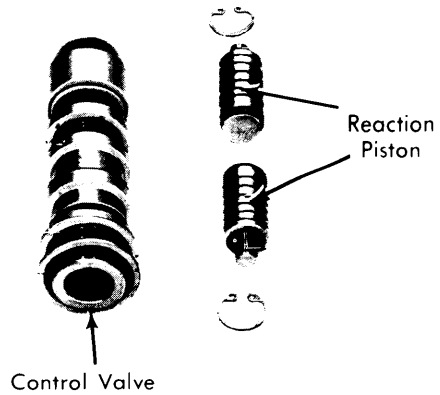

2MB12

CONTROL VALVE

Assembly - To assemble steering gear, reverse disassembly procedure. Replace all "O" rings and sealing rings. Adjust gear to specifications (see chart in this article).

Installation - Replace lock nuts and bolts. To install steering gear, reverse removal procedure and tighten to specifications. Fill system with recommended fluid.

SPECIFICATIONS

Steering Wheel Free Play	1" maximum
Power Steering Pump	
Circulation Pressure	28.4-71 psi
Pressure Relief Valve Opening Pressure	71 psi
Number of Balls in full Circuit	24
End Play of Pump Shaft - New	.028" maximum
Used	.039" maximum

TIGHTENING SPECIFICATIONS

Application	Ft. Lbs. (mkg)
Steering Gear-to-Frame	43 (6.0)
Pitman Arm-to-Pitman Shaft	116-145 (16.0-19.0)
Linkage Ball Pin Nuts	25 (3.5)
Slotted Nut-to-Bearing Cap	87-101 (12.0-14.0)
Bearing Cap-to-Steering Gear	43-47 (6.0-6.5)
Adjusting Screw Nut	22-25 (3.0-3.5)
Idler Arm-to-Frame	87 (12.0)
Pump Shaft Nut	43 (6.0)
Pump Housing Bolts	25-29 (3.5-4.0)