

RENAULT RACK & PINION

R-12
R-15
R-17

DESCRIPTION

Vehicles are fitted with a rack and pinion steering gear, which has direct steering linkage (tie rods) to each front wheel. Steering housing is mounted to front crossmember and connected to steering column through a flexible coupling.

ADJUSTMENT

STEERING GEAR HEIGHT (TOE-OUT)

Steering box is mounted on eccentrics (all models except R-12 with Auto. Trans.) or on shims (R-12 with Auto. Trans.). This mounting makes the relationship of the rack ends to the ball joints adjustable, such that the track variation between high and low positions tends toward a reduction of toe-out.

1) Place vehicle on lift, or alignment rack, with front wheels on radius gauges. Attach a brake press to pedal (to prevent rolling movement of wheels). Set steering at center point and lock in position with suitable holding tool (MS. 504) attached to steering wheel.

2) Compress front axle with suitable tool (T. Av. 238-02) until top of tool is $5\frac{5}{64}$ " (20 mm) below underside of lower member. Under vehicle, attach brackets of a suitable height measurement tool (T. Av. 246-01) such that the scale boards are $49\frac{3}{16}$ " (1.25 m) from center of front wheels (see illustration).

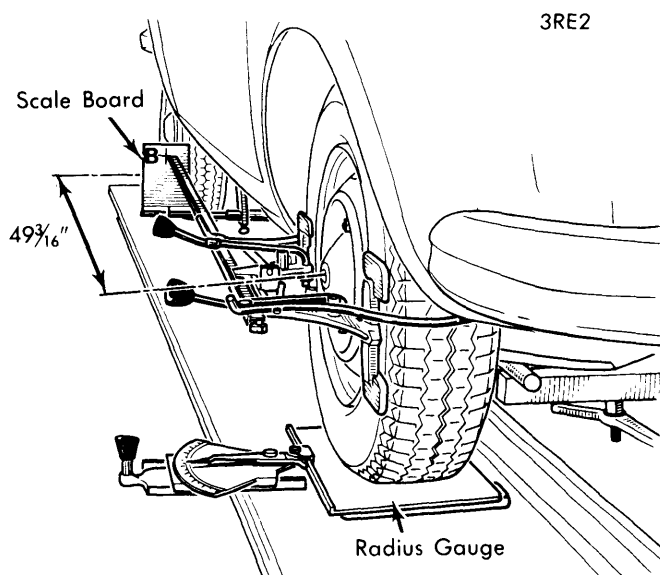

HEIGHT MEASUREMENT EQUIPMENT ATTACHED

3) Remove axle compression tool and raise vehicle slowly, with a jack (located in center of lower front crossmember). During this operation, the pointer of the measurement tool will have followed a curve from point "B" to one of the figures on scale "A" (see illustration). Read and record the nearest figure on scale boards on both sides of vehicle. Steering box height setting is correct if pointer is within "6-7.75" reading on the scale.

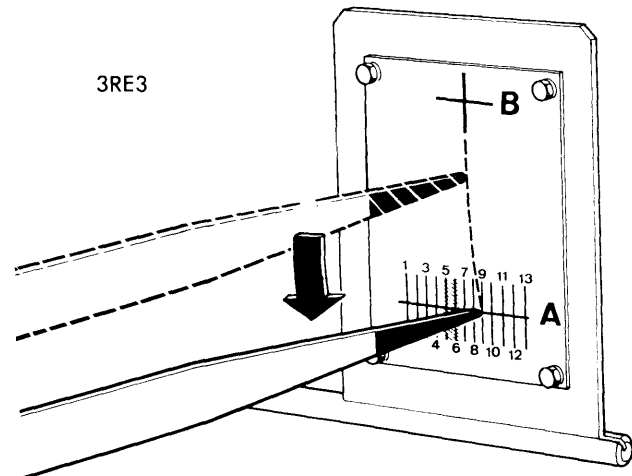

SCALE BOARD

4) To make adjustment on all Renault vehicles except R-12 with Auto. Trans., ensure pointer is still on "A" scale. Start with side farthest from correct setting. Remove battery and bracket. Unlock two top bolts holding steering box. Unlock eccentric washer on crossmember (leave other eccentric locked until it is to be turned). Turn eccentric until corresponding side pointer is in correct zone. Repeat at other eccentric. Tighten mounting bolts, recheck both settings, and, if correct, lock eccentrics.

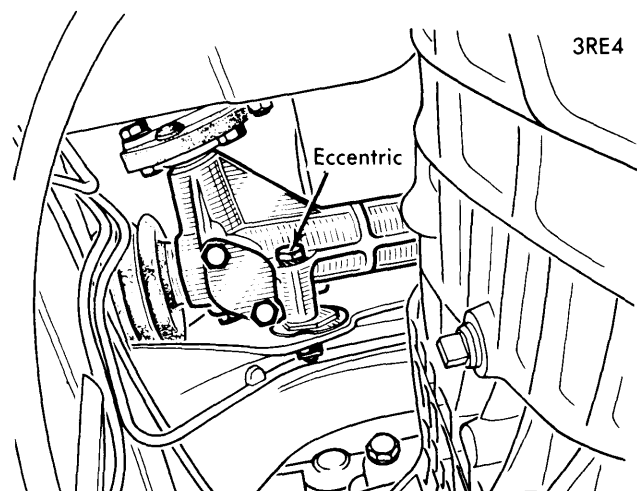

STEERING BOX ADJUSTMENT ECCENTRIC

Steering Gears & Linkage

RENAULT RACK & PINION (Cont.)

5) On R-12 with Auto. Trans., an adjusting shim is inserted between each mounting boss and steering box. Lower slot of each shim varies, depending upon height setting desired. Using a shim with greatest distance between top mounting hole and lower mounting slot will give steering box its lowest setting (see illustration).

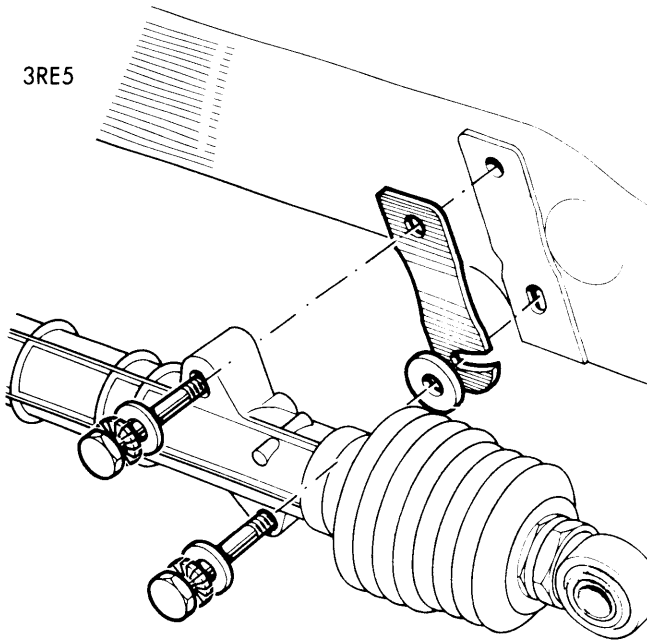

LOCATION OF MOUNTING SHIMS

6) To replace, add, or subtract shims, remove battery and its bracket. Unlock four steering box securing bolts. **NOTE** — Only remove top securing bolts. Swing out shim at bottom, then remove top bolt and shim (if necessary). Determine proper new shim and position on mounting boss. Insert and tighten all mounting bolts. Recheck setting.

SETTING STEERING CENTER POINT

To find center steering point, set center of rivet head on flexible coupling in line with index mark on pinion housing. This should give a setting of 2⁹/₁₆" (65 mm) on rack as shown in illustration.

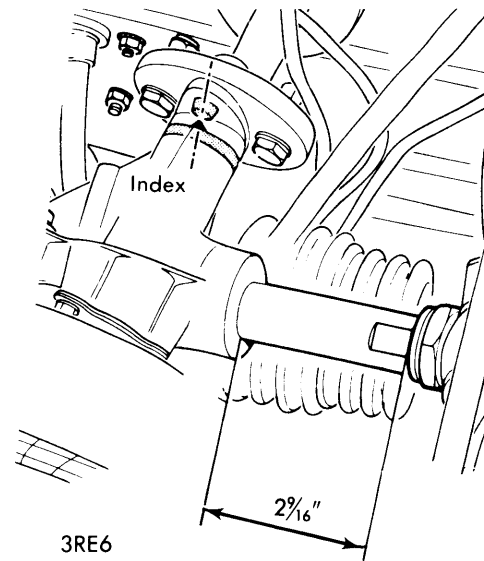

SETTING CENTER POINT

REMOVAL & INSTALLATION

Removal — Remove battery and its hold-down. Unscrew bolts attaching flexible coupling. Disconnect tie rods from rack ends (at eyebolts). Unscrew four bolts securing steering box to crossmember. **NOTE** — If steering box is not being exchanged for another, do not disturb eccentric lock tabs; this will retain original steering box height setting.

Installation — To install, reverse removal procedure, noting the following: Coat tie rod connections with suitable grease. Check condition of rack bellows and clamps. Align tie rod connecting bolts horizontally. After steering box is installed, carry out check of steering box height setting and wheel alignment.

TIGHTENING SPECIFICATIONS

Application	Ft. Lbs. (mkg)
Steering Box-to-Crossmember	25 (3.5)
Ball Joint Nuts	25 (3.5)
Flexible Coupling Nuts	10 (1.4)
Tie Rod Hinge-to-Rack Nuts	25 (3.5)
Steering Wheel Nut	35 (4.8)
Universal Joint Pin Nut	25 (3.5)