

AUSTIN MARINA RACK & PINION

Austin Marina

REMOVAL & INSTALLATION

STEERING RACK

Removal — 1) Remove lower instrument panel section, then instrument panel. Disconnect column switches at harnesses. Detach upper and lower column support brackets. Remove pinch bolt and nut retaining lower portion of steering column to steering rack pinion shaft. Lift out column assembly. Remove heater drain tubes.

2) Raise and support front of car. Remove retaining nuts from both tie rod ends. Using suitable tool (18G 1063), disconnect tie rod ends from steering levers. Remove nuts and washers retaining each rack clamp bracket to front support. Note relative position of packing strips to body panel; remove strips. Remove clamp brackets and rubber insulators. Withdraw rack assembly through wheel well. Remove pinion seal.

Installation — To install, reverse removal procedure, tightening nuts and bolts as required. Reset front wheel alignment. See *Austin Marina* in **WHEEL ALIGNMENT** Section.

3A502

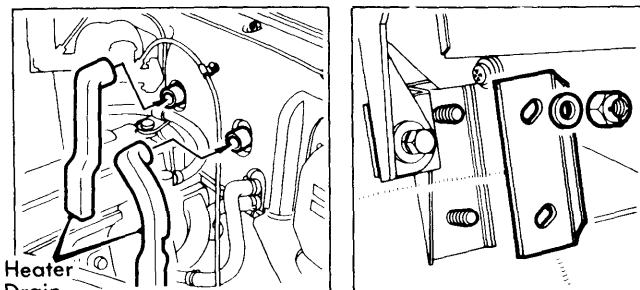

Heater
Drain
Tubes

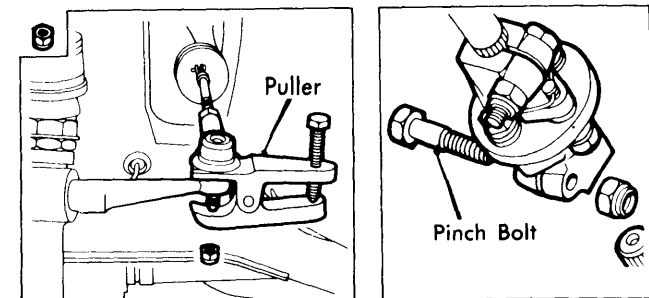
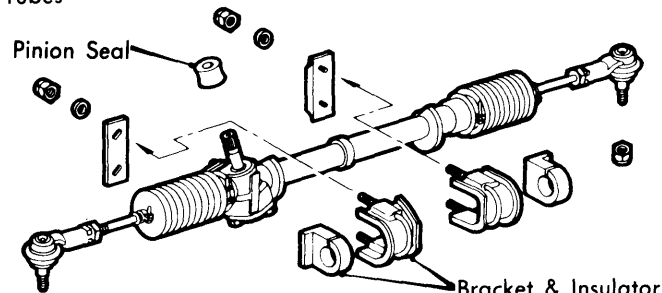

STEERING RACK REMOVAL

OVERHAUL

RACK & PINION ASSEMBLY

Disassembly — 1) Remove steering rack assembly, as previously outlined. Slacken tie rod end lock nuts, remove tie rod ends, then remove lock nuts. Remove rack seal clips and bellowed seals.

2) Pry out lock nut indentation from each ball housing. Using suitable tools (18G 706 and 18G 707), retain lock nut and unscrew ball housing from each end of rack; then, extract tie rod.

3) Remove ball cup and thrust spring from each end of rack. Pry out lock nut indentation from rack and remove lock nuts. Remove rack bearing pan-head screw. Withdraw bearing from rack housing.

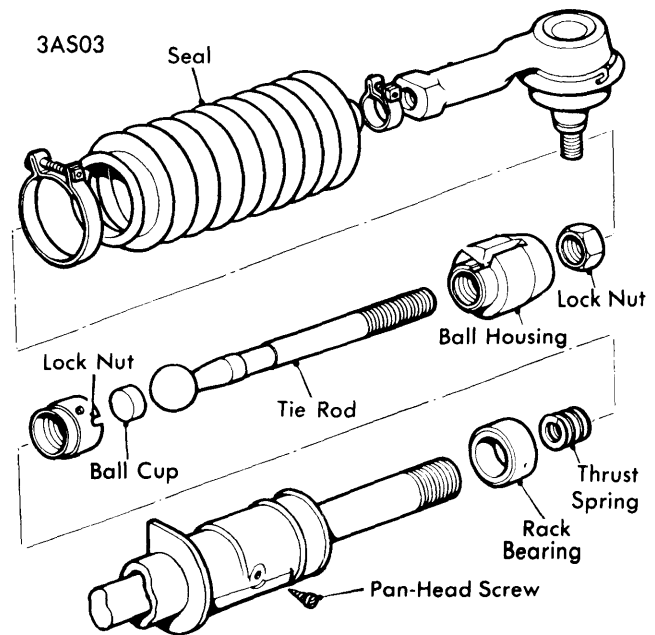

RACK DISASSEMBLY

4) Remove bolts and washers retaining rack yoke cover plate, then remove plate, shims, and joint washer. Extract rack support yoke and remove "O" ring and thrust washer from yoke.

3A504

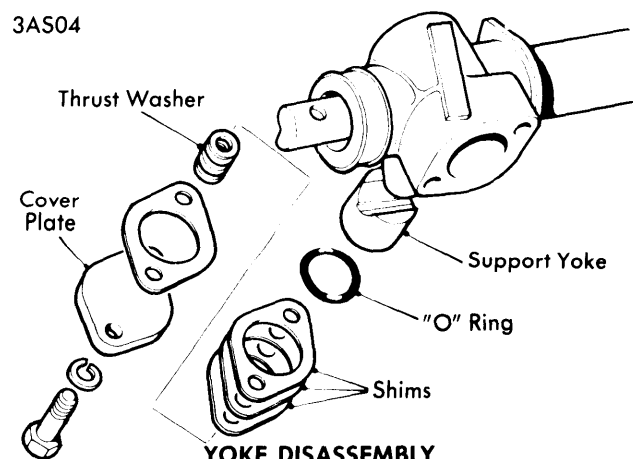

YOKE DISASSEMBLY

Steering Gears & Linkage

AUSTIN MARINA RACK & PINION (Cont.)

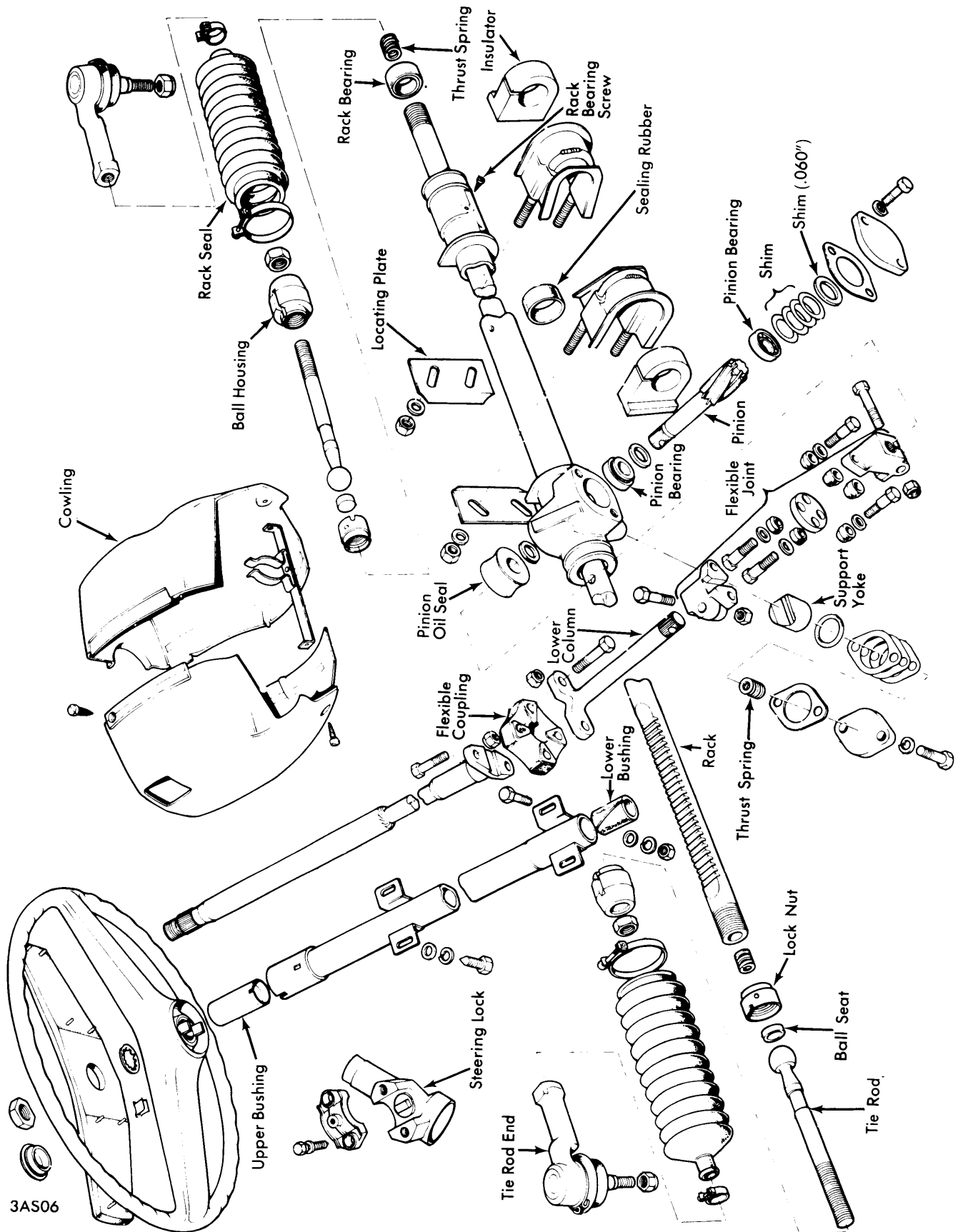

AUSTIN MARINA RACK & PINION ASSEMBLY

AUSTIN MARINA RACK & PINION (Cont.)

5) Detach and remove pinion end cover plate, shims, and joint washer. Push out pinion and lower bearing. Withdraw steering rack from rack housing. Remove upper pinion bearing and washer. Extract pinion shaft oil seal.

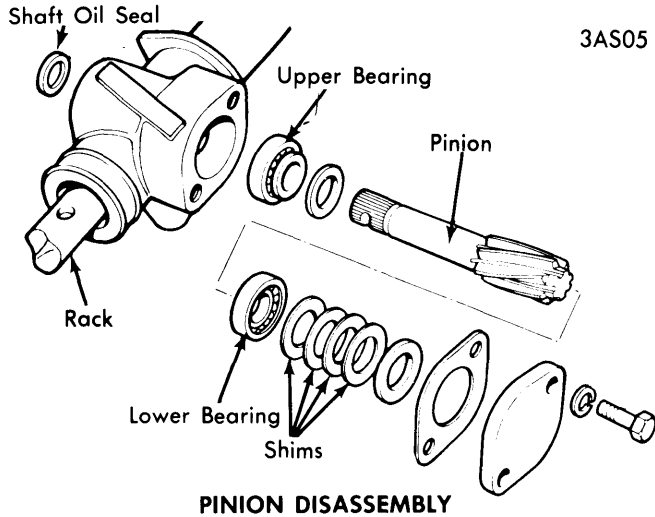

Inspection — Thoroughly clean all components. Inspect rack and pinion for wear, cracks, or damage. Check rubber seals for cracks, splits, or deterioration. Replace all worn parts.

Reassembly & Adjustments — 1) Fit new rack bearing into housing, with flats of bearing positioned offset to bearing retaining screw hole. Using a .119" (3 mm) drill, bore into bearing race. Remove all metal particles from bearing and housing. Coat bearing retaining screw with sealer and screw into race; ensure screw does not penetrate bore of bearing.

2) Position pinion washer to pinion. Install upper bearing on pinion, with thrust face to pinion washer. Reposition rack in housing. Insert pinion, centralize rack, and insert peg in center locating hole. When positioning pinion, ensure groove in serrations is facing and parallel with rack teeth.

3) Install lower bearing with thrust face toward pinion. Insert bearing shims until shim pack stands above pinion housing. Install pinion housing end cover without a gasket and hand-tighten bolts.

4) Measure gap between pinion housing and end cover. Record the measurement. Remove end cover. Adjust shim pack to obtain a .011-.013" (.28-.33 mm) gap. Ensuring that .060" (1.524 mm) shim is nearest the joint washer, install the corrected shim pack, joint washer, and end cover. Coat bolt threads with sealer and tighten as required. Install new pinion shaft oil seal.

5) Position damper yoke, cover plate, and gasket. Install cover bolts and washers, and tighten progressively while turning pinion back and forth (180° turns) until it is just possible to rotate pinion with preload gauge (18G 207) set at 15 Inch lbs.

6) Measure clearance between cover and housing. Record clearance. Remove cover and reassemble yoke damper components: Install damper spring, new "O" ring, and shims to recorded measurement PLUS .002-.055" (.05-.13 mm).

7) Tighten yoke cover bolts sufficiently. Check torque load required to start movement of pinion, using suitable gauge assembly (18G 207 and 18G 207A). Torque must not exceed 15 Inch lbs.

8) Screw new ball housing lock nut (as far as possible) onto each end of rack. Replace both thrust springs in rack ends. Insert each tie rod into ball housings and position ball cup against the thrust spring.

9) Tighten ball housing until tie rod is pinched. Screw lock nut to ball housing, using suitable tools (18G 705 and 18G 707). Check that tie rod is still pinched. Slacken ball housing back one-eighth turn to allow full articulation of tie rods.

10) Tighten locking ring (to housing) to specification. Check preload on tie rod ball spheres: should require 32-52 Inch lbs. to produce movement of tie rods. Punch ball housing edge of locking ring into locking slots of ball housing and opposite edge into rack locking slot.

11) Replace two rack bellowed seals and secure with clips. Position tie rod lock nuts and screw on each tie rod end an equal amount, until ball pin center measurement is 43.7" (110.9 cm). Sufficiently tighten lock nuts.

12) Add one-third pint (0.4 U.S. pt., 0.19 litre) of suitable lubricant through pinion seal, then locate and tighten small seal clip.

TIGHTENING SPECIFICATIONS

Application	Ft. Lbs. (mkg)
Rack Clamp Nuts	20-22 (2.8-3.0)
Tie Rod Ball Pin Nuts	20-24 (2.8-3.3)
Lower Flex Joint Pinch Bolt	6-8 (0.8-1.1)
Pinion End Cover Bolts	12-15 (1.7-2.1)
Yoke Cover Bolts	12-15 (1.7-2.1)
Locking Ring-to-Housing	33-37 (4.6-5.1)