

## VOLVO

140 Series  
164

## DESCRIPTION

Steering column is divided in two sections. Upper and lower sections are joined by means of a flange. A heavy frontal impact would cause flange to break from upper column. The upper portion of steering column would retain its position, eliminating possibility of its being forced toward driver. Upper part of column is carried in two ball bearings located in jacket tube. Lower end of steering column is connected to steering shaft by a flange.

## REMOVAL &amp; INSTALLATION

**Removal** — 1) Disconnect battery. Remove steering wheel as previously described: See *Volvo* under **STEERING WHEEL & COLUMN SWITCHES** in this section. Unscrew casing from around steering column. Release instrument cluster bracket and allow it to drop toward column. Remove cluster mounting screws and disconnect speedometer cable. Hold backside of instrument cluster while pushing up and in from front, until snap lock releases. Detach all connections from back of cluster and remove cluster from instrument panel.

2) Remove contact piece from back of ignition switch/steering lock. Drill and remove lock mounting shear bolts at column mounting bracket. Remove attaching bolts from mounting plate and take off left impact guard with slide piece (see illustration). Screw out bolt from under slide piece and unhook attaching plate. Turn back lock pin and lift out steering lock.

3) Remove turn signal assembly. Unscrew nuts at coupling between upper and lower steering shafts. Remove nut and clamp for lower column attachment. Withdraw both upper and lower steering shafts complete.

**Installation** — To install, reverse removal procedure, noting the following: When installing new shear bolts for column lock, do not break off heads until lock mechanism is completely assembled and installed.

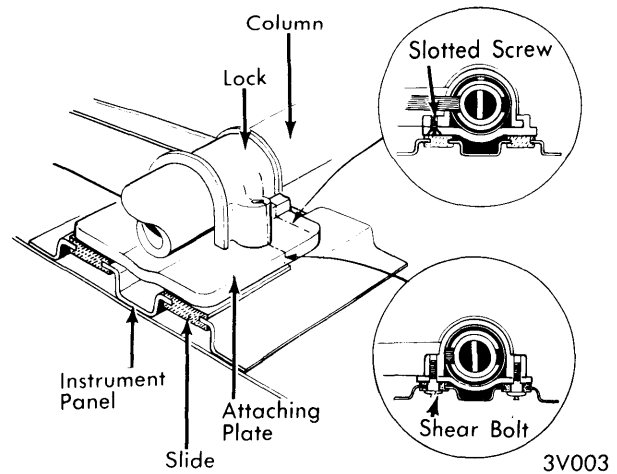

REMOVING COLUMN LOCK

## OVERHAUL

## UPPER BEARING (COLUMN IN VEHICLE)

Remove steering wheel and upper column cover. Detach turn signal switch from attachment on column. Remove switch attachment. Pull out column spring and seat. Remove upper bearing. Install new bearing and replace other components in reverse of removal procedure.

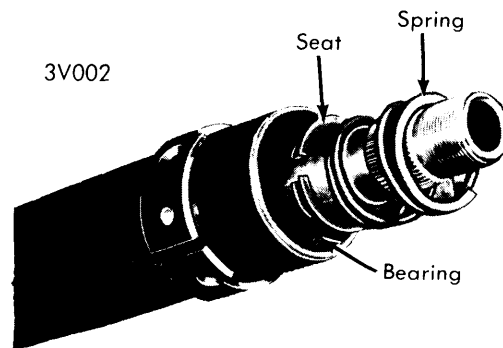

UPPER BEARING PLACEMENT