

Steering Columns

VOLKSWAGEN TYPE 4

Type 4
412

DESCRIPTION

Vehicles are equipped with energy-absorbing steering columns. Principle of design is based on tubular expanded metal section of column which collapses under impact, absorbing impact energy. Impact forces, working on column axially (as in head-on collision), push expanded metal section together. Lateral impact deforms column sideways. Column housing is attached to instrument panel with special mounting: guide pieces attached with plastic rivets. Impact force causes pins to shear off and guide pieces to slide from mounting. Shaft and housing are then pushed through the partition and deform the energy absorbing element.

REMOVAL & INSTALLATION

Removal — 1) Disconnect battery. Remove steering wheel and extract column circlip. Turn ignition key to "DRIVE" position. Pull steering coupling cover upward. Unscrew two Allen screws retaining column to flexible coupling. Detach horn ground cable.

2) Disconnect both multi-pin couplers below switch housing. Remove hex head screws for support bracket, and remove Allen screws for column switch. Remove steering column assembly from vehicle.

Installation — 1) Ensure mounting plate for column is centrally aligned and tight, with closed sides of aluminum slides pointing forward. Slip column switch onto tube and tighten slightly. Position column assembly in vehicle. Attach column to coupling. Place rubber boot over coupling.

2) Partly tighten screws securing switch to body and support ring to pedal bracket. Fit circlip on column, place steering gear in center position, and attach steering wheel with spokes horizontal.

3) Move column switch in slotted holes until space between steering wheel hub and switch is .08-.11" (2-3 mm). **NOTE** — Ensure switch is in center position to avoid damage to canceling ring. Tighten switch and support ring screws. Reconnect wiring couplers below switch.

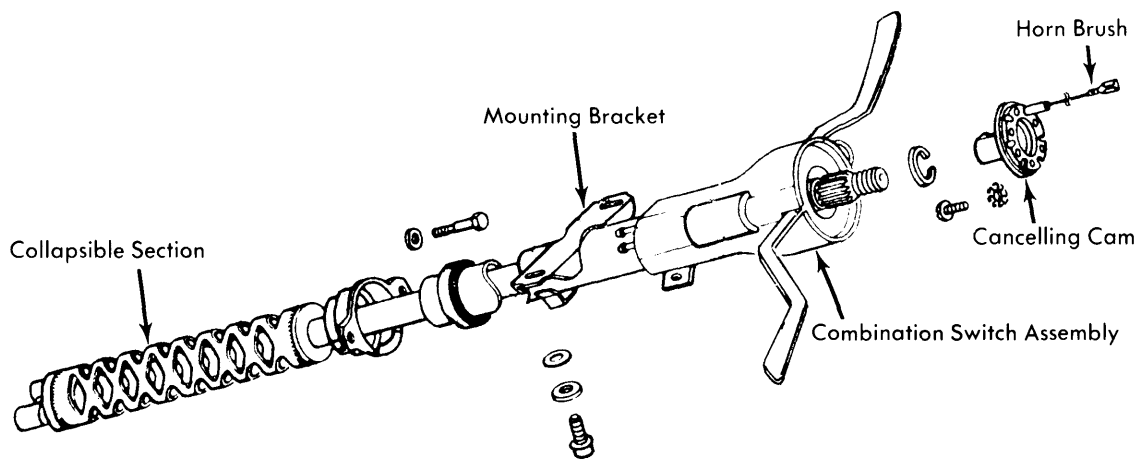

3VW412

VOLKSWAGEN TYPE 4 STEERING COLUMN