

TOYOTA, EXC. COROLLA & LAND CRUISER

Corona
Corona Mark II
Hi Lux Pickup
Celica

DESCRIPTION

Vehicles incorporate energy absorbing steering columns which collapse on impact. The steering main shaft telescopes inward while the column tube compacts around an expanded metal section. The main shaft is connected to the gear through a flexible coupling. Column is mounted to the instrument panel on a break-away bracket.

REMOVAL & INSTALLATION

Removal – 1) Loosen pinch bolt (as illustrated) attaching coupling yoke to worm shaft. Remove backup light switch and disconnect shift control shaft from levers (if equipped with column control). Unscrew steering wheel retaining nut and pull wheel from shaft.

2) Disconnect wiring harness for ignition switch, turn signal, horn, and light dimmer at receptacle under instrument panel. Remove turn signal switch. Unscrew column floor cover bolts. Detach lower instrument panel cover (if necessary). Unbolt break-away brackets. Draw column assembly toward inside of vehicle.

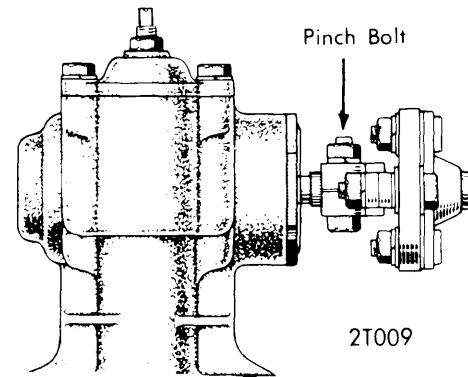

DISCONNECTING FLEXIBLE COUPLING

Installation – 1) Insert steering column through column hole from inside of vehicle, align coupling yoke on steering worm, and tighten pinch bolt. *NOTE* – Yoke and worm are in proper alignment when yoke bolt hole is aligned with cut-away portion of worm spline.

2) Coat break-away bracket center portion with suitable weatherstrip adhesive (08704-00020). Finger tighten break-away bracket bolts. Tighten column hole cover bolts and break-away brackets nuts, then insert and tighten center bracket retaining bolt.

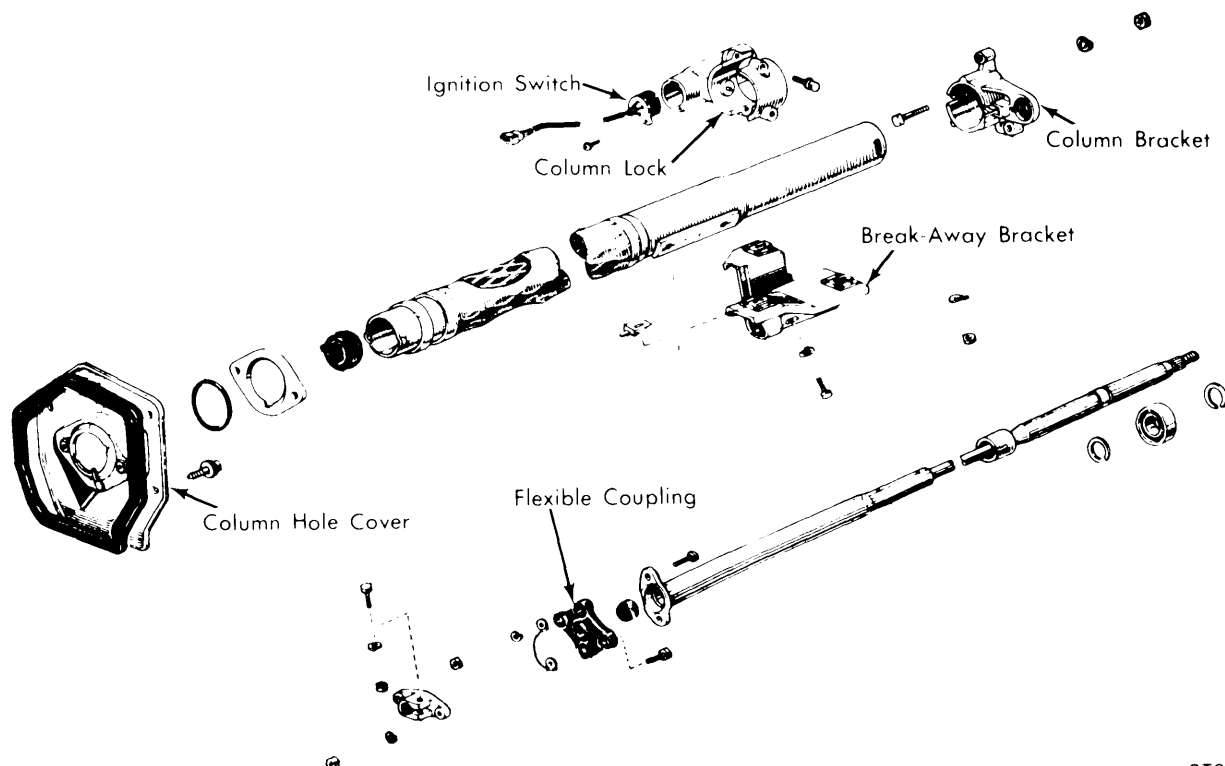

2T0010

ENERGY ABSORBING COLUMN – TYPICAL