

## 1968-73 VOLKSWAGEN TYPE 2

### Type 2 Transporter (1968-73)

#### DESCRIPTION

Independent torsion bar type rear suspension. Torsion bars mount in rear crossmember tube and anchor in center of tube by means of a splined hub. Outer ends of torsion bars mount into splined hubs integral with spring plates which connect at ends to control arms. Control arms pivot in mounts connected to crossmember tube and connect at end to rear wheel bearing carrier. Hydraulic shock absorbers mount between control arms and bracket integral with chassis member.

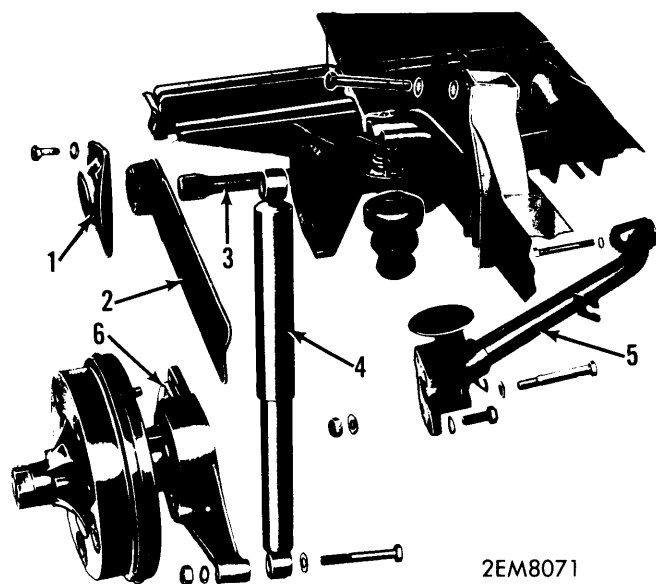

- 1 - Hub Cover
- 2 - Spring Plate
- 3 - Torsion Bar
- 4 - Shock Absorber
- 5 - Control Arm
- 6 - Rear Axle Bearing Carrier

### VOLKSWAGEN TYPE 2 REAR SUSPENSION (1968-72)

#### ADJUSTMENT

**WHEEL ALIGNMENT SPECIFICATIONS & PROCEDURES** — See Volkswagen Type 2 Rear Wheel Alignment Specifications and Procedures in WHEEL ALIGNMENT Section.

#### REMOVAL & INSTALLATION

##### CONTROL ARMS

**Removal** — Remove cotter pin and loosen rear axle hub nut. Raise vehicle and place safety stands under body. Remove wheel and tire. Remove bolts from axle shaft at outside flange and separate axle shaft from flange. Disconnect shock absorber from control arm. Disconnect brake line and parking brake cable from backing plate. Mark position of spring plate in relation with control arm. Remove bolts securing spring plate to control arm. Remove control arm pivot bolt and remove control arm from vehicle.

**Installation** — Install control arm in vehicle in extended position and tighten pivot bolt to specification. Attach control arm to spring plate, align marks and tighten bolts to specifications. Reverse removal procedure to install remaining components and tighten all bolts and nuts to specifications. Check wheel alignment if new control arm was installed.

##### SPRING PLATES & TORSION BARS

**Removal** — Disconnect spring plate from control arm as previously outlined. Remove bolts securing hub cover to crossmember and remove hub cover. Pry spring plate off of lower stop and pull spring plate out. Withdraw torsion bar. If broken torsion bar is being removed, opposite side torsion bar must be removed to drive out broken piece.

**Installation** — Inspect torsion bar and spring plate for wear or distortion. Inspect rubber support bushings for wear or cracking. Grease torsion bar splines and install in vehicle. Torsion bars are marked left and right, install accordingly if both torsion bars have been removed. Coat rubber bushings with talcum powder before installing. Install spring plate on torsion bar in proper position. *NOTE* — See appropriate story in WHEEL ALIGNMENT Section for torsion bar setting procedure. Install rubber bushing and hub cover and secure hub cover with two bolts. Raise spring plate using a suitable spring compressor (VW655/3), install remaining bolts and tighten to specifications. Reverse removal procedure for installation of remaining components. Tighten all bolts and nuts to specifications and check wheel alignment.

#### TIGHTENING SPECIFICATIONS

Application	Ft. Lbs. (mkg)
Shock Absorber Mounts .....	87 (12)
Control Arm-to-Bearing Carrier Bolts.....	94 (13)
Hub Cover Bolts .....	32 (4.4)
Control Arm Pivot Bolt .....	58 (8)
Rear Axle Hub Nut.....	253 (35)
Axle Shaft-to-Flange Bolts.....	25 (3.5)
Spring Plate Bushing Cover.....	32 (4.4)