

## 1972-73 TOYOTA CORONA MARK II

Corona Mark II, Exc. Station Wagon (1972-73)

### DESCRIPTION

Coil spring type rear suspension utilizing upper and lower control arms as pivot supports. Coil springs are mounted between axle housing and chassis member. Hydraulic shock absorbers are mounted between axle housing and chassis member. A side strut rod is mounted to rear side of axle housing and runs parallel with housing to mount at side of chassis member.

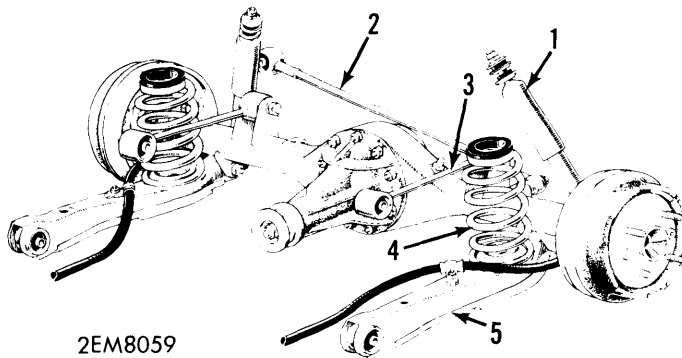

- 1 - Shock Absorbers
- 2 - Side Strut Rod
- 3 - Upper Control Arm
- 4 - Coil Spring
- 5 - Lower Control Arm

### TOYOTA CORONA MARK II REAR SUSPENSION

### REMOVAL & INSTALLATION

#### SHOCK ABSORBERS

**Removal** - Raise vehicle and place safety stands under axle housing. Remove bolts from upper and lower shock absorber mount and remove shock absorber.

**Installation** - Reverse removal procedure for installation. Tighten upper and lower mounting bolts to specifications.

#### COIL SPRINGS

**Removal** - Raise vehicle by jacking up under center of axle housing. Place safety stands under body and leave jack in place. Disconnect lower end of shock absorber and lower jack until coil springs and insulators can be removed.

**Installation** - Reverse removal procedure for installation. Tighten shock absorber lower mount to specification.

#### UPPER CONTROL ARMS

**Removal** - Raise vehicle by jacking up under center of axle housing. Place safety stands under body and leave jack in place. Remove upper control arm pivot bolts and remove arm. If bushings are defective, press out using a suitable mandrel (09716-30010).

**Installation** - Press new bushings into control arm using a suitable mandrel (09716-30010). Install control arm in vehicle. Tighten pivot bolts to specification with weight of vehicle on rear wheels.

#### LOWER CONTROL ARMS

**Removal** - Raise vehicle by jacking up under center of axle housing. Place safety stands under body and leave jack in place. If left side control arm is being removed, parking brake cable clamp must be removed before removing pivot bolts. If right side control arm is being removed, tailpipe support brackets must be removed before removing pivot bolts. With bolts removed, remove control arm. If bushings are defective press out using a suitable mandrel (09716-30010).

**Installation** - Press new bushings into control arm using a suitable mandrel (09716-30010). Install control arm in vehicle. Tighten pivot bolts to specification with weight of vehicle on rear wheels.

#### SIDE STRUT ROD

**Removal** - Raise vehicle by jacking up under center of axle housing. Place safety stands under body and leave jack in place. Disconnect shock absorber lower end. Remove nut securing side strut rod to axle housing. Remove bolt from body mount and remove side strut rod from vehicle. Using a suitable mandrel (09716-30020), press bushing out of strut rod.

**Installation** - Press bushing into strut rod using a suitable mandrel (09716-30020). Install strut rod in vehicle. Tighten bolt and nut to specifications with weight of vehicle on front wheels.

### TIGHTENING SPECIFICATIONS

Application	Ft. Lbs. (mkg)
Shock Absorber Upper Mount .....	18 (2.5)
Shock Absorber Lower Mount.....	30 (4.1)
Control Arm Pivot Bolts .....	125 (17)
Side Strut Rod-to-Axle Housing.....	68 (9.4)
Side Strut Rod-to-Body Mount .....	73 (10.1)