

Rear Suspension

1971-73 RENAULT R-12, R-15 & R-17

R-12 (1971-73)
 R-15 (1972-73)
 R-17 (1972-73)

DESCRIPTION

Link type rear suspension with coil springs. Upper link is wishbone shaped and is attached to top of axle beam and to the body. Side strut is connected to body and front of axle beam. Shock absorbers are mounted inside coil springs between axle beam and body. A stabilizer bar connects both side struts.

REMOVAL & INSTALLATION

UPPER LINK

Removal - Raise and support vehicle. Disconnect brake limiter control. Remove nuts securing upper link hinge pin and nuts attaching upper link to axle beam. Slide hinge pin out towards left side of vehicle and remove upper link.

Installation - To install, lubricate hinge pins and reverse removal procedure. Tighten all nuts and bolts to specification.

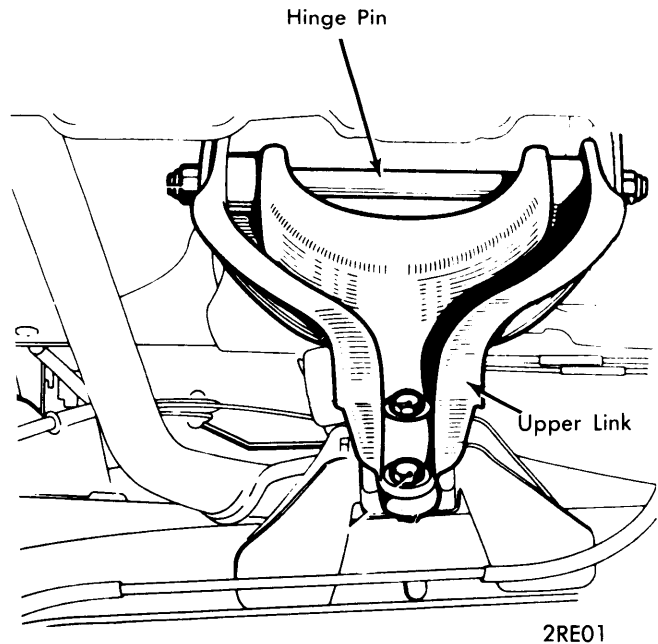

UPPER LINK

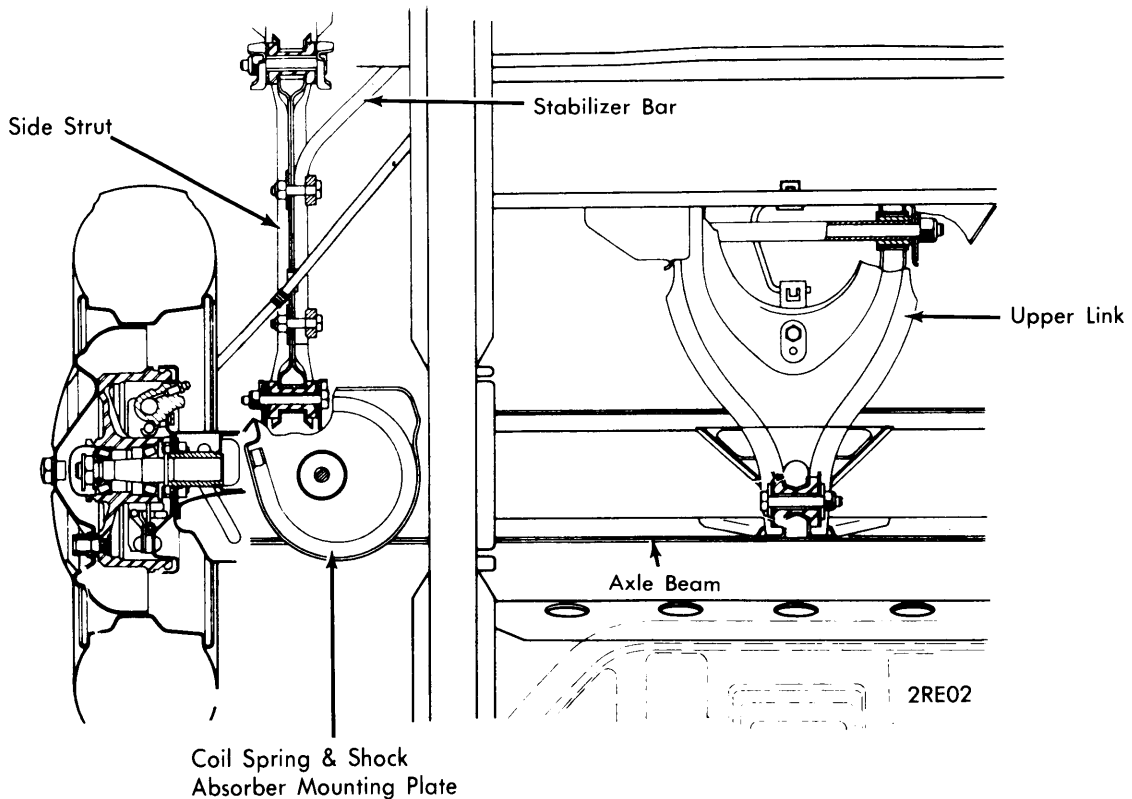

REAR SUSPENSION ASSEMBLY (TOP VIEW)

1971-73 RENAULT R-12, R-15 & R-17 (Cont.)

SIDE STRUT

Removal – Raise and support vehicle. On vehicles fitted with brake drums, remove the drum. Disconnect parking brake cable from lever and remove from backing plate. Free cable through side strut. Remove bolts securing stabilizer bar and nuts securing hinge pins. Remove side strut.

Installation – To install, lubricate hinge pins and reverse removal procedure. Tighten all nuts and bolts.

COIL SPRINGS

Removal – Raise and support vehicle. Disconnect shock absorber at lower mount and push shock absorber up as far as possible. Place a jack between side strut and floor of vehicle and tilt rear axle beam down. Remove coil spring.

Installation – Inspect for signs of wear or damage. To install, reverse removal procedure.

AXLE BEAM

Removal – Raise and support vehicle. Disconnect shock absorbers and push up as far as possible. Remove coil springs and remove brake drums. Disconnect parking brake cable and withdraw from backing plates. Remove nuts from side strut hinge pins and remove pins. Disconnect brake lines on rear axle beam. Place jack under axle beam and disconnect upper links. Remove axle beam.

Installation – To install, lubricate hinge pins and reverse removal procedure. Bleed and adjust rear brakes.

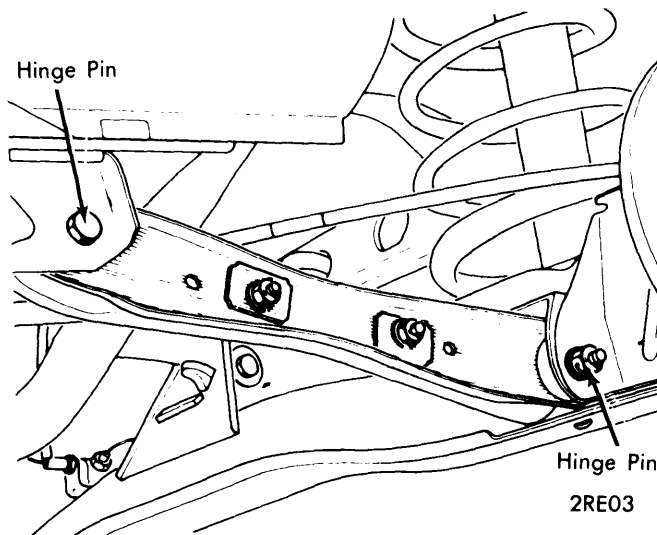

SIDE STRUT

TIGHTENING SPECIFICATIONS

Application	Ft. Lbs. (mkg)
Side Strut Hinge Pins	20 (2.8)
Upper Link Hinge Pins	80 (11.1)
Upper Arm Center Bearing	10 (1.4)