

## 1968-73 MERCEDES-BENZ SEMI-TRAILING ARM TYPE

200/8, 200 D/8 (1968-72)  
220/8, 220 D/8 (1968-73)  
230/8 (1968-72)  
250/8 (1968-72)  
280 (1973)  
350 SL (1971-72)  
450 SL, 450 SLC (1973)  
450 SE, 450 SEL (1973)

### DESCRIPTION

Rear suspension is independent with coil springs and semi-trailing arms. Rear axle carrier is mounted to body at three points and supports rear axle assembly. Axle shafts serve as upper control arms to rear wheels. Wheel hubs are supported by semi-trailing arms which run forward to pivot points on rear axle carrier and body. Shock absorbers are mounted inside of coil springs, attached to body on top and to semi-trailing arms on bottom. Stabilizer bar is mounted to body and to wheel hubs at ends.

### ADJUSTMENT

#### WHEEL ALIGNMENT SPECIFICATIONS & PROCEDURES

See *Wheel Alignment Specifications & Procedures* in *WHEEL ALIGNMENT* Section.

### REMOVAL & INSTALLATION

#### SHOCK ABSORBERS (REAR)

*NOTE* — Rear shock absorbers serve as deflection stops for rear wheels. Shock absorber should be removed only when vehicle is on wheels or when semi-trailing arm is supported.

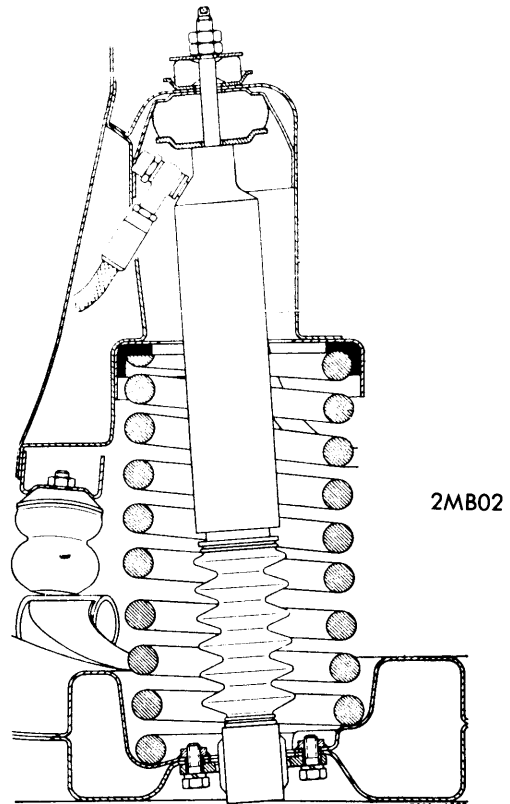

REAR SPRING & SHOCK ABSORBER

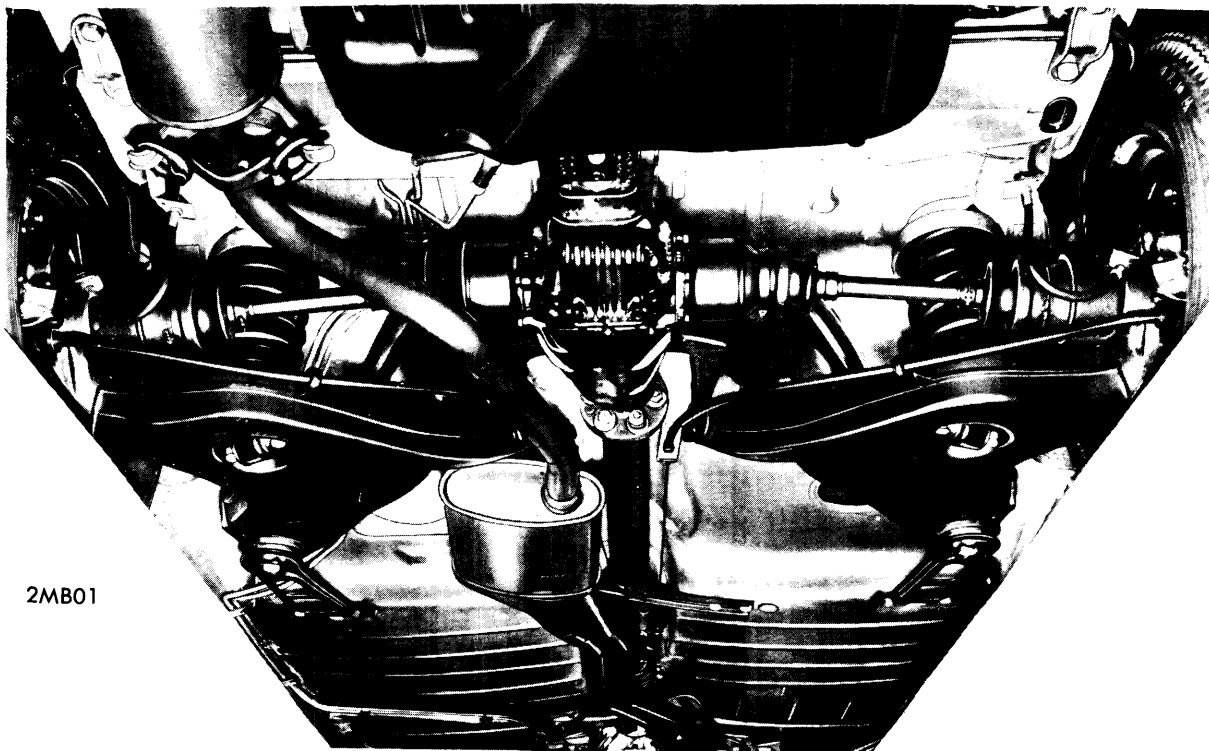

REAR SUSPENSION (TYPICAL)

# Rear Suspension

## 1968-73 MERCEDES-BENZ SEMI-TRAILING ARM TYPE (Cont.)

**Removal** – Vehicles with coupe top, remove top and open flap. All models, remove rear seat and backrest. Remove locking lever off of top flap and unscrew lining. Remove nut and rubber ring of upper shock mount. Remove lower shock mount on semi-trailing arm. Remove shock absorber in a downward direction.

**Installation** – To install rear shock absorbers, reverse removal procedure and tighten to specifications.

### COIL SPRINGS (REAR)

**Removal** – Remove shock absorber as previously outlined. Raise and support rear of vehicle on safety stands. Raise semi-trailing arm until it is approximately level. Using suitable spring compressor (115 589 00 31 00), compress spring. Carefully lower semi-trailing arm and remove spring with rubber mounting.

**Installation** – To install rear coil spring, reverse removal and tighten to specifications.

### REAR STABILIZER BAR

**Removal** – Raise and support rear of vehicle with safety stands, remove wheels. Disconnect connecting rod from stabilizer on both sides of vehicle. Remove stabilizer bar holding brackets. Loosen exhaust pipe mounts (rubber rings) and lower slightly. Remove stabilizer bar in a downward direction.

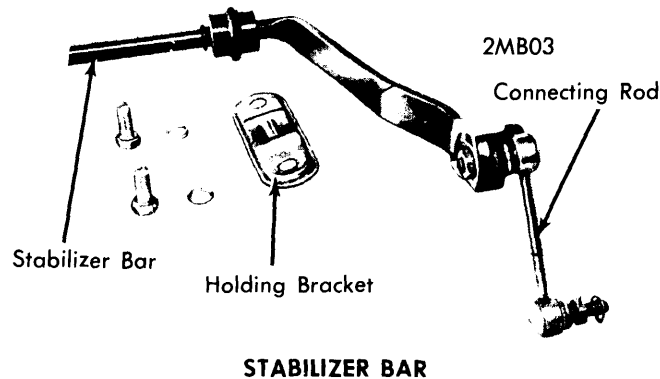

**Installation** – To install rear stabilizer bar, reverse removal procedure. Tighten nuts and bolts to specifications.

### REAR SUSPENSION & AXLE

**Removal** – 1) Raise and support vehicle with safety stands, remove wheels. Disconnect and remove exhaust system. Disconnect parking brake control cables at frame and compensating lever. On 350 SL, remove shielding plate and shock absorber.

2) Loosen clamp nut and disconnect drive shaft intermediate bearing from frame. *NOTE* – On three piece drive shaft, loosen front clamp nut only. Disconnect rear of drive shaft and slide forward, out of centering position.

3) Remove shock absorber (except on model 350 SL), and coil springs as previously outlined. Disconnect and plug brake lines. Disconnect stabilizer bar holding clamps from frame.

4) Place jack with suitable jack top (116 589 10 61 00) under rear suspension. Disconnect supporting plates, front and rear rubber mounts from frame. Carefully lower jack and remove rear suspension from vehicle. Remove rear rubber mount from axle.

*CAUTION* – When lowering and moving rear suspension, make sure cover plates of disc brakes are not damaged.

**Installation** – To install rear suspension and axle, reverse removal procedure. Tighten all nuts and bolts to specifications.

### DIFFERENTIAL WITH AXLE SHAFTS

**Removal** – 1) Drain oil from differential. Disconnect brake caliper on right hand side and support to prevent damage to brake line. Remove bolt attaching rear axle shafts to rear axle shaft flanges, on both sides, and force rear axle shafts out of rear axle shaft flanges. *NOTE* – If required, loosen right side rear shock absorber at upper mount and lower semi-trailing arm to deflection stop.

2) If required, remove exhaust system. Loosen clamp nut and disconnect drive shaft intermediate bearing from frame. *NOTE* – On three piece drive shaft, loosen front clamp nut only. Disconnect drive shaft from differential and push out of centering alignment.

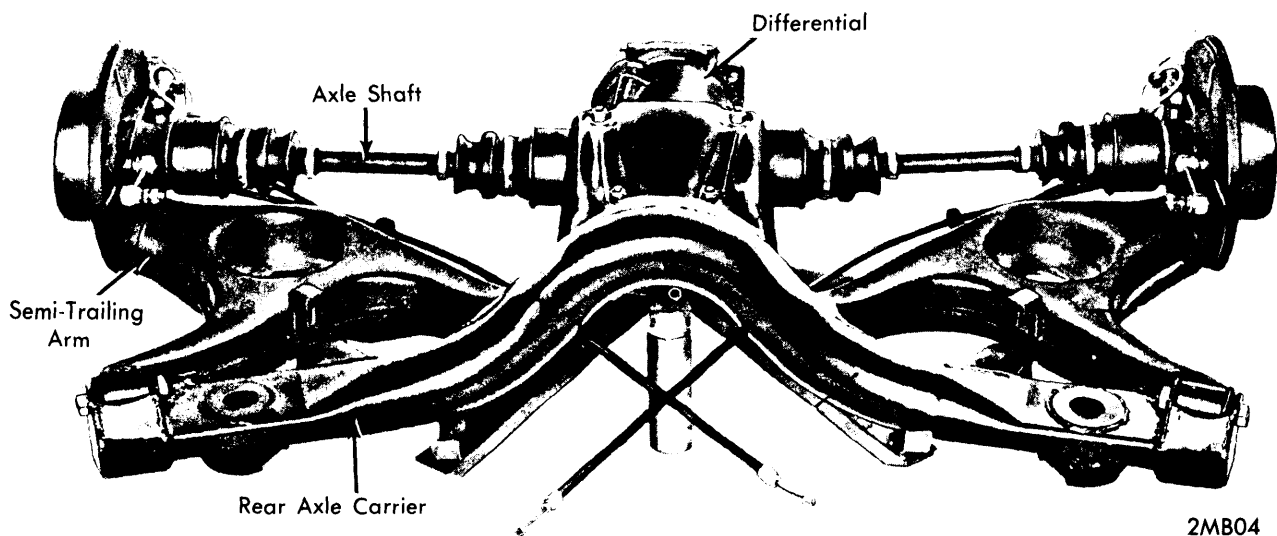

REAR SUSPENSION (TYPICAL)

## 1968-73 MERCEDES-BENZ SEMI-TRAILING ARM TYPE (Cont.)

3) Support differential with jack and suitable support (115 589 35 63 00). Disconnect rear rubber mount from body. Disconnect differential from rear axle carrier. Lower jack and remove differential with axle shafts.

**CAUTION** — When moving differential with axle shafts, make sure that axle shafts are supported and do not drop down, as this might damage inner joints.

**Installation** — Check all rubber parts and replace as necessary. To install differential with rear axle shafts, reverse removal procedure. Tighten nuts and bolts to specifications except, when connecting drive shaft to differential do not torque until vehicle is rolled forwards and backwards a few times, then torque drive shaft clamp nut to specification. Install exhaust system, if removed.

### REAR AXLE CARRIER

**Removal** — Remove rear suspension, differential with rear axle shafts and semi-trailing arms as previously outlined.

**Inspection** — Using inspection device (115 589 04 23 00) check rear axle carrier. When checking rear axle carriers without spot welded washers, place a .098" (2.5 mm) thick washer under receiving bolt (see illustration).

**Installation** — To install rear axle carrier, reverse removal procedure. Tighten nuts and bolts to specifications.

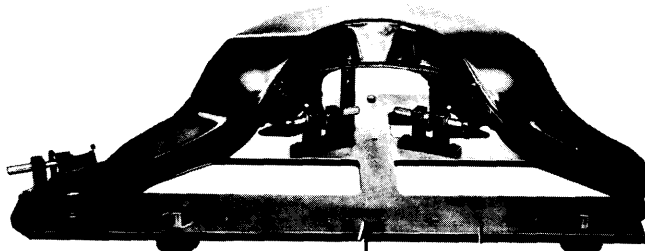

Inspection Device

2MB07

### INSPECTION DEVICE

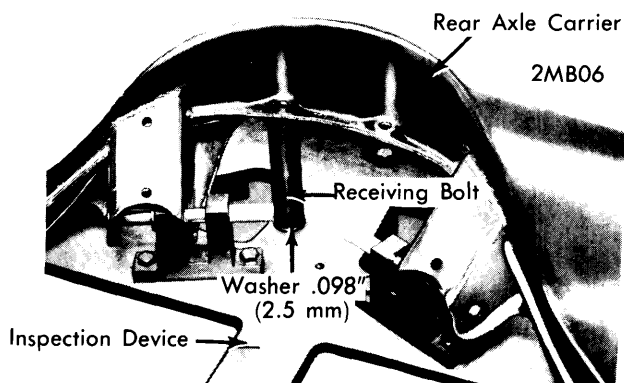

WASHER PLACEMENT

### TIGHTENING SPECIFICATIONS

Application	Ft. Lbs. (mkg)
Shock Absorber Lower Mount .....	33 (4.6)
Torsion Bar Bearing Bolts .....	47 (6.5)
Torsion Bar Connecting Rod Ball Joints .....	33 (4.6)
Rear Rubber Mount-to-End Cover	
350 SL .....	87 (12)
All Others .....	101 (14)
Rear Rubber Mount-to-Frame .....	18 (2.5)
Front Rubber Mounts-to-Frame .....	29 (4)
Supporting Plate-to-Frame .....	25 (3.5)
Clamp Nut of Drive Shaft	
Two Piece .....	145 (20)
Three Piece Front .....	25 (3.5)
Three Piece Rear .....	145 (20)
Semi-Trailing Arm-to-Rear	
Axle Carrier .....	87 (12)
Axle Shaft-to-Axle Shaft Flange .....	69 (9.5)
Differential-to-Rear Axle Carrier .....	72 (10)
Brake Caliper Bolts .....	25 (3.5)