

1966-73 VOLKSWAGEN TYPE 1 & KARMANN GHIA, EXCEPT SUPER BEETLE

Sedan, Exc. Super Beetle (1966-73)
 Convertible, Exc. Super Beetle (1966-73)
 Karmann Ghia (1966-73)

DESCRIPTION

Independent ball joint type suspension using torsion bars. Front axle beam consists of two horizontal tubes held together at ends by endplates welded to tubes. Torsion bars are mounted inside tubes and are anchored in center. Torsion arms are connected to ends of torsion bars and mount to steering knuckle by means of ball joints. Hydraulic shock absorbers are mounted between lower torsion arms at bottom and to mounts integral with endplates at top. A stabilizer bar is mounted to lower torsion arms.

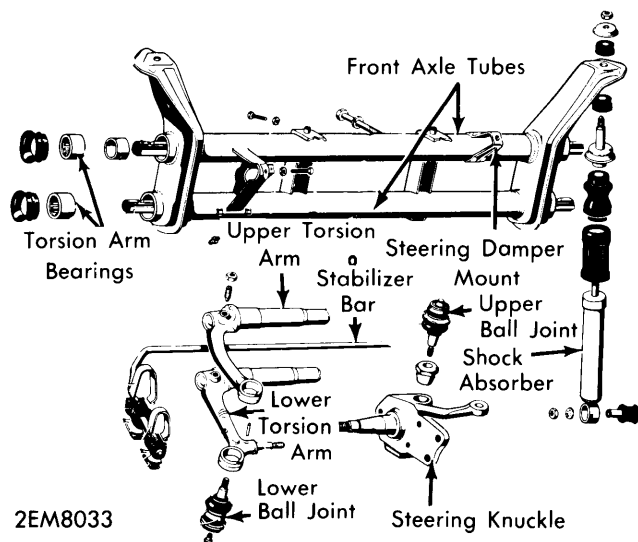

VOLKSWAGEN SEDAN FRONT
 SUSPENSION COMPONENTS

ADJUSTMENT

WHEEL ALIGNMENT SPECIFICATIONS & PROCEDURES

See *Wheel Alignment Specifications & Procedures* in *WHEEL ALIGNMENT* Section.

WHEEL BEARING ADJUSTMENT

See *Wheel Bearing Adjustment* in *WHEEL ALIGNMENT* Section.

BALL JOINT CHECKING

See *Ball Joint Checking* in *WHEEL ALIGNMENT* Section.

REMOVAL & INSTALLATION

FRONT AXLE ASSEMBLY

Removal — Most repairs to front end components can be accomplished with axle assembly in vehicle, but entire assembly can be removed. Disconnect fuel line and plug. Remove fuel tank. Remove steering column clamp bolt and disconnect steering shaft from coupling. Raise vehicle and place safety stands under body. Remove tires and wheels. Remove cotter pin in speedometer cable in left wheel and slide cable out of steering knuckle. Disconnect brake hoses at brackets and plug brake lines. Disconnect steering damper at front axle bracket.

Remove nuts on tie-rod studs on long tie-rod and separate ends from mounts. Remove tie-rod from vehicle. Remove two bolts securing body to upper axle mounts. Using a suitable holding fixture secured to a floor jack (VW 610), attach to front axle assembly. Remove four mounting bolts and remove axle from vehicle.

Installation — Reverse removal procedure for installation. Tighten all bolts and nuts to specifications and bleed brake system. Check wheel alignment.

STEERING KNUCKLE

Removal — Raise vehicle and place safety stands under body. Remove tire and wheel. If equipped with drum brakes, disconnect brake hose at bracket and plug line. Remove brake drum and backing plate. If equipped with disc brakes, remove brake caliper and tie to brake line bracket with a piece of wire. Remove rotor (brake disc) and splash shield. Remove lower ball joint stud nut and separate from steering knuckle using a suitable tool (VW267A). Remove upper ball joint stud nut and loosen eccentric bushing. Using same tool as used on lower ball joint, separate ball joint from steering knuckle. Using a suitable tool (VW655/3), lift upper torsion arm enough to remove ball joint from steering knuckle. Lift off of lower ball joint and remove from vehicle.

Installation — Reverse removal procedure for installation. Set Eccentric nut with notch for camber adjustment pointing forward. Tighten all bolts and nuts to specification. Bleed brake system and check wheel alignment.

TORSION ARMS & BARS

Removal — Remove steering knuckle as previously outlined. Disconnect stabilizer bar if lower torsion arm is to be removed. Remove securing pin lock-nut and securing pin. Slide torsion arm out of tube. If torsion bar is to be removed, both steering knuckles must be removed. With torsion arm removed from one side, remove lock-nut and securing pin from center of tube and slide torsion bar and arm out of tube.

Disassembly — Ball joints are replaceable and can be removed from torsion arm by pressing out using a suitable driver. When pressing ball joints into torsion arms make sure grooves in ball joint are lined up with grooves in torsion arm eye. If ball joint presses into torsion arm too easily, rotate ball joint 45° until notches in ball joint line up with grooves in torsion arm eye. Bearings in end of axle tubes can be removed using a suitable puller (VW771). Install using a suitable driver (VW768 Upper and VW767 Lower). Drive in until shoulder of driver contacts axle tube.

Installation — Reverse removal procedure for installation. Tighten all bolts and nuts to specifications. Grease all front axle fittings. Bleed brake system and check wheel alignment.

SHOCK ABSORBERS

Removal — Raise vehicle and remove tire and wheel. Remove nut from upper shock absorber mount. Remove nut from lower mounting pin and remove shock absorber.

Installation — Reverse removal procedure for installation. Tighten all bolts and nuts to specifications.

Front Suspension

1966-73 VOLKSWAGEN TYPE 1 & KARMANN GHIA, EXCEPT SUPER BEETLE (Cont.)

TIGHTENING SPECIFICATIONS

Application	Ft. Lbs. (mkg)
Ball Joint Nuts	① 43 (5.9)
Torsion Bar Securing Pin	34 (4.7)
Securing Pin Lock Nut	34 (4.7)
Steering Damper-to-Axle Bolt	31 (4.3)
Tie-Rod Stud Nuts	20 (2.8)
Steering Coupling Bolt	16 (2.2)
Brake Caliper Bolts	29 (4)
Shock Absorber Mounts	24 (3.3)

① — Use new self-locking nut.