

1971-73 MAZDA 616, RX2, 808 & RX3

616 (1971-72)
 RX2 (1971-73)
 808 (1972-73)
 RX3 (1972-73)

DESCRIPTION

Independent strut type suspension with coil springs. Strut assemblies are mounted between lower control arms and upper fender panels. Strut assemblies consist of; a shock absorber built into strut outer tube, a coil spring mounted on outside of strut outer tube, and a steering knuckle integral with bottom of strut tube. Lower control arms pivot in mounts connected to crossmember and connect at outer ends to strut assemblies by means of ball joints. A stabilizer bar is mounted to front chassis members and connects at ends to lower control arms.

ADJUSTMENT

WHEEL ALIGNMENT SPECIFICATIONS & PROCEDURES

See *Wheel Alignment Specifications & Procedures* in **WHEEL ALIGNMENT** Section.

WHEEL BEARING ADJUSTMENT

See *Wheel Bearing Adjustment* in **WHEEL ALIGNMENT** Section.

BALL JOINT CHECKING

See *Ball Joint Checking* in **WHEEL ALIGNMENT** Section.

REMOVAL & INSTALLATION

STRUT ASSEMBLY

Removal — Raise vehicle and place safety stands under body. Remove wheel and tire. Remove three nuts retaining strut assembly to fender panel, accessible from inside engine compartment. Remove brake caliper and rotor (disc). **NOTE** — See appropriate story in **BRAKE SYSTEMS** Section for brake components removal. Remove two bolts from bottom of steering arm and remove strut assembly from vehicle.

Disassembly (Mazda 616 & RX2) — Secure strut assembly in a vise. Using a suitable spring compressor (49 0223 640A and 49 0223 641), compress coil spring. Remove nut from upper piston rod and remove mounting rubber, bearing, rubber seal, upper spring seat, upper rubber seat, adjusting plate, seal ring, dust boot, coil spring, and lower spring seat. Using a suitable wrench (49 0259 700), remove cap nut and seal from top of strut tube. Remove "O" ring from inside strut tube and pull up to remove piston rod and pull from pressure tube. Remove piston rod guide, back-up ring, stopper and stopper guide. Secure upper portion of piston rod in a vise and remove nut from top. With nut removed, slide off washer, centering valve, relief valves, piston, check valves, check valve springs, and washer. Separate piston ring from piston with a pair of snap ring pliers. Slide pressure tube out from inside strut tube and remove valve from bottom of pressure tube. Remove bolt and nut from valve assembly and remove valve seat, relief valves, base valve casing and relief valves.

Disassembly (RX3 & 808) — Clamp strut in a vise. Using a suitable spring compressor (49 0223 640A and 49 0223 641), compress coil spring. Remove nut from top of piston rod and

remove upper support, spring seat, coil spring, dust seal, damper stopper, and dust cover. Using a suitable wrench (49 0259 700A), remove cap nut from top of strut tube. Remove "O" ring from inside strut tube and pull out pressure tube assembly. Slide piston rod guide, back-up ring, stopper and stopper guide from piston rod. Remove base valve assembly from bottom of pressure tube. Remove bolt and nut from valve assembly and remove valve seat, relief valves, base valve casing and relief valves. Slide piston rod from pressure tube and secure upper portion of piston rod in a vise. Remove nut from piston rod and slide off washer, centering valve, relief valves, piston check valves, check valve springs, and washer.

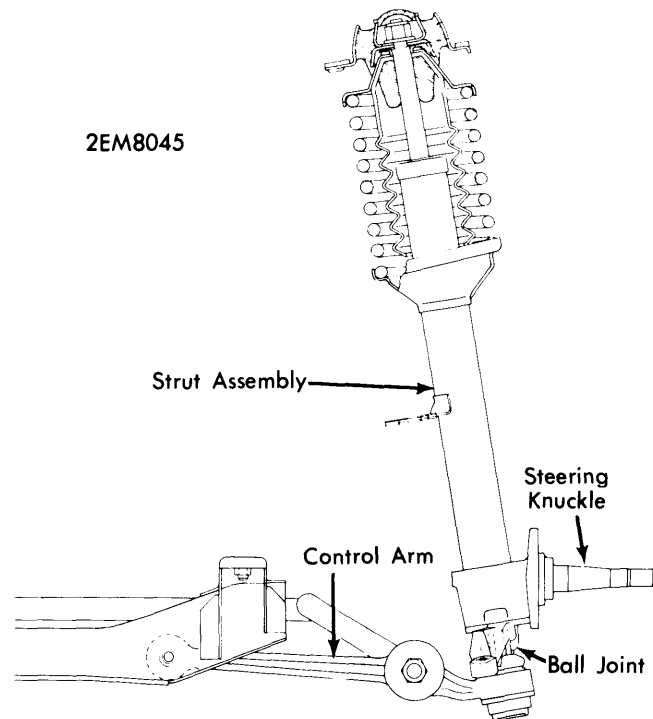
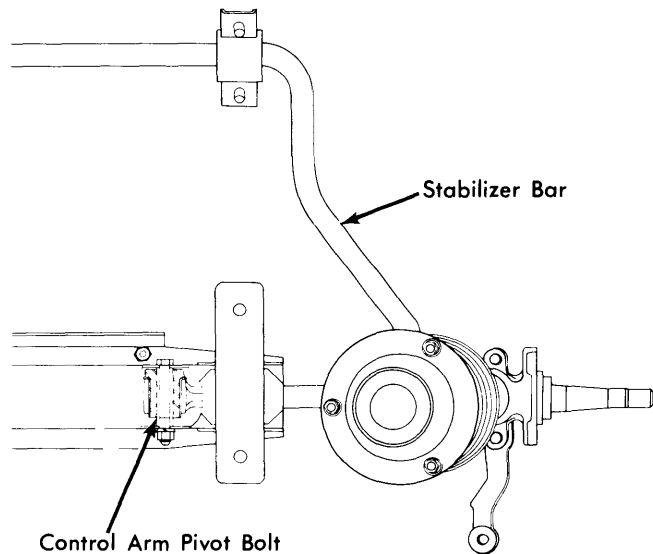

MAZDA 616, RX2 & RX3 FRONT SUSPENSION (TYPICAL)

Front Suspension

1971-73 MAZDA 616, RX2, 808 & RX3 (Cont.)

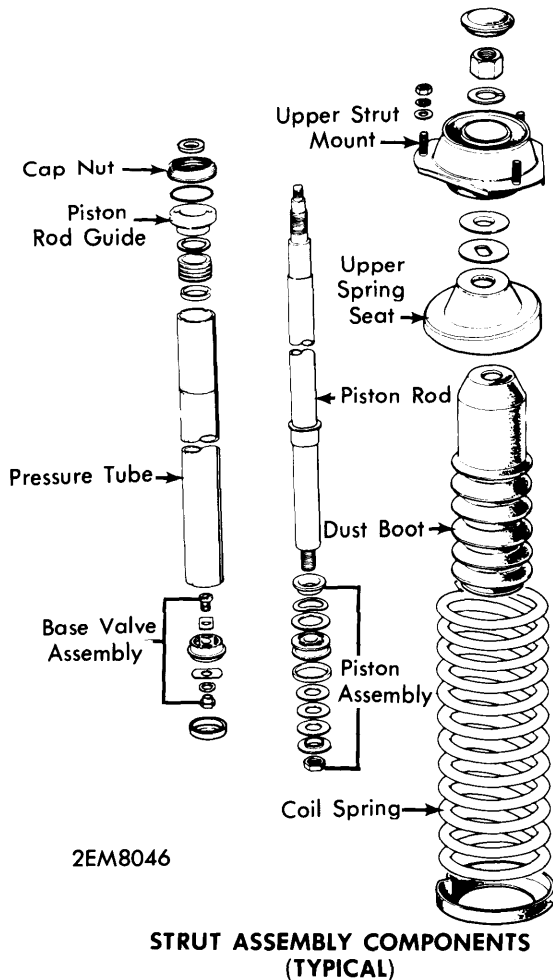

piston is installed with constant orifice side up. Tighten nut to specification and stake around edge of nut to keep from working loose. Install four relief valves on bolt and install in base valve casing. Place five relief valves, washer and nut and tighten nut to specification. Stake in center of nut to prevent from working loose. Install piston rod into pressure tube from bottom and place stopper guide on piston rod with grooves toward base valve. Place stopper and back-up ring on piston rod. Insert base valve in bottom of pressure tube. Place one oil stop ring 5.12" from bottom and second oil stop ring 2.36" from bottom. Place pressure tube assembly in strut tube and fill with 16.5 cu. in. (270 cc) of shock absorber oil. Insert rod guide into strut tube along with "O" ring. Place oil seal guide (49 0370 590) on end of piston rod and install cap nut. Tighten temporarily making sure piston rod is pulled out to end of stroke. Push piston rod to bottom of stroke and tighten cap nut to specification. Install coil spring and components in reverse of removal order and tighten nut to specification.

Installation - To install, reverse removal procedure. Tighten all bolts and nuts to specifications.

CONTROL ARM

Removal - Raise vehicle and support with safety stands. Remove wheel and tire. Remove nut from tie-rod end stud and separate tie-rod from steering arm using a suitable puller (49 0118 850C). Remove bolts securing steering arm to strut tube. Remove nut securing stabilizer bar to control arm. Remove pivot bolt and separate control arm from crossmember. Pull out on strut assembly and remove control arm from vehicle. Remove cotter pin and nut from ball joint stud and separate from steering arm using a suitable puller (49 0727 575). If ball joint is damaged and requires removal, remove set ring and dust seal and press out of control arm using a suitable mandrel (49 0370 860).

Installation - Inspect control arm for distortion or wear. Thoroughly clean ball joint and mounting bore in control arm before assembling. Press ball joint into control arm using a suitable mandrel (49 037 860). Place steering arm on ball joint and tighten nut to specification. Reverse removal procedure to install and tighten all bolts and nuts to specification.

Assembly (616 & RX2) - Inspect all components for wear or damage. Piston rod diameter should be no smaller than 0.785" and pressure tube inside diameter should be not less than 1.184". Place piston ring on piston. Secure upper piston rod in a vise and install components in reverse of removal order. *NOTE* - Make sure constant orifice side of piston faces upper end of piston rod. Tighten nut to specification and stake around nut to prevent from working loose. Place four tension valves on bolt and install in base valve casing. Install five compression valves, washer and nut in casing and tighten nut to specification. Stake in center of nut to prevent from working loose. Install stopper guide, stopper, back-up ring and piston rod guide in pressure tube. Place one oil stop ring 5.12" from end of pressure tube and second oil stop ring 2.36" from end. Install piston rod and components in pressure tube. Place base valve on bottom of pressure tube and slide pressure tube assembly into strut tube. Fill strut tube with 15.94 cu. in. (245 cc) of suitable shock absorber oil. Install "O" ring and cap nut and tighten temporarily. Push piston rod to end of stroke and tighten to specification. Install coil spring and components in reverse of removal order and tighten upper piston rod nut to specifications.

Assembly (RX3 & 808) - Check all components for wear or damage. Piston rod diameter should be no smaller than 0.785" and pressure tube inside diameter should be no less than 1.184". Place upper end of piston rod in a vise and install components in reverse of removal order. *NOTE* - Make sure

TIGHTENING SPECIFICATIONS

Application	Ft. Lbs. (mkg)
Control Arm Pivot Bolt	
616 & RX2	60 (8.3)
808 & RX3	34 (4.7)
Ball Joint Stud Nut	65 (9)
Piston Rod Nut	10 (1.4)
Base Valve Bolt	
616 & RX2	1 (.1)
808 & RX3	2 (.3)
Cap Nut	40 (5.5)
Strut Assembly Upper Mounting Nuts	47 (6.5)
Steering Armto-Strut Assembly Bolts	47 (6.5)