

1972-73 CHEVROLET LUV PICKUP

LUV (1972-73)

DESCRIPTION

Independent type suspension, using torsion bars. Upper control arms are mounted to bracket which is part of shock tower. Lower control arm is mounted to crossmember. Ball joints attach both upper and lower control arms to steering knuckles, which are part of the front wheel spindle. Torsion bars are connected in front to lower control arm and at rear to frame crossmember. Back and forth movement of front suspension is regulated by a strut bar connecting lower control arm to frame, by means of a rubber bumper at frame end of strut.

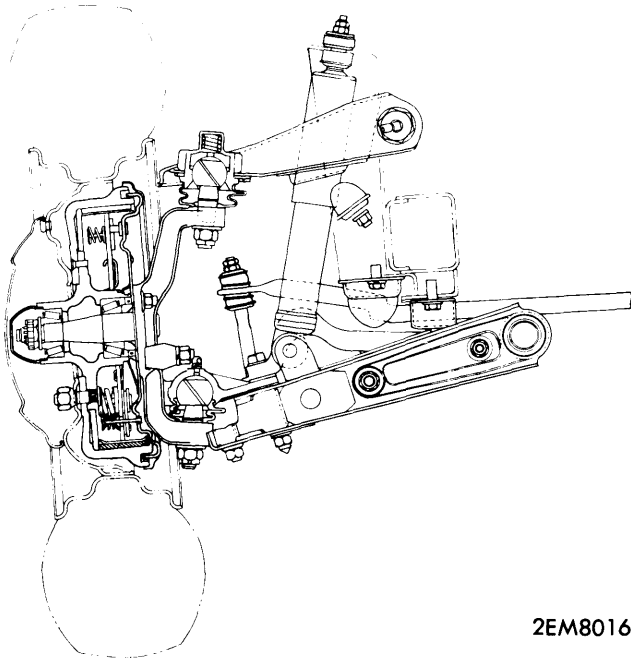

LUV FRONT SUSPENSION

ADJUSTMENT

WHEEL ALIGNMENT SPECIFICATIONS & PROCEDURES

See *Wheel Alignment Specifications & Procedures* in *WHEEL ALIGNMENT* Section.

WHEEL BEARING ADJUSTMENT

See *Wheel Bearing Adjustment* in *WHEEL ALIGNMENT* Section.

BALL JOINT CHECKING

See *Ball Joint Checking* in *WHEEL ALIGNMENT* Section.

REMOVAL & INSTALLATION

► **INSTALLATION CAUTION** — Fasteners (bushings, washers, bolts and nuts) referred to in all installation procedures, are important attaching parts. Failure of these parts could adversely affect the performance of all suspension components. If necessary that fasteners be replaced, replace with same part number or one of equivalent quality and design. Torque specifications must also be used to insure proper tightening of fasteners.

SHOCK ABSORBER

Removal — Raise vehicle. Hold shock absorber upper stem with a wrench and remove retaining nut, retainer and rubber grommet. Remove lower shock absorber pivot bolt from lower control arm and remove shock absorber.

Installation — Check shock absorber and replace if necessary. Fully extend shock absorber, place lower retainer and grommet on stem and slide shock absorber into position. Install upper grommet and retainer on stem and tighten nut to specification. Slide bolt thru lower shock absorber mount and shock absorber. Tighten bolt to specification and lower vehicle.

LOWER CONTROL ARM STRUT BAR

Removal — Raise vehicle and remove double nuts, washers and rubber bushings from front side of strut bar. Remove two bolts holding strut bar to lower control arm and remove strut bar.

Installation — Place washer and bushing on strut bar and slide rod thru frame bracket. Place second set of washers and bushings on end thru bracket and start on one nut but do not tighten. Bolt other end of strut to lower control arm and tighten to specification. Lower vehicle and tighten nut left loose to specification, install second nut and tighten to specification.

STABILIZER BAR

Removal — Raise vehicle and disconnect stabilizer bar from lower control arm. Remove brackets holding bar to frame and remove bar. Remove link bolt, spacers and rubber grommets from lower control arm or stabilizer bar. Inspect all parts for wear or damage and replace if necessary.

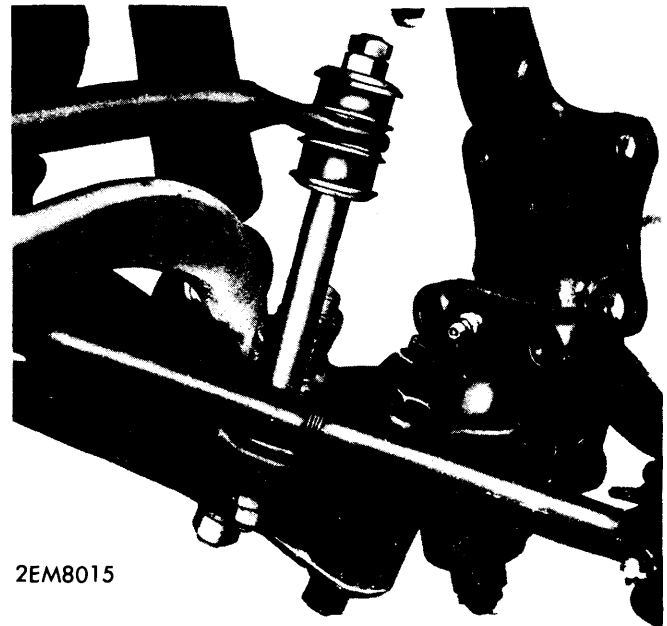

STABILIZER LINK BOLT
COMPONENT ARRANGEMENT

Installation — Bolt brackets to frame over rubber bushings installed over stabilizer bar but do not tighten. Connect link bolts to lower control arm, making sure washers are installed in correct position. Connect link bolts to stabilizer, and tighten to specification. Tighten bolts left loose to specification.

Front Suspension

1972-73 CHEVROLET LUV PICKUP (Cont.)

UPPER CONTROL ARM & BALL JOINT

Removal — Raise vehicle and place safety stands under lower control arm. Remove tire and wheel. Remove upper ball joint cotter pin and nut. Disconnect spindle from upper control arm. **CAUTION** — Do not let spindle and brake assembly hang from brake flex line, wire assembly to frame. Remove dust cover from valance and remove two bolts holding upper control arm to bracket. Remove control arm from vehicle. Note the position and number of shims to keep correct caster and camber when installing control arm. If the pivot shafts or bushings are to be removed, alternately loosen bushing nuts from pivot shaft and remove shaft from control arm. Check control arm and pivot shaft for cracks or distortion. Replace both pivot shaft and bushings if either are found defective. Replace rubber boots if necessary. Ball joint and control arm are a complete assembly. If ball joint needs replacing, entire control arm must be replaced.

Installation — Install boots on upper control arm pivot shaft. Pack inside of bushings with molybdenum disulfide grease and alternately screw right and left bushings into pivot shaft. Use a suitable tool to space pivot shaft when tightening bushings. Avoid getting grease on outer bushing face. Tighten bushings to specifications. Install grease fittings and grease all parts thru fittings. Place ball joint stud thru spindle. Install castellated nut and tighten to specifications. Install new cotter pin, if it does not align, tighten nut just enough for cotter pin to slide in. **NOTE** — Do not loosen nut to allow cotter pin to be installed. Install upper control arm to chassis frame, making sure shims equal in thickness to those that were removed, are installed. Tighten bolts to specifications. **NOTE** — For better pivot shaft to frame retention, tighten thinner shim packs first. Install dust cover, tire and wheel and lower vehicle.

TORSION BAR

Removal — Raise vehicle and place safety stands under front of vehicle. Remove height control arm adjusting nut and mark position of torsion bar with height control arm. Mark position of torsion bar with lower control arm and remove torsion bar.

Installation — Thoroughly grease both ends of torsion bar. Raise lower control arm with a jack to bring rubber bumper in contact with control arm and insert torsion bar into marked position of control arm. Place height control arm in marked position so that it reached adjusting bolt. Install new cotter pin and screw in adjusting bolt. Check riding height as previously outlined.

LOWER CONTROL ARM & BALL JOINT

Removal — Raise vehicle and place safety stand under frame. Remove tire and wheel. Remove strut bar, torsion bar and disconnect stabilizer bar as previously outlined. Disconnect lower end of shock absorber. Remove cotter pin and nut retaining lower ball joint to spindle. Remove lower control arm retaining nuts and remove control arm. Ball joint can be removed with control arm either installed or out of vehicle, by removing two bolts retaining ball joint to control arm.

Installation — Check all parts for distortion, cracking or excessive wear. If ball joint was removed, install ball joint in lower control arm and tighten bolts to specification. Bolt lower control arm to chassis and tighten to specification. Place ball joint stud in spindle, tighten nut to specification, and install new cotter pin. **NOTE** — Do not loosen nut to allow cotter pin to be installed. Install torsion bar, strut bar and stabilizer bar as previously outlined. Install tire and wheel and lower vehicle.

LOWER CONTROL ARM BUSHING

Removal — Raise vehicle and remove tire and wheel. Remove torsion bar as previously outlined. Remove lower control arm bolts and using a wood block, block control arm away from crossmember. Using suitable bushing remover tool assembly (J-21058-1, J-21058-7, J-21474-36, J-21058-6 and J-21474-4 tools), press bushing out of frame crossmember. **CAUTION** — Do not use impact tools for removal or installation of bushing as it may cause distortion of crossmember.

2EM8018

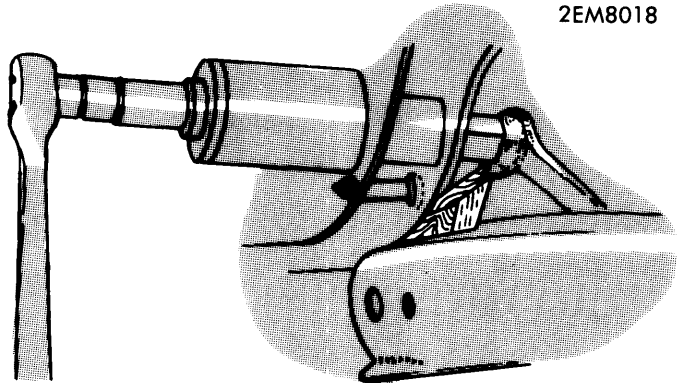

LOWER CONTROL ARM BUSHING REMOVAL

Installation — Using suitable bushing installer tool assembly (J-21058-7, J-21474-4 and J-21474-2 tools), press bushing in crossmember until it is centered. Remove tool assembly and install lower control arm and tighten bolts to specification. Install tire and wheel and lower vehicle.

2EM8017

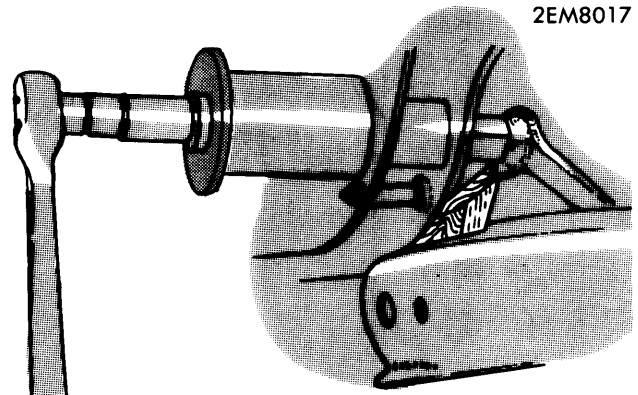

LOWER CONTROL ARM BUSHING INSTALLATION

TIGHTENING SPECIFICATIONS

Application	Ft. Lbs. (mkg)
Upper & Lower Ball Joint Stud	75 (10.4)
Ball Joint-to-Lower Arm	45 (6.2)
Ball Joint-to-Upper Arm	45 (6.2)
Upper Shock Absorber Mount	18 (2.5)
Lower Shock Absorber Mount	45 (6.2)
Upper Arm Pivot Shaft Bushings	220 (30)
Lower Control Arm-to-Crossmember	55 (7.6)
Upper Control Arm-to-Frame	130 (18)
Strut Bar-to-Frame	
Nut	15 (2.1)
Lock Nut	45 (6.2)
Strut Bar-to-Lower Control Arm	45 (6.2)
Stabilizer Bar	
Nut	7 (1)
Lock Nut	18 (2.5)