

Front Suspension

1971-73 DODGE COLT

Colt (1971-73)

REMOVAL & INSTALLATION

DESCRIPTION

Strut type suspension consisting of a vertically mounted strut assembly, lower control arm and a stabilizer bar. Strut assembly is mounted at top to fender panel by means of a thrust bearing. Strut assembly mounts at bottom to a steering arm which pivots on lower control arm by means of a ball joint. Strut assembly consists of a shock absorber built into strut outer tube; a coil spring is mounted on outside of strut tube; wheel spindle is integral with bottom of strut tube. Stabilizer bar is mounted to front chassis members and at ends to lower control arms.

ADJUSTMENT

WHEEL ALIGNMENT SPECIFICATIONS & PROCEDURES

See *Wheel Alignment Specifications & Procedures* in *WHEEL ALIGNMENT* Section.

WHEEL BEARING ADJUSTMENT

See *Wheel Bearing Adjustment* in *WHEEL ALIGNMENT* Section.

BALL JOINT CHECKING

See *Ball Joint Checking* in *WHEEL ALIGNMENT* Section.

STABILIZER BAR

Removal — Remove bolts retaining stabilizer bar brackets to front chassis members and disconnect link bolts retaining stabilizer bar ends to lower control arms. Remove stabilizer bar from vehicle.

Installation — Reverse removal procedure for installation. Tighten all bolts and nuts to specifications.

LOWER CONTROL ARM

Removal — Raise vehicle and place safety stands under chassis members. Remove tire and wheel. Disconnect stabilizer bar from lower control arm. Remove three bolts retaining strut assembly to steering arm. Remove nut from ball joint stud and using a suitable puller (CT-1104), separate steering arm from ball joint. Remove bolts retaining control arm pivot shaft to crossmember and remove control arm from vehicle.

Disassembly — Remove bolts and washers from both ends of pivot shaft. Using a suitable adapter, press pivot shaft along with rear bushing out of control arm. Remove rubber stopper and press out front bushing. Remove cover over ball joint stud by prying around edges with a screwdriver. Using a suitable adapter, press ball joint out of control arm.

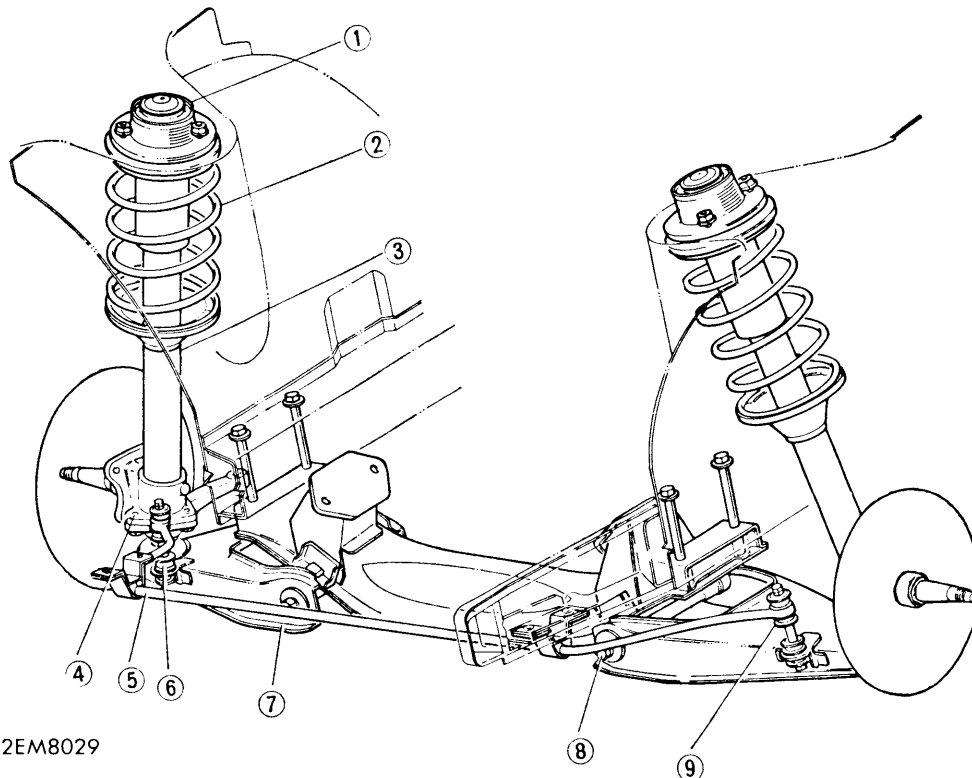

2EM8029

- | | |
|-----------------------------|--------------------------|
| 1 — Thrust Bearing Assembly | 6 — Ball Joint |
| 2 — Coil Spring | 7 — Lower Control Arm |
| 3 — Strut Tube | 8 — Pivot Shaft |
| 4 — Wheel Spindle | 9 — Stabilizer Link Bolt |
| 5 — Stabilizer Bar | |

COLT FRONT SUSPENSION

1971-73 DODGE COLT (Cont.)

Assembly — Bushings are not reusable once they have been removed and must be replaced. Check pivot shaft, ball joint and control arm for wear or distortion. Using a suitable adapter, press front bushing along with pivot shaft into control arm. Install a suitable spreader (CT-1114B), between rear branches of control arm and press in rear bushing. Install pivot shaft bolts and new washers but do not tighten to specification until weight of vehicle is on front wheels. Using a suitable adapter, press ball joint into control arm. Ball joint cover must be replaced when removed. Fill with a suitable grease and using a suitable adapter, press cover over ball joint.

STRUT ASSEMBLY

Removal — Raise vehicle and place safety stands under chassis members. Disconnect strut assembly from lower control arm as previously outlined. Remove brake caliper and hub. Remove dust cover and disc brake adapter. Remove three bolts retaining strut assembly to fender panel and remove strut assembly from vehicle.

Disassembly — Secure strut assembly in vise and remove small dust cover in middle of thrust bearing assembly. Compress spring using a suitable spring compressor (CT-1105) and remove nut retaining thrust bearing. Remove thrust bearing, coil spring, upper spring seat and rubber bumper. Hold strut assembly vertical in vise and using a suitable wrench (CT-1112), remove shock absorber seal. Push piston rod to lowest position and drain oil. Remove O-ring from top of strut tube and carefully draw piston rod assembly and guide up and out of strut tube. Remove guide from piston rod and rod from cylinder.

Assembly — Thoroughly clean all components and check for wear or distortion. Coat piston rod with shock absorber oil and install in cylinder. Carefully insert cylinder and piston rod in strut tube. Push piston rod to bottom of stroke and fill cylinder with 20.7 cu. in. (160 cc) of suitable shock absorber oil. Slowly move piston rod up and down until air is removed from cylinder. Install guide over cylinder and push down until it contacts upper edge of cylinder. Install O-ring between guide and strut tube. *NOTE — Always use new O-ring when removed.* Using a suitable seal guide (CT-1111B), slide shock absorber seal over piston rod and tighten until edge of seal nut touches strut tube. *NOTE — Always use new seal when removed.* Compress spring and install over strut tube. Pull piston rod to end of travel and slide on rubber bumper. Install upper spring seat, thrust bearing and nut and tighten temporarily. Make sure spring is properly seated in spring seats and release compressing tool. Using a suitable holding tool (CT-1112), hold upper spring seat and tighten piston rod nut to specification.

Installation — Reverse removal procedure for installation. Tighten all bolts and nuts to specifications.

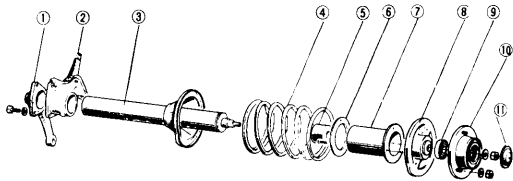

2EM8030

- | | |
|----------------------|-----------------------------|
| 1 — Steering Arm | 7 — Dust Cover |
| 2 — Wheel Spindle | 8 — Upper Spring Seat |
| 3 — Strut Tube | 9 — Thrust Bearing |
| 4 — Coil Spring | 10 — Thrust Bearing Housing |
| 5 — Rubber Bumper | 11 — Dust Cover |
| 6 — Dust Cover Plate | |

STRUT ASSEMBLY COMPONENTS

TIGHTENING SPECIFICATIONS

Application	Ft. Lbs. (mkg)
Pivot Shaft-to-Crossmember Bolts	54 (7.5)
Ball Joint Stud Nut.....	35 (4.8)
Strut Assembly-to-Fender Panel Nuts	9 (1.2)
Strut Assembly-to-Steering Arm Bolts.....	33 (4.6)
Stabilizer Bar Brackets.....	9 (1.2)
Piston Rod Nut.....	33 (4.6)
Pivot Shaft End Bolts.....	44 (6.1)