

# Wheel Alignment

## 1963-73 SAAB SPECIFICATIONS & ADJUSTMENTS

### TIRE INFLATION (COLD)

Before attempting to check or adjust wheel alignment, ensure that tires are properly inflated.

#### Tire Pressure Specifications

Model Application	Front	Rear
95 & 96.....	24.....	24
99.....	24.....	27
Monte Carlo		
Standard Tires.....	21.....	20
Radial Tires.....	20.....	18
Sonnett Exc. III.....	21.....	20
Sonnett III.....	25.....	22

### CASTER

**All Models (1963-73)** — To adjust caster, add or remove shims under bearing brackets of the upper control arms. Changing shims from front bracket to rear bracket increases caster. Moving shims from rear to front decreases caster. **NOTE** — The same thickness of shims removed from one bracket must be placed under other bracket. Change in caster adjustment affects camber. Check camber to specifications.

### CAMBER

**All Models (1963-73)** — To adjust camber, add or remove shims under bearing brackets of the upper control arms. Increasing shims under both brackets reduces camber and decreasing shims under both brackets increases camber. **NOTE** — Always add or remove same thickness of shims at front and rear brackets. Change in camber adjustment affects caster. Recheck caster to specifications.

### TOE-IN

**All Models (1963-73)** — Position front wheels in straight ahead position. Loosen tie rod lock nut on outer end of tie rod. Turn tie rod to set toe-in to specifications. Tighten lock nuts.

**NOTE** — After adjustment of toe-in, measurement A (see illustration) of tie rod must not exceed 1.6" (with key grip) or 1.2" (without key grip). For tie rods opposite to each other the difference between the measurements A must not exceed .08".

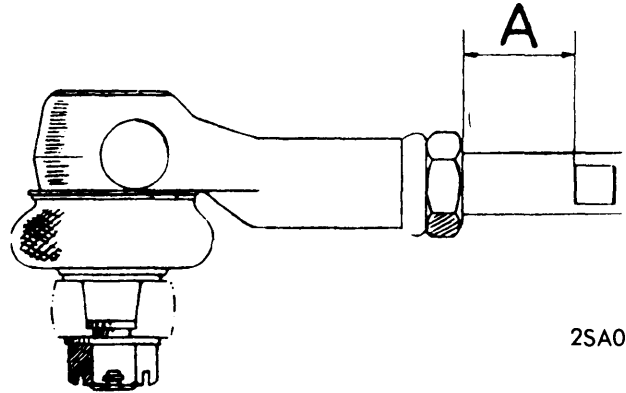

2SA01  
CHECKING LENGTH OF TIE ROD WITH KEY GRIP

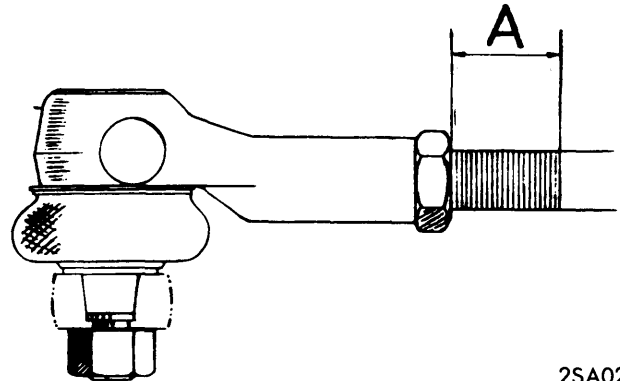

2SA02  
CHECKING LENGTH OF TIE ROD WITHOUT KEY GRIP

WHEEL ALIGNMENT SPECIFICATIONS					
<b>R</b> — Right <b>F</b> — Front <b>Rr</b> — Rear <b>L</b> — Left <b>Man</b> — Man Steering <b>Pwr</b> — Power Steering	Caster (Degrees)	Camber (Degrees)	Toe-In (Inches)	Toe-Out On Turns	
				Inner	Outer
<b>1963-72</b>					
Sonett	2° ± ½°	0 ± ¼°	.04 ± .04	.....	.....
99	1 ¼° ± 1 ¼°	¾° ± ¼°	0 ± .04	.....	.....
All Others	2° ± ½°	¾° ± ¼°	.08 ± .04	.....	.....
<b>1973</b>					
Sonett 97	2° ± ½°	0 ± ¼°	.04 ± .04	22 ½°	20°
Saab 99	1° ± ½°	½° ± ½°	0 ± .04	21 ½°	20°
Saab 95 & 96	2° ± ½°	¾° ± ¼°	.08 ± .04	22 ½°	20°