

1963-73 MGB & MGB/GT

MGB & MGB/GT (1963-73)

DESCRIPTION

MGB brake system is a Lockheed type. Brake system consists of a master cylinder (tandem type after 1968), self-adjusting disc brakes, manually adjusted leading-trailing drum rear brakes, and a lever operated handbrake (located between seats). Front brakes are of the rotating disc and rigid mounted caliper type. Each caliper carries two friction pad assemblies between the rotating disc. Rear brakes are internal-expanding shoe and drum type. Rear brakes are operated by a single wheel cylinder which is hydraulically actuated by a foot pedal and mechanically actuated by a handbrake. Later model vehicles are equipped with a brake failure switch assembly.

ADJUSTMENT

DISC BRAKES

Disc brakes are self-adjusting, therefore no adjustment in service is required.

DRUM BRAKES

Raise and support rear of vehicle, and fully release parking brake. Turn shoe adjuster clockwise until wheel is locked. Back off adjuster one serration. Wheel should now rotate without binding.

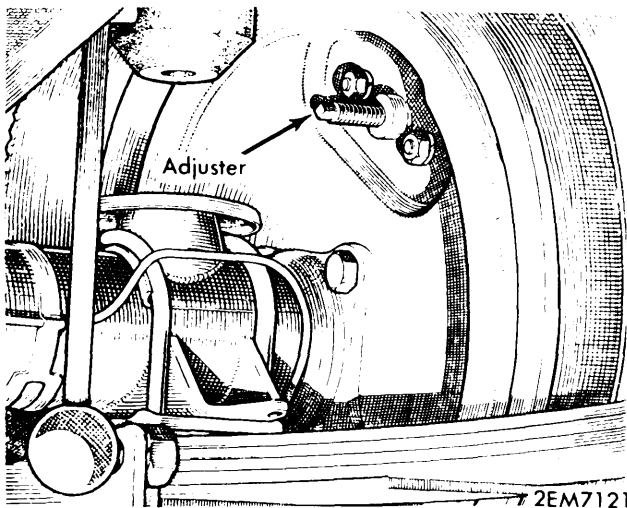

BRAKE ADJUSTMENT POINT

PARKING BRAKE

With service brakes properly adjusted, check for excessive parking brake cable stretch. Turn brass cable adjuster nut until total parking brake lever travel required to fully set parking brake is three to four serrations.

BLEEDING SYSTEM

The following procedure should be observed when initially priming or bleeding hydraulic system: Attach a bleed tube to bleed screw on left side rear wheel cylinder, submerge free end

of tube into a half-full container of brake fluid. Loosen bleed screw and slowly depress pedal its full stroke allowing pedal to return unassisted. Repeat this procedure with slight pauses, until bubbles stop. Carry out operation on remaining wheels.

REMOVAL & INSTALLATION

LINING REPLACEMENT (DISC BRAKES)

Removal – Raise vehicle and remove tire and wheel. Depress pad retaining springs and remove cotter pins with retaining springs. Carefully lift pads out of caliper. Measure pad lining and replace if lining is worn to .063".

Installation – Before inserting disc pads, clean any foreign material from piston head and caliper cavity. Using suitable clamp, seat piston in cylinder bore. *NOTE* – During this operation fluid level will rise. Ensure machined portion of piston face is correctly positioned at inner end of caliper. Insert friction pads, reposition retaining springs and fit cotter pins. Check that pads have some degree of movement in caliper. It is acceptable to file high spots from friction pads if necessary. Pump brake pedal several times to readjust pistons.

LINING REPLACEMENT (DRUM BRAKES)

Removal – Raise vehicle and remove tire and wheel. Loosen brake shoe adjuster and remove brake drum. Depress each shoe mounting spring washer and turn to release from anchor brackets on backing plate. Pull trailing shoe against load of return springs and disengage at each end. After releasing, leading shoe will be free. If necessary, wheel cylinder and handbrake mechanism can now be removed.

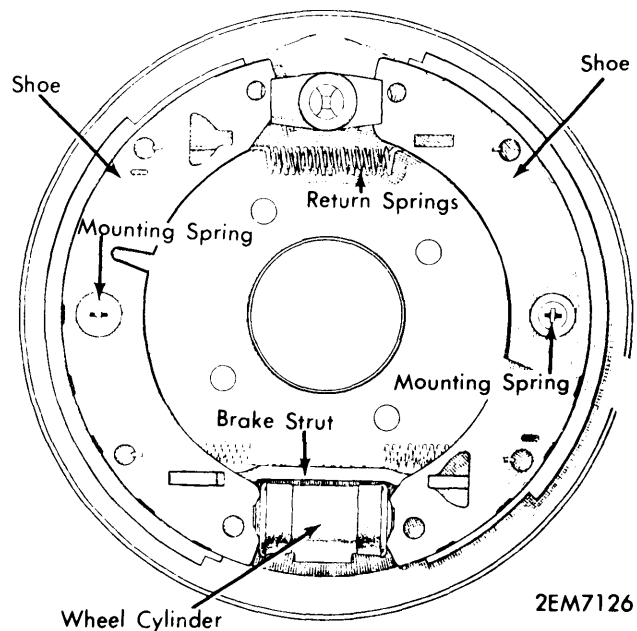

DRUM BRAKE ASSEMBLY

Installation – To install, reverse removal procedure, noting the following: Return springs must be mounted on backing plate side of shoes as shown in illustration. Ensure adjuster mechanism is in retracted position before reinstalling brake drum. If wheel cylinder was removed, bleed hydraulic system.

1963-73 MGB & MGB/GT (Cont.)

BRAKE CALIPER

Removal — Raise vehicle and remove tire, wheel and friction pads. Drain fluid through bleed screw. Disconnect fluid hoses on mounting half of caliper and plug end of hose. Bend locking ears and withdraw mounting bolts. Lift off caliper.

Installation — To install, reverse removal procedure noting the following: torque mounting bolts to 40-45 ft. lbs. and bleed hydraulic system.

MASTER CYLINDER (SINGLE)

Removal — Remove screws mounting brake and clutch master cylinder cover. Drain fluid from reservoir. Remove cotter key, washer and clevis pin from push rod and disengage brake pedal lever. Disconnect pipe from master cylinder and plug opening. Withdraw mounting bolts and detach cylinder from box assembly.

Installation — To install, reverse removal procedure.

MASTER CYLINDER (TANDEM)

Removal — 1) Remove master and clutch cylinder cover plate. Drain fluid from both cylinders. After disconnecting hydraulic lines plug openings. Remove cotter pin and clevis pin from push rod and disconnect pedal lever.

2) Disengage return springs. Remove lower left side instrument panel face. Unscrew bolts securing pedal box to toe plate. Remove nut retaining pedal pivot bolt, withdraw bolt, center spacer and temporarily refit bolt. Unbolt pedal box from firewall and remove complete with master cylinders and pedals.

Installation — To install, reverse removal procedure noting the following: Bleed clutch and brake hydraulic systems. If necessary, readjust service brakes.

POWER BRAKE UNIT

Removal — Disconnect the battery, and remove brake unit-to-mounting bracket attaching bolts. Remove vacuum hose-to-bracket attaching hardware. Disconnect hydraulic lines at

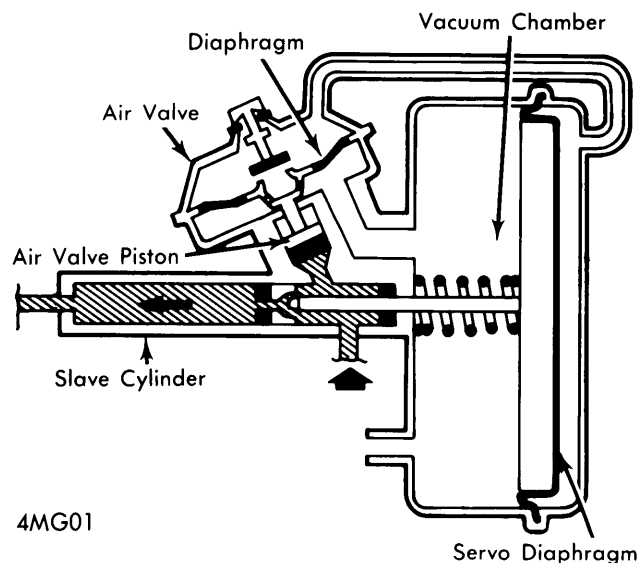

4MG01

POWER BRAKE UNIT

master cylinder. From inside vehicle, remove power brake unit attaching bolts, then remove brake unit from vehicle.

Installation — To install, reverse removal procedure, and bleed hydraulic system.

OVERHAUL

BRAKE CALIPER

Disassembly — 1) Remove brake caliper, leaving inlet hose connected. Clamp piston in mounting half of caliper and gently apply service brakes. This procedure will force rim half piston out enough to be removed by hand.

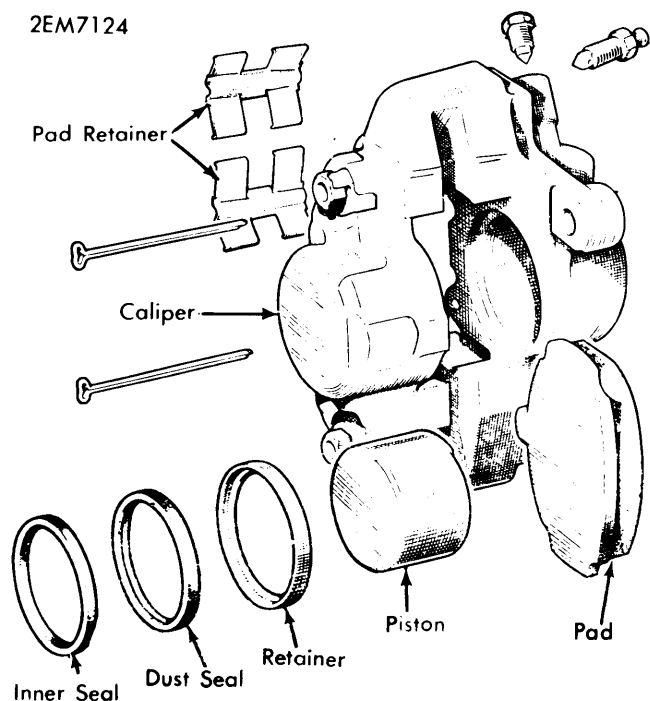

BRAKE CALIPER

2) Using a blunt instrument, remove fluid seal, taking care not to damage bore or retaining groove. To remove dust seal, insert a screwdriver between retainer and seal and gently pry retainer from mouth of caliper bore. **NOTE** — Caliper mounting half must be installed before disassembling rim half. Procedure is same for rim half of caliper.

Reassembly — 1) Coat new seal with brake fluid and ease seal into groove. Loosen bleed screw in rim half one turn. Coat piston with brake fluid and locate piston squarely in cylinder bore with cut-away portion of piston face installed as shown in illustration.

2) Press piston down until 5/16" protrudes from bore. Fit dust seal into retainer. Position seal assembly on extended portion of piston with seal innermost. Seat piston and seal assembly with clamp and retighten bleed screw. Rim half of caliper is reassembled in same manner.

Brakes

1963-73 MGB & MGB/GT (Cont.)

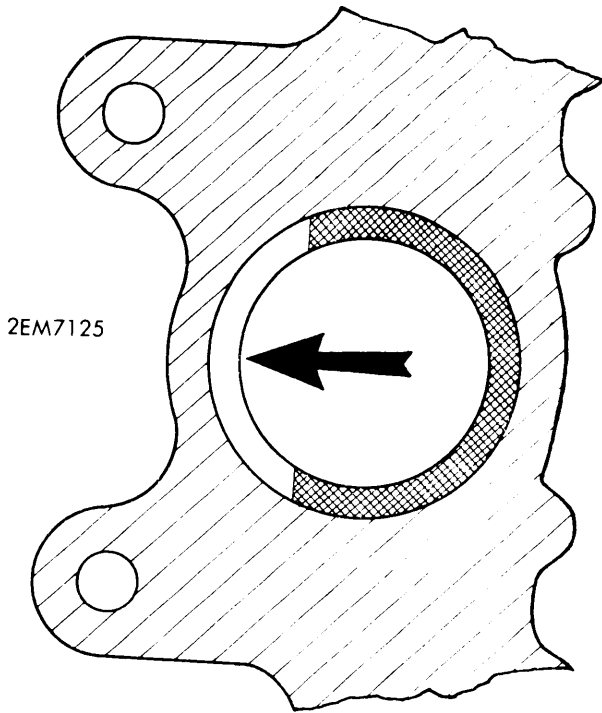

CORRECT PISTON POSITION

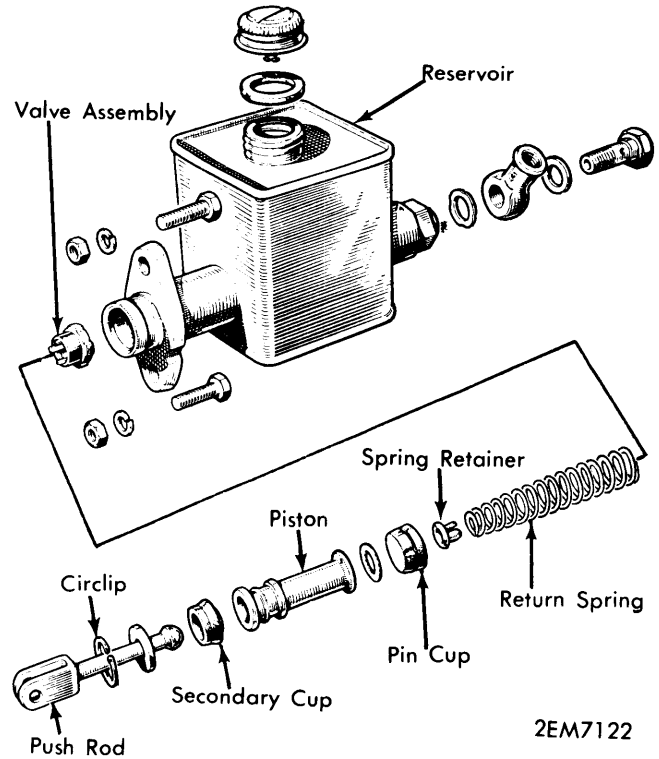

MASTER CYLINDER (SINGLE)

MASTER CYLINDER (SINGLE)

Disassembly – Detach rubber cover from cylinder and remove. Depress push rod to relieve load on circlip then remove circlip and push rod assembly. Withdraw piston, piston

washer, main cup, spring retainer and valve assembly. Remove secondary cup by carefully stretching over end of piston.

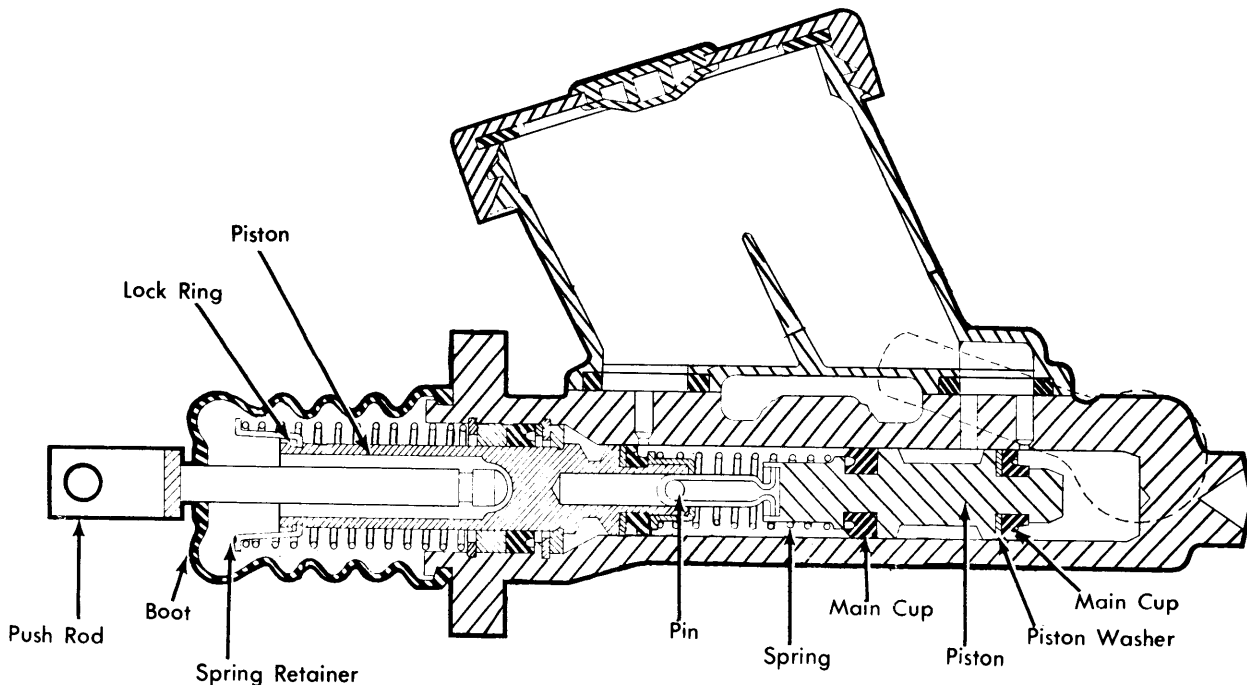

MASTER CYLINDER (TANDEM)

2EM7123

1963-73 MGB & MGB/GT (Cont.)

Cleaning & Inspecting — Clean all components in approved grade brake fluid. Examine all parts for wear or distortion and replace as necessary. *NOTE — It is advisable to replace rubber parts at each overhaul.*

Reassembly — 1) Stretch secondary cup over piston with lip of cup facing head of piston. Work cup around with fingers until it is properly seated. Fit check valve assembly to large end and spring retainer to small end of return spring. Insert spring, check valve first, into cylinder.

2) Insert main cup, lip first, and press down onto spring retainer. Place main cup washer in position, concave face next to main cup, and insert piston. Place push rod in position, push piston down bore and with piston stop washer in bore, refit retaining circlip. Refit dust cover.

MASTER CYLINDER (TANDEM)

Disassembly — Detach rubber boot and withdraw push rod. Grip cylinder in vise and compress return spring removing the

lock ring from its groove in primary piston. Using suitable tool (18G-1112), remove inner circlip. Withdraw primary and secondary piston assembly complete with stop washer. Compress spring separating the two pistons and drive out roll pin retaining piston link. Note position of cups and remove cups and washers from pistons. From cylinder body remove, reservoir, front brake pipe connection adaptor, and withdraw springs and trap valves from connecting ports.

Cleaning & Inspecting — Clean all parts in approved grade brake fluid. Inspect all components for damage and replace as necessary. *NOTE — It is advisable to replace rubber parts during each overhaul.*

Reassembly — Lightly coat all components with brake fluid. Locate piston washers on head of secondary piston: convex surface first. Carefully ease secondary main cup, lip last, over end of piston. Primary piston is installed in same manner. After reassembling primary piston, reverse disassembly procedures for remaining components.