

1963-73 BMW 4 CYLINDER

1600 (1966-71)
 1600-2 (1966-71)
 1800 (1963-68)
 1800 Ti (1963-66)
 2000 (1966-69)
 2000 Ti & Tilux (1966-68)
 2000 CS & CA (1966-67)
 2002 (1968-73)
 2002 Ti (1967-72)
 2002 Tii (1972-73)

DESCRIPTION

Brakes on all models consist of ATE fixed caliper front disc brakes and leading-trailing shoe rear drum brakes. Disc calipers are either two or four piston units. All vehicles from 1970 onward, use tandem piston master cylinders. Hand brake system is operated by lever and cable, and attached to rear brake shoes.

ADJUSTMENT

FRONT DISC BRAKE PADS

Front disc brakes are self-adjusting, therefore, no adjustment in service is required.

REAR DRUM BRAKE SHOES

Raise and support rear of vehicle and release parking brake. Using an offset wrench (BMW 6038), tighten eccentric adjustment nuts while rotating wheel until wheel locks. Loosen adjusting nuts $\frac{1}{8}$ turn or until wheel is just free to turn.

PARKING BRAKE

With rear brakes properly adjusted, pull back rubber boot on parking brake lever and loosen lock nuts. Pull brake lever up to fifth ratchet stop and check for braking action at rear wheels. If adjustment is required, tighten adjusting nuts until rear wheels are locked. Tighten lock nuts and ensure wheels turn freely with parking brake lever released.

HYDRAULIC SYSTEM BLEEDING

NOTE — Manufacturer recommends replacement of brake fluid in entire system once a year to avoid moisture build-up. Attach a pressure bleeder to master cylinder reservoir. **NOTE** — DO NOT exceed 29 psi. Raise vehicle and remove front wheels. Attach a bleeder hose to bleeder screw and immerse opposite end of hose into a container of brake fluid. Open bleeder screw, allow all air to escape, then close bleeder screw. Continue operation until all air has been bled from system. **NOTE** — On front disc brakes, bleed lower inboard screw before bleeding lower outboard screw.

REMOVAL & INSTALLATION

FRONT DISC BRAKE PADS

Removal — Raise and support front of vehicle and remove wheels. Drive retaining pins out toward center of vehicle and remove cross spring. Using a suitable pulling tool (ATE 3.914-1400.2), remove brake pads. If pads are to be reinstalled, mark for reassembly reference. **NOTE** — Pads are not interchangeable.

Installation — **NOTE** — Replacement of disc pads should be done in complete sets only. Using a cylinder brush, clean guide surface and support surface in caliper. **NOTE** — DO NOT use oil based solvents. Siphon sufficient fluid from master cylinder reservoir to prevent overflowing, then press pistons to bottom of bores. Install disc pads, cross spring, and retaining pins. Pump brake pedal several times to position pads against rotor.

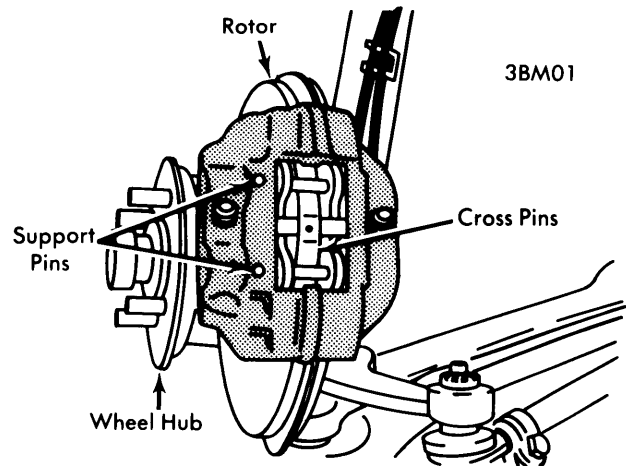

DISC PAD REMOVAL & INSTALLATION

FRONT DISC BRAKE CALIPER

Removal — Raise and support front of vehicle and remove wheels. Disconnect hydraulic lines and plug openings. Remove bolts securing caliper to steering knuckle and remove caliper.

Installation — Reverse removal procedure and note the following: Left and right calipers are not interchangeable. When installed, bleeder screws must face upward. Tighten all bolts and fittings evenly and bleed hydraulic system.

FRONT DISC BRAKE ROTOR

Removal — Remove caliper. **NOTE** — Do not allow caliper to hang from hydraulic line after removal; support out of way. Remove hub grease cap, cotter pin and nut, then remove hub and rotor assembly from axle. Remove Allen bolts and separate brake rotor from wheel hub.

Installation — Install rotor onto wheel hub and tighten bolts securely. Install hub and rotor assembly onto axle, install outer wheel bearing, washer and nut. Adjust wheel bearings and install cotter pin and grease cap. See *Wheel Bearing Adjustment* in *WHEEL ALIGNMENT* Section. Install caliper and bleed hydraulic system if necessary.

REAR BRAKE DRUM

Removal — Remove tire and wheel assembly and loosen eccentric adjusting nuts. Pull drum straight out from axle to remove.

Installation — Install brake drum to axle, install tire and wheel assembly, and adjust brake shoes and parking brake (if required).

1963-73 BMW 4 CYLINDER (Cont.)

REAR BRAKE SHOES

Removal (Exc. 1600-2 Models) — Hoist vehicle, remove rear wheels and brake drums. Detach brake shoes from bottom support, then pull shoes out of wheel cylinder. Disconnect hand brake cable from brake lever. Separate brake shoes by removing return springs.

Removal 1600-2 Models — Release hand brake, hoist vehicle and remove cotter pin from axle castle nut. Remove wheel brake drum and axle flange as a unit. **NOTE** — *If flange will not slide off axle, it will be necessary to remove wheel and drum from flange.*

Installation (All Models) — Reverse removal procedure and adjust brake shoes. See *Drum Brake Adjustment*.

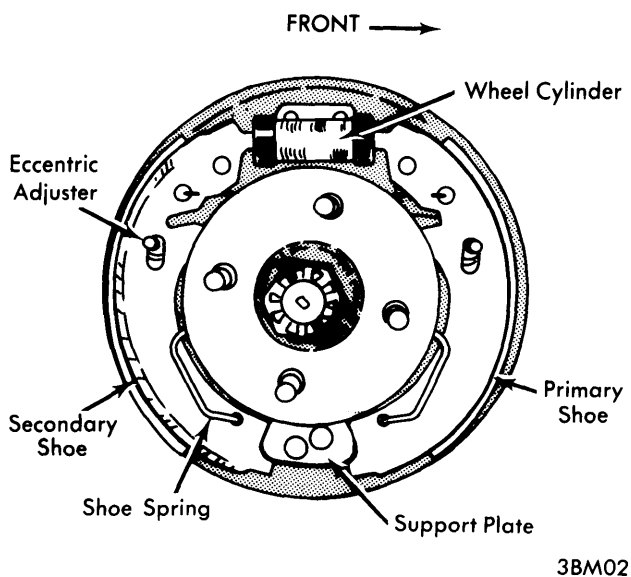

REAR BRAKE ASSEMBLY

REAR BRAKE WHEEL CYLINDER

Removal — With brake drum removed, disconnect hydraulic line, and remove bleeder screw and wheel cylinder attaching bolts. Using an offset wrench (BMW 6038), turn brake shoe eccentric adjusting nuts until shoes are spread out from wheel cylinder as far as possible. Remove wheel cylinder by maneuvering out of backing plate.

Installation — Reverse removal procedure, adjust brake shoes, and bleed hydraulic system.

MASTER CYLINDER

Removal — Siphon fluid as necessary from master cylinder reservoir. If necessary, remove air cleaner assembly. Disconnect hydraulic lines from cylinder, cap all openings, and mark lines for reassembly reference. Remove attaching bolts and separate master cylinder from power unit.

Installation — Reverse removal procedure and note the following: Make sure rubber "O" ring is installed on master cylinder between cylinder and power unit. Check clearance between master cylinder piston and power unit push rod. Clearance should be .020", and is adjusted by removing or installing shims behind head of power unit push rod.

POWER BRAKE UNIT

Removal — With master cylinder removed, disconnect power unit push rod from pedal assembly by removing clevis pin. Disconnect vacuum line from check valve, remove nuts attaching power unit to support, and remove power brake unit.

Installation — Reverse removal procedure, taking care to install rubber "O" ring on master cylinder between cylinder and power unit.

Check Valve Replacement — Vacuum check valve is located in vacuum line at intake manifold. To remove, loosen hose clamps, separate vacuum hoses from valve, and remove valve. To install, position check valve so that arrows or black portions of valve face intake manifold, install vacuum hoses, and install and tighten clamps.

Filter Replacement — With power brake unit removed from vehicle, remove rubber dust boot, retainer, silencer, and filter. To install, reverse removal procedure making sure slots in filter and silencer are offset 180° in relation to one another.

OVERHAUL

FRONT DISC BRAKE CALIPER

Disassembly — With caliper removed from vehicle, remove rubber protective caps, taking care not to damage pistons. Insert a piece of wood in caliper cavity, and remove pistons by applying compressed air to inlet holes of caliper. Using a plastic (or other soft material) tool, remove sealing rings from caliper bores. **NOTE** — *Do not separate caliper halves unless a leak is detected.* To disassemble caliper, remove expansion bolts and separate caliper halves. Remove sealing rings.

Cleaning & Inspection — Clean all parts in alcohol and dry with compressed air. Check cylinder bores, pistons, and flange surfaces for rust, corrosion, or other damage. Replace parts as necessary; do not attempt to machine caliper bores or pistons.

Reassembly — Reassemble caliper with new sealing rings and expansion bolts if halves were separated. Tighten caliper expansion bolts alternately and evenly from inside out. Coat pistons and sealing rings with ATE brake cylinder paste (or equivalent) and install into caliper bores. Install protective caps.

REAR WHEEL CYLINDER

Disassembly — Remove dust caps, then withdraw piston and seal assemblies and spring. Remove bleeder screw. Remove rubber seals from pistons.

Cleaning & Inspection — Clean all parts in alcohol. Check all parts for wear or damage; replace parts as necessary. Make sure that grooves on cylinder body are not corroded.

Reassembly — Coat all parts with ATE brake cylinder paste (or equivalent) and reverse disassembly procedure. **NOTE** — *Manufacturer recommends replacing piston seals whenever cylinder has been disassembled.*

MASTER CYLINDER

Disassembly — Push in on primary piston and remove piston stop screw on top of master cylinder. Remove retaining ring from end of cylinder and withdraw primary piston assembly.

1963-73 BMW 4 CYLINDER (Cont.)

Use compressed air to remove secondary piston assembly from cylinder bore, then remove piston return spring. Disassemble piston assemblies, noting number and position of parts used.

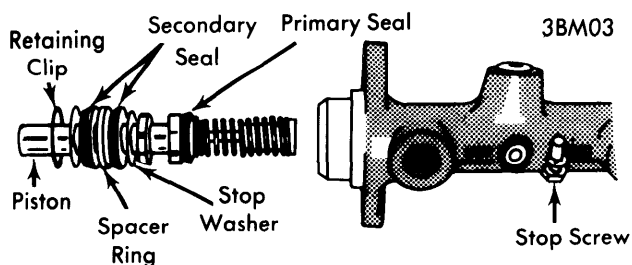

PRIMARY (REAR) PISTON ASSEMBLY

Cleaning & Inspection — Clean all parts in alcohol and check for wear or damage. *NOTE* — Cylinders with surface defects in bores must be replaced; do not overhaul.

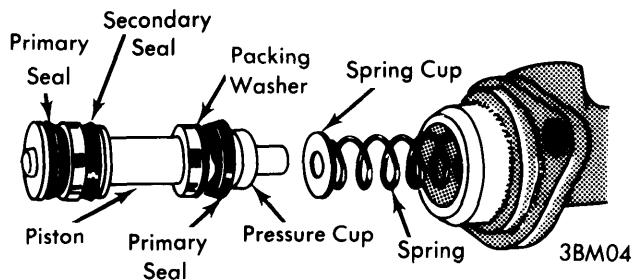

SECONDARY (FRONT) PISTON ASSEMBLY

Reassembly — Reassemble piston assemblies using a thin coating of ATE brake cylinder paste (or equivalent). Install piston assemblies into cylinder bore using a suitable guide sleeve (BMW 6063) to prevent damaging seals. Install secondary piston stop screw, making sure that piston is pushed fully forward before screw is installed and tightened. Install retaining ring in end of master cylinder bore.

TIGHTENING SPECIFICATIONS

Application	Ft. Lbs. (mkg)
Caliper-to-Kingpin Pivot.....	69 (9.5)
Brake Disc-to-Wheel Hub.....	43-48 (6-6.7)
Brake Hose-to-Caliper.....	9-12 (1.3-1.6)
Pre-Pressure Valve.....	14 (1.9)
Wheel Nuts.....	65 (9)
Collar Nut on Brake Line.....	9-12 (1.3-1.6)
Caliper Halves.....	⓪25 (3.4)
Castle Nut-to-Drive Flange.....	217-271 (30-37.5)
Master Cylinder-to-Brake Servo.....	9-11 (1.2-1.5)
Brake Reverse Motion	
Lever At Pivot Mounting.....	33-37 (4.9-5.4)
Brake Mounting-to-Trailing	
Arm (With Loctite).....	43-47 (6-6.7)

⓪ — For models 1600-2, 1602, 1802 and 2002, torque caliper halves to 20-22 ft. lbs. (2.3-2.7 mkg).

For models 2002 TI and 2002 TII, torque caliper halves to 26-34 ft. lbs. (3.7-4.7 mkg).

BRAKE DRUM SPECIFICATIONS

Application	Drum Diameter In. (mm)	Original Diameter In. (mm)	Maximum Refinish Diameter In. (mm)	Discard Diameter In. (mm)
1600 & 1600-2	7.87 (200.0)	7.87 (200.0)	7.91 (201.0)	⓪
All Others	9.84 (250.0)	9.84 (250.0)	9.88 (251.0)	⓪

⓪ — When maximum refinish diameter is exceeded.

BRAKE SYSTEM SPECIFICATIONS

Application	Drum Diam. In. (mm)	Wheel Cylinder Diameter		Master Cylinder Diameter In. (mm)
		Front In. (mm)	Rear In. (mm)	
1600 & 1600-2	7.87 (200.0)	⓪1.34 (34.0)	.687 (17.46)	⓪.812 (20.64)
2002 Ti & Tii	9.84 (250.0)	1.57 (40.0)	.687 (17.46)	.937 (23.81)
All Others	9.05 (230.0)	⓪1.34 (34.0)	⓪.687 (17.46)	⓪.812 (20.64)

⓪ — On single piston models, master cylinder diameter is .75" (19.05 mm).

⓪ — On 2000 models with single piston master cylinders up to chassis No. 1 601 873, diameter is .710" (19.05 mm) and after chassis No. 1 601 873, diameter is .812" (20.64 mm).

⓪ — On 2000 models with single piston master cylinders, diameter is 1.889" (48.0 mm).

⓪ — On 1800 models, rear wheel cylinder diameter is .624" (15.87 mm).

Brakes

1963-73 BMW 4 CYLINDER (Cont.)

DISC BRAKE ROTOR SPECIFICATIONS						
Application	Disc Diameter In. (mm)	Lateral Runout In. (mm)	Parallelism In. (mm)	Original Thickness In. (mm)	Minimum Refinish Thickness In. (mm)	Discard Thickness In. (mm)
1600 & 1600-2	9.45 (240.0)	.004 (.10)	.0008 (.02)	.394 (10.0)	.354 (9.0)	③
2002 Ti & Tii	10.71 (272.0)	.004 (.10)	.0008 (.02)	.499 (12.7)	.461 (11.7)	③
All Others	①10.56 (268.0)	.004 (.10)	.0008 (.02)	④.499 (12.7)	②.461 (11.7)	③

- ① — On 1800 models, diameter is 10.56" (268.0 mm).
 ② — On 1800 models, minimum thickness is .354" (9.0 mm).
 ③ — When rotor is less than refinish thickness.
 ④ — On 1800 models, original thickness is .394" (10.0 mm).