

1971-73 TOYOTA CORONA MARK II & CROWN POWER STEERING

Corona Mark II (1972-73) ①
Crown (1971-72) ②

- ① — Before January 1972, Corona Mark II models used manual steering gear. See *appropriate article in this Section*.
- ② — Before February 1971, Crown models used manual steering gear. See *appropriate article in this Section*.

DESCRIPTION

POWER STEERING PUMP

The power steering pump is a vane type composed of an engine driven eccentric rotor, a fixed ring (having six slotted grooves), and a flow control valve (to regulate maximum oil pressure and amount of oil flow). Slippers are fitted in each slotted groove and are pressed against rotor outside surface by pressure produced in adjoining slots and by spring tension. As rotor rotation increases or decreases the space between rotor and fixed ring changes accordingly to control oil flow.

POWER STEERING GEAR

Power steering gear consists of a mechanism which converts steering wheel torque to cross shaft torque by means of worm and power piston nut, and of a mechanism which detects hydraulic pressure developed by vane pump and controls this pressure in proportion to the steering effort. The worm shaft is separated at the center and power is transmitted from the steering wheel to worm gear through a small diameter torsion bar.

ADJUSTMENTS

BELT TENSION ADJUSTMENT

There should be appropriate indicated deflection at points shown in illustration, when 22 lbs. (10 kg) pressure is applied.

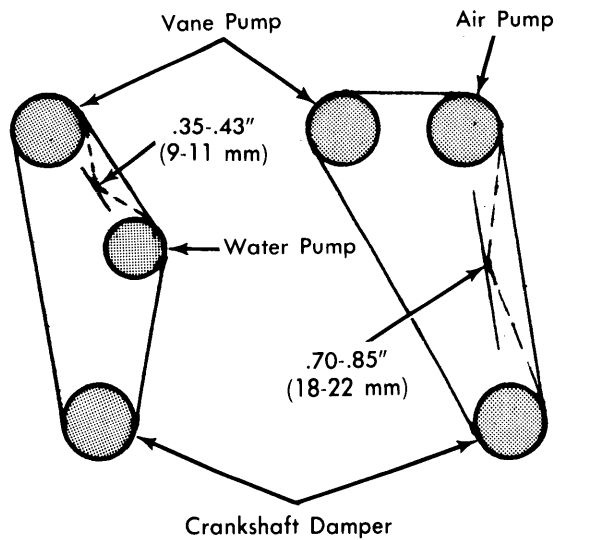

2T0014

MEASURING BELT DEFLECTION

STEERING GEAR AIR REMOVAL

1) Jack up front of vehicle and support with safety stands. Fill fluid to proper level in vane pump reservoir (turn wheels fully in both directions and recheck fluid level).

2) Turn steering wheel fully to one side and turn engine over while fluid level in reservoir is observed. **NOTE** — Do not start engine or run starter for prolonged periods. Repeat procedure with steering wheel turned to other side. Start engine, allow to idle, and turn wheels from side to side two or three times.

3) Remove safety stands and lower vehicle. Again allow engine to idle and turn wheels fully side to side two or three times. When steering wheel is brought to center position and engine stopped, fluid level should not show a rise. If fluid level does rise, there is air still in the system and Step 3 should be repeated.

FLUID REPLACEMENT

1) Raise and support front of vehicle. Disconnect return hose. **NOTE** — Have container on hand as fluid will drain from disconnected hose. Drain fluid from pump by turning engine over (do not start). Drain fluid from steering gear (turn wheel to both sides twice).

2) Refill reservoir with new fluid. Repeat draining procedure, then fill reservoir to specified level.

VANE PUMP ADJUSTMENT

1) Remove upper fan shroud. Connect a suitable pressure gauge to pump outlet. Hold drive belt and remove pump pulley retaining nut. Remove belt and pulley.

2) Extract relief pressure setting bolt and discard. Assemble new relief set bolt: Install relief spring and spring seat into relief valve bore, then install ball. Lubricate and install two new "O" rings on relief pressure set bolt and install into bore. **NOTE** — Leave bolt extending .040" (1 mm) out from rear housing. Do not lock bolt into place until after pressure adjustment.

3) Install pulley and drive belt, tighten pulley retaining nut to specification. Adjust belt tension, as previously described. Adjust relief pressure to 1025-1165 psi. See *Hydraulic Pressure Testing* below. If pressure is not as specified, turn relief valve set bolt to obtain suitable pressure reading (clockwise to increase pressure, counterclockwise to decrease pressure). **NOTE** — A 180° rotation will increase pressure approximately 350 psi. After pressure is set, lock bolt by staking threads.

HYDRAULIC PRESSURE TESTING

1) Disconnect pressure line from steering gear case and mount a pressure gauge in line. Perform Steering Gear Air Removal, as previously described. After warming engine, set to idle speed. Open pressure gauge valve fully and record readings at the time steering wheel is turned completely left and completely right. Suitable pressure reading should be 1067 psi. **NOTE** — Do not hold steering in either extreme position for any length of time as damage may result to vane pump due to rising fluid temperatures. If pressure does not rise to specifications, pump, hoses, or steering gear is defective.

2) Gradually close pressure gauge valve and record pressure. If pressure fails to rise to same specifications as given above, pump is faulty. If less than minimum specification was recorded above during turning check, steering gear is defective. Also, if greater than maximum pressure was recorded during valve closing test, steering gear is faulty. **NOTE** — Test pressure specification is determined with fluid temperature at 167-185°F (75-85°C).

1971-73 TOYOTA CORONA MARK II & CROWN POWER STEERING (Cont.)

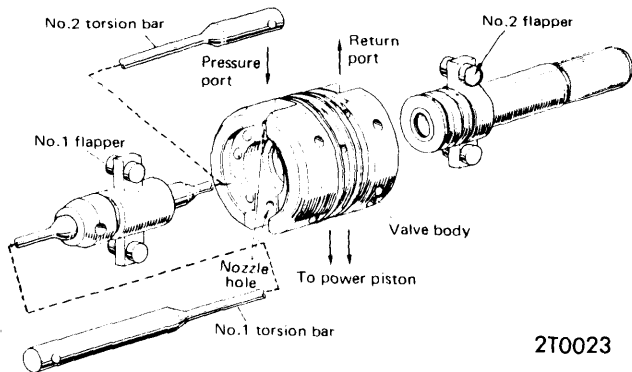

VALVE BODY & FLAPPERS

REMOVAL & INSTALLATION

POWER STEERING PUMP

Removal — Loosen pulley mounting nut before loosening drive belt. Disconnect pressure feed line from pump housing. **NOTE** — Keep disconnected hose at high level to prevent fluid from draining out. Also plug pump housing hose fitting. Disconnect inlet fluid line. Remove pump assembly from mounting bracket and adjusting strap.

Installation — Install in reverse of removal procedures, noting the following: Adjust drive belt tension as previously described, then perform Air Removal procedure.

POWER STEERING GEAR

Removal — Disconnect pressure feed hose and inlet return line from steering gear housing. Remove bolt securing the intermediate shaft to flexible coupling. Unscrew nut from cross shaft. Remove pitman arm, using suitable puller (09610-20011). Unbolt steering gear from frame, then remove gear assembly from vehicle. **NOTE** — Do not loose shims from their mounting positions; they must be retained for replacement.

Installation — Reverse removal procedure, noting the following: Replace mounting shims in original positions. Perform Air Removal procedure, as previously described.

OVERHAUL

POWER STEERING PUMP

Disassembly — 1) **NOTE** — Pump disassembly will be made easier if a suitable holding tool is used (09629-22010). Clamp holding tool in vise and mount pump assembly to tool. Remove front reservoir attaching bolt, then remove both rear reservoir bolts. Detach reservoir by tapping at pump inlet with a plastic hammer.

2) Remove pressure hose union from pump and withdraw flow control valve and compression spring. Unscrew five bolts securing pump housing halves. Remove front housing by holding rotor shaft and fixed ring, then tap front housing off with plastic hammer. Remove nut from rotor shaft. **NOTE** — Bolt which retains front of reservoir is slightly longer than five pump housing bolts.

3) Tap rear housing from fixed ring. **CAUTION** — Do not tap flow control valve. Clamp rear housing and holder in a vise. Remove screw, washer, and snap ring from front of flow control valve. Reinstall screw and grip with pliers to pull flow control spring seat from bore.

4) Remove relief pressure set bolt. **NOTE** — Do not disassemble relief bolt unless pump oil pressure stays low at all times.

5) Disassemble fixed ring and rotor shaft. Pull out slippers, springs, and spring seat. Extract rotor from fixed ring. Remove "O" ring from inner groove of rear housing, then remove rear side plate. Withdraw "O" ring and side plate from front housing.

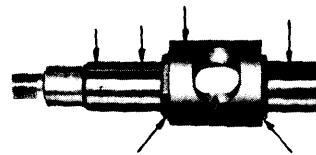

2T0015

ROTOR SHAFT SUB-ASSEMBLY INSPECTION POINTS

Inspection — 1) Clean all disassembled parts in solvent and blow dry. Inspect oil seal lip and bushing sliding surface for wear or damage. Measure shaft for out-of-round at bushing contact surfaces. Ovality must not exceed .0004" (.01 mm). Check rotor outer surface for wear or scoring. Inspect rotor-to-side plate contact surface.

2) Measure overall length of rotor (between end faces) and overall length of fixed ring. If overall length of rotor is more than .002" (.05 mm) shorter than fixed ring overall length, replace with new rotor shaft sub-assembly.

3) Inspect slipper for wear: Measure length and thickness. If thickness is less than .055" (1.5 mm) or if length is less than 1.5717" (39.92 mm), replace entire set.

4) Inspect front and rear housing bushings. Bushing-to-rotor shaft clearance must not exceed .00098" (.025 mm). Inspect internal surface of fixed ring. If worn, scratched, or scored, replace ring. Check front and rear side plates at sliding surfaces. Bushings cannot be replaced separately. Replace entire housing.

5) Measure free length of slipper compression springs. If less than .51" (13 mm), replace individually. If free length varies more than .02" (0.5 mm) between springs, replace entire set.

6) If low control valve is scratched or otherwise damaged, replace it with one having the same production number. Measure compression spring for flow control valve. If free length measures less than 1.77" (47 mm), replace spring. Inspect ball and relief spring. Free length of relief spring must not be less than .531" (13.5 mm). If so, replace spring.

7) Inspect reservoir for leakage. Inspect "S" type oil seal and replace if damaged: Remove with suitable driver (09630-30020). Apply suitable lubricant to lip of seal.

Power Steering

1971-73 TOYOTA CORONA MARK II & CROWN POWER STEERING (Cont.)

Reassembly - 1) NOTE - Replace all "O" rings. Unless otherwise noted, coat all sliding surfaces and "O" rings with power steering fluid. Install "O" ring into spring seat. Insert seat and snap ring into flow control bore. Install snap ring lock plate and screw. Lubricate and install flow control spring and valve. Check operation of valve by pushing into bore with finger. NOTE - Ensure number on flow control valve is the same as that stamped on rear housing (see illustration).

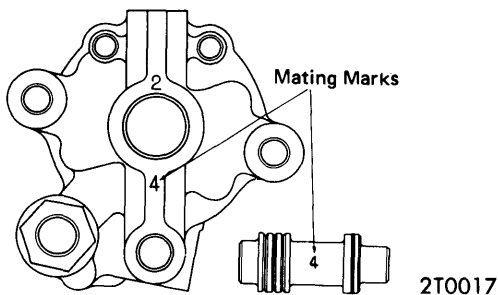

VALVE & HOUSING MATCHING MARKS

2) Install two "O" rings on hose union and screw it into housing. Tighten to specification. Attach side plate to rear housing. Install "O" ring into groove in rear housing. Place fixed ring on rear housing. NOTE - It may be helpful to install two guide

bolts. Tap fixed ring into rear housing. Remove guide bolts. NOTE - Fixed ring, if replaced, must have same stamp number as on rotor shaft.

3) Lubricate and install rotor into rear housing. Assemble spring seat, springs and slipper. Install slipper assembly with notched or open side facing in counterclockwise direction. NOTE - Ensure all slippers face rotor.

4) Install oil seal into front housing. Install lubricated side plate with chamfer facing front housing. Install "O" ring. Install front housing with long ear of housing facing right. Install two guide bolts and tap housing into position. Install "O" rings on five housing bolts and screw into position.

5) Place "O" ring on reservoir outlet and insert it into rear housing. Install "O" ring on long bracket bolt and insert and tighten. Tighten two rear reservoir bolts.

6) Assemble relief pressure set bolt as follows: Install relief spring with spring seat into relief valve bore, then install ball. Install two "O" rings on relief pressure set bolt. Position bolt into valve bore, with bolt extending .040" from rear housing. Do not lock bolt in place at this time.

7) Mount pulley on rotor shaft and measure shaft turning torque with pull scale. Torque should be less than 6.2 lbs. Ensure pulley turns smoothly.

NOTE - Install assembly and make proper adjustments. See Removal & Installation procedure in this article.

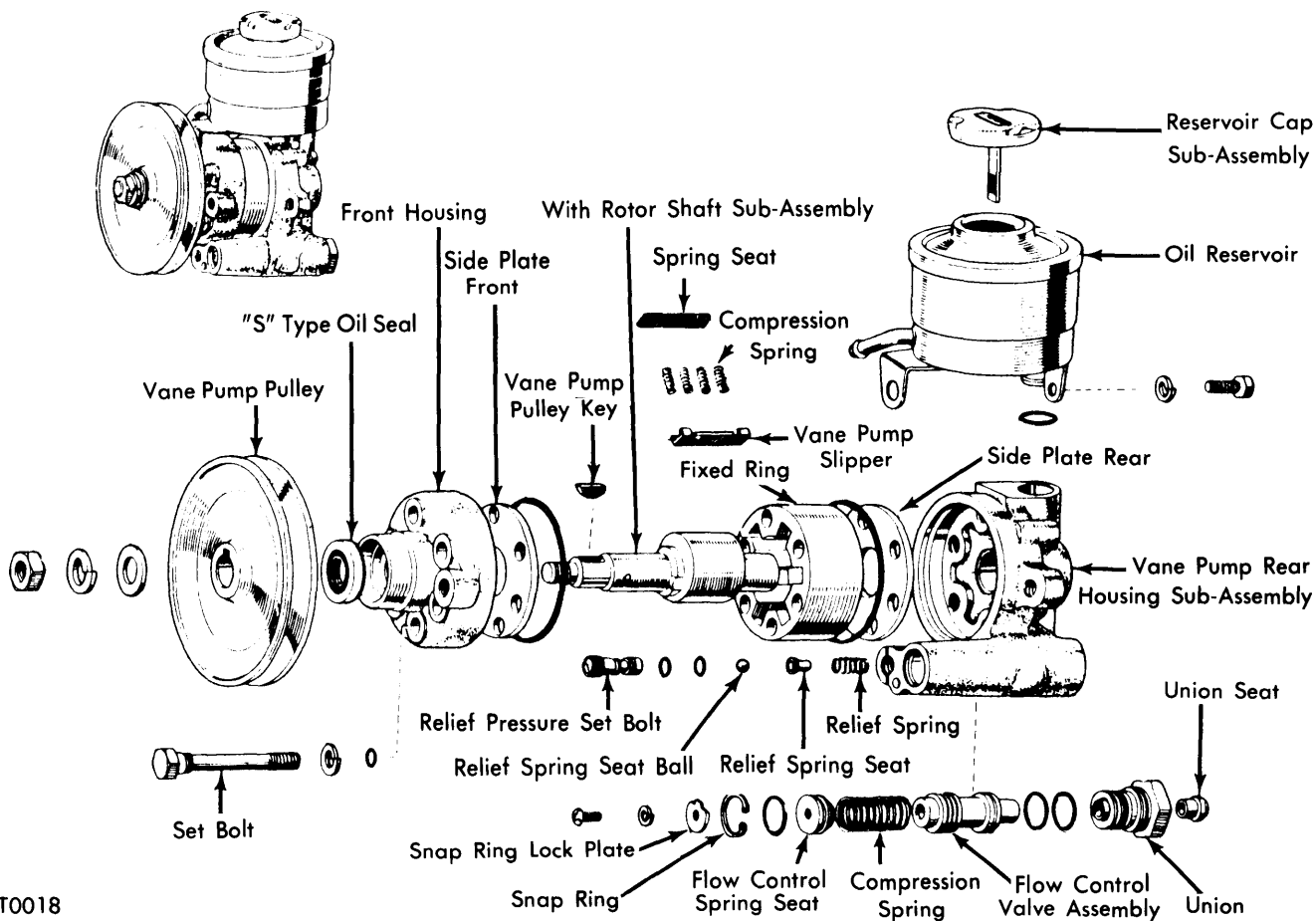

POWER STEERING PUMP ASSEMBLY

1971-73 TOYOTA CORONA MARK II & CROWN POWER STEERING (Cont.)

POWER STEERING GEAR

Disassembly - 1) *NOTE* - To aid in overhaul procedure, bolt steering gear to suitable holding tool (09630-30040). Clamp gear assembly and holding tool in vise. Remove hose union seats and discard. Remove cross shaft end cover retaining bolts. Screw cross shaft adjusting bolt into free end cover from housing. *NOTE* - Cover cross shaft splines with tape to prevent damage to oil seal as shaft is pulled through housing. Loosen end cover until "O" ring is free from gear housing. Lightly tap splined end of cross shaft and remove from housing.

2) Continue to tighten adjusting screw until end cover is released from cross shaft. *CAUTION* - Needle bearing roller will fall out during disassembly, do not lose.

3) Remove bolts attaching gear housing to valve housing. Hold power piston nut with hand and turn worm shaft clockwise until valve assembly lifts up from gear housing. Dismount gear housing from holding tool, then mount valve housing on tool.

4) Check ball clearance by moving power piston nut in lateral direction (see illustration). Take measurement .40" (10 mm) in from end of power piston nut. Lateral deflection limit is .006" (.15 mm). If clearance is exceeded, replace valve assembly with power piston nut.

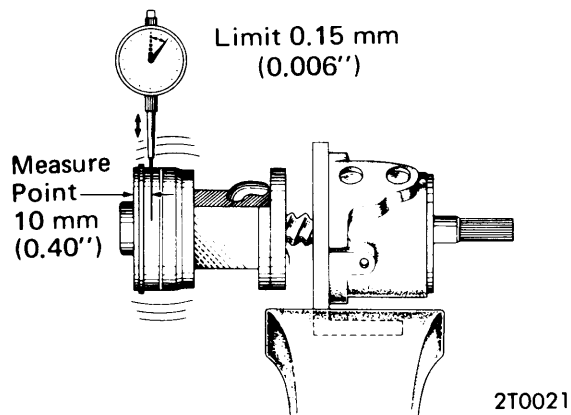

CHECKING BALL CLEARANCE

5) Remove power piston nut by turning worm shaft clockwise. *CAUTION* - Do not lose any of the balls contained in unit. Loosen set screw and remove ball guide. Remove teflon ring and "O" ring. *NOTE* - Do not disassemble end plug.

6) Mount valve assembly on holding tool and clamp in vise. Using suitable tool, remove lock nut. Loosen adjusting plug until its threaded part is visible above valve housing. Remove steering worm sub-assembly. Extract bearing, washer, teflon ring, and "O" ring from valve housing. Then remove seat, spring and spool.

7) Withdraw adjuster plug and "O" ring from steering sub-assembly. Remove washer and bearing. Take out teflon ring, "O" ring, and teflon ring for flapper valve bearing case from valve body. Remove flapper valve bearing case by lightly tapping out with brass drift.

8) Remove gear housing snap ring. Using suitable tool (09308-00010), remove oil seal. Remove teflon ring and "O" ring from inside surface of seal ring case. Pull out seal ring case, using suitable tool (09308-00010). Remove "O" ring from seal ring case.

Inspection - 1) Clean and dry all disassembled components. Unless otherwise mentioned, coat all sliding parts, "O" rings, and teflon rings with power steering fluid upon reassembly. Inspect adjuster plug oil seal and replace if necessary.

2) Determine if any looseness exists in torsion bar pins. Check flapper button for scoring or damage. Inspect worm shaft for peeling or pitting at ball rolling surface. Check power piston nut mesh with cross shaft. Look for damaged tooth surfaces or ball rolling surfaces. If any of these conditions exists, valve assembly must be replaced with power piston nut.

3) Examine valve housing sub-assembly for the following: Defective rollers for bearings, damaged plate washer, marred housing inner surface, or damaged "O" ring.

4) Replace valve housing spool if defective. Measure compression spring free length. If less than .59" (15 mm), replace with new spring.

5) Check all grooves and surfaces of cross shaft and end cover for any defects. Replace as necessary. Using a suitable feeler gauge, check clearance between cross shaft adjusting screw head and cross shaft "T" slot surface. Replace thrust washer with one of suitable thickness if clearance is not within .001-.002" (.03-.05 mm).

6) Gear housing bearings must be replaced if bearing rollers are pitted or peeled. Also replace housing bearings if it was noticed that cross shaft bearing surfaces had been scored or pitted.

Reassembly - 1) Install "O" ring on outside of seal ring case and "O" ring and teflon ring on inside of case. *NOTE* - Teflon ring must be bent into heart shape to assist installation. Use a suitable tool to run-in teflon ring. Apply a thin coat of grease on outer "O" ring, then press case into gear housing. Coat housing oil seal circumference with liquid sealer and drive into housing. Install snap ring. Grease oil seal lip.

2) Drive flapper valve bearing case into worm sub-assembly, using suitable driver (09613-26010). Install teflon ring. Position "O" ring and teflon rings on valve body. *NOTE* - White teflon ring should be in outer grooves and black teflon ring in center groove. Run-in all teflon rings. Install thrust needle roller bearing with larger chamfer on inside diameter facing valve body. Install plate washer with larger chamfer on outside diameter facing valve body. Install teflon ring. Fit "O" ring on adjuster plug and install in worm sub-assembly.

3) Place "O" ring on valve housing perimeter, mount valve housing on holding tool and clamp in vise. Insert spool and spring into housing. Assemble "O" ring onto spring seat and screw spring seat into housing. *NOTE* - Spring seat end should be flush with housing end. Lock spring seat end by staking threads. Insert "O" ring and teflon ring in bottom of housing. Install plate washer followed by thrust needle roller bearing. *NOTE* - Position plate washer with larger chamfered edge facing housing bottom and thrust bearing with smaller chamfer at inside diameter facing housing bottom.

4) Install worm sub-assembly into housing. Screw worm bearing adjuster into housing and adjust to obtain 7.5-12.3 lbs. (measure with pull scale and cord as illustrated). Turn adjuster in 2-3 more turns; there should be no change in preload or excessive binding. Back off adjuster screw 10°, then check for 3.7-6.3 lbs. torque preload. Retighten adjusting screw to gain original specified torque preload. Tighten lock nut to specification.

Power Steering

1971-73 TOYOTA CORONA MARK II & CROWN POWER STEERING (Cont.)

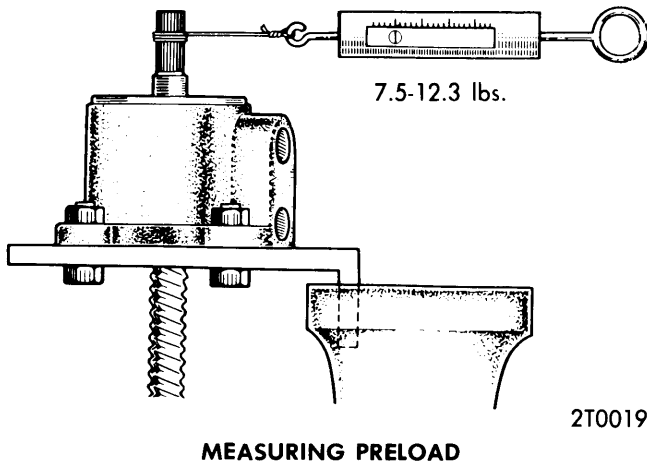

5) Position "O" ring and teflon ring on power piston nut and run them in by hand. Reclamp holding tool so that worm shaft will be in horizontal position. Insert power piston nut over worm shaft until it contacts valve housing end surface. Turn worm shaft until worm shaft ball rolling surface is aligned with power piston ball rolling surface.

6) Using a short pipe, insert balls into power piston nut: Insert pipe in power piston nut hole, place balls in pipe, and turn power piston nut 90° in both directions to assist ball entry.

Place 11 balls into ball guide (coat with grease to prevent falling out), and insert guide into power piston nut. Secure ball guide with clamp. Remove valve assembly from holding tool.

7) Install greased needle roller bearing in end cover. Install "O" ring and teflon ring in inner side of end cover. Run-in rings after installation. Fit "O" ring on outer side of end cover. Position thrust washer on cross shaft adjusting screw. **NOTE** — Position washer with side having chamfered inner diameter facing screw head. Assemble cross shaft on end cover. Install washer and nut finger-tight. **NOTE** — Ensure cross shaft turns the assembly.

8) Mount gear housing on holding tool and clamp on vise. Fit two "O" rings in gear housing (valve side end face). Install valve assembly with power piston nut. **CAUTION** — When placing valve housing into close contact with gear housing, do not turn housing as it may damage "O" rings. Hold power piston nut from turning during installation. Bolt valve housing to assembly, torquing to specification. **NOTE** — The second bolt at left of pressure hose inlet is a short bolt.

9) Turn worm shaft to center power piston nut rack with centerline of cross shaft installation hole. Insert cross shaft (with end cover attached) into gear housing. Mesh center of cross shaft teeth with center of power piston nut rack. Do not turn shaft. Bolt on end cover.

10) Set preload with cross shaft adjusting screw so that worm shaft starting torque in 4.9-7.7 lbs. as measured at worm shaft. Lock adjuster plug and adjusting screw by staking threads.

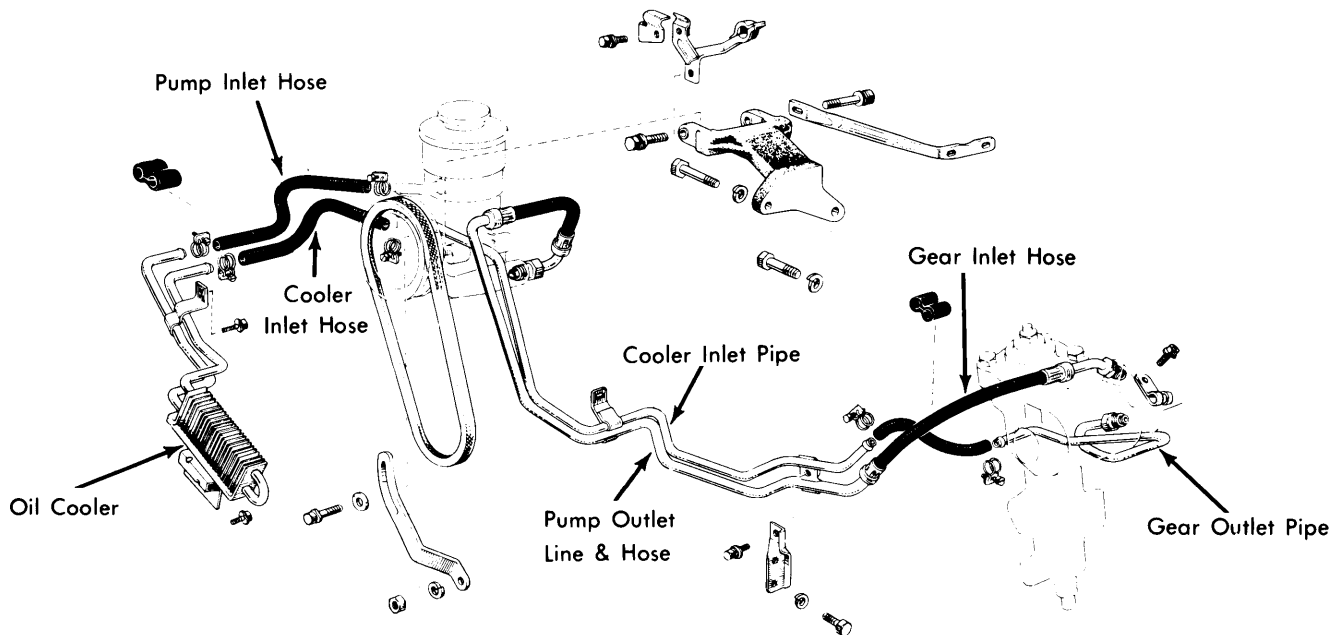

2T0020

POWER STEERING LINE & HOSE PLACEMENT

1971-73 TOYOTA CORONA MARK II & CROWN POWER STEERING (Cont.)

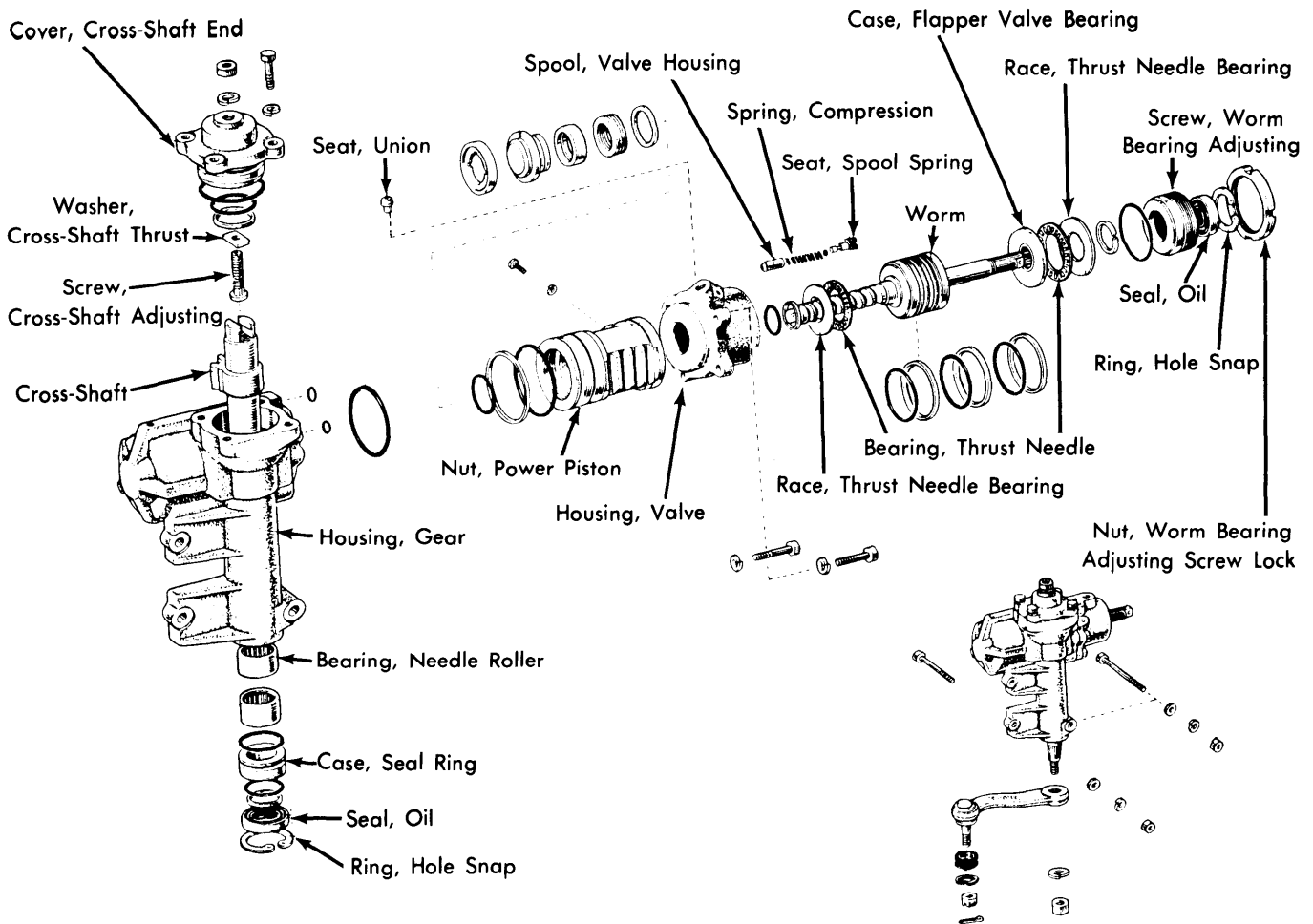

2T0022

POWER STEERING GEAR ASSEMBLY

TIGHTENING SPECIFICATIONS

Application	Ft. Lbs. (mkg)
Pump Housing & Bracket Bolts	22 (3.0)
Hose Union-to-Pump Housing	42 (5.8)
Rear Reservoir Bolts	4 (0.5)
Worm Bearing Adjusting Screw Lock Nut	83 (11.4)
Cross Shaft End Cover	35 (4.8)
Valve Housing-to-Gear Housing	35 (4.8)
Gear Housing-to-Frame	43 (5.9)
Cross Shaft-to-Pitman Arm	90 (12.4)
Pulley-to-Pump	32 (4.4)