

Power Steering

1971-72 ROVER 3500S POWER STEERING

3500S (1971-72)

DESCRIPTION

STEERING GEARS

Steering gears are an Adwest hourglass worm and roller follower type. Upper section of steering box incorporates a hydraulically driven piston and rack assembly. A belt driven hydraulic pump furnishes power to operate piston and rack assembly.

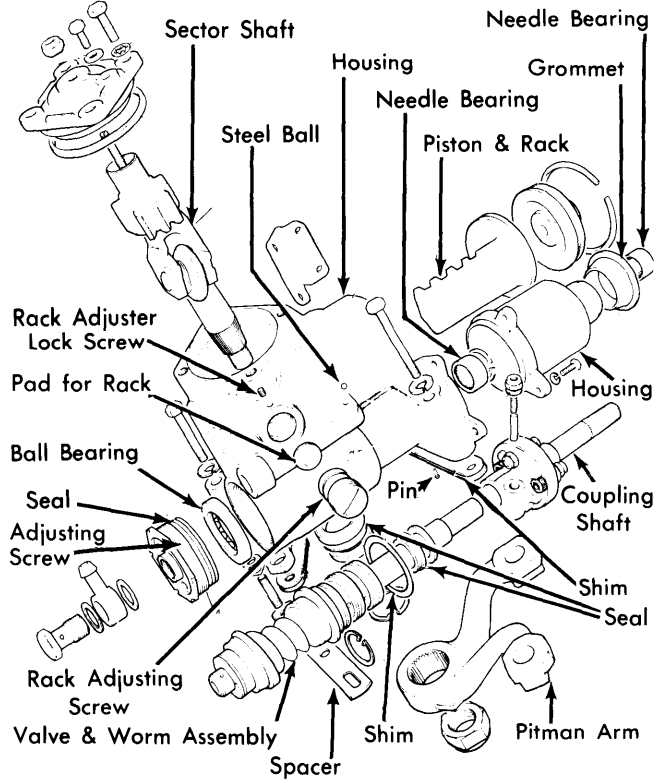

69R03

POWER STEERING GEARBOX

STEERING LINKAGE

Steering linkage is connected to pitman arm with a center link, which is attached to steering idler damper assembly. Tie rods with ball joints are connected to pitman arm and idler damper relay arm. Opposite end of tie rods are connected to steering arms.

POWER STEERING PUMP

Power steering pump is a belt driven roller/vane type pump. A separate fluid reservoir supplies hydraulic oil to pump. Pump supplies hydraulic pressure to steering box piston and rack assembly.

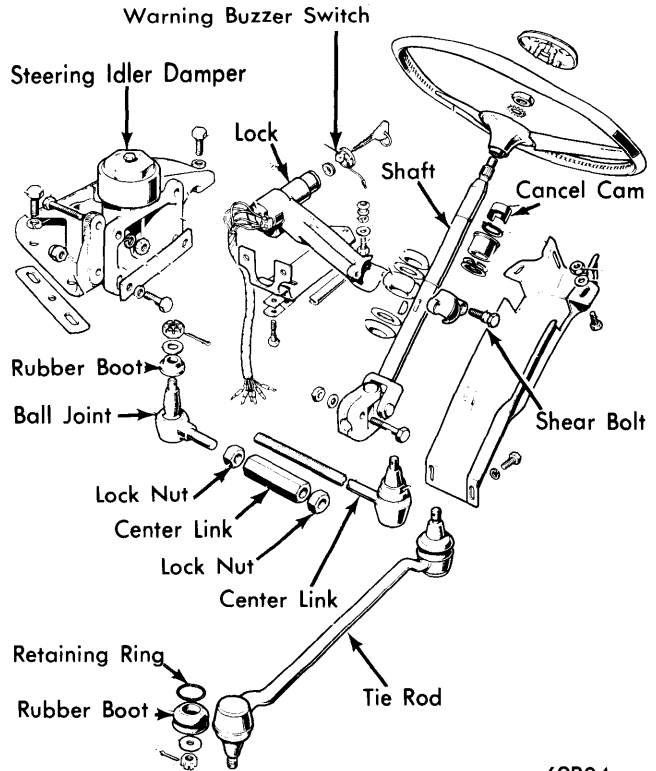

69R04

STEERING LINKAGE

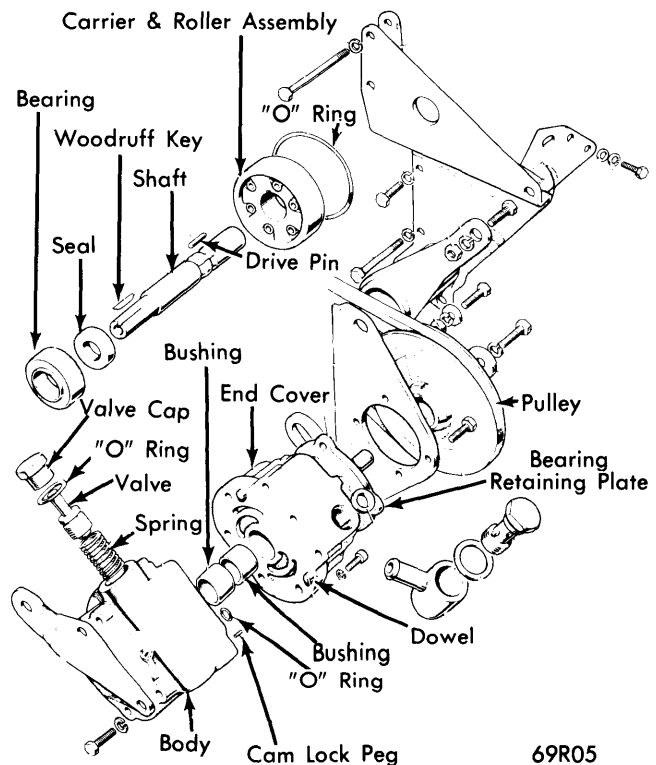

69R05

POWER STEERING PUMP

1971-72 ROVER 3500S POWER STEERING (Cont.)

LUBRICATION

Fluid Capacity – 4.8 qts.

NOTE – Never start engine until fluid reservoir is filled or damage to pump will result.

ADJUSTMENT

PUMP BELT

Loosen adjusting bolt and position pump so there is 7/16-9/16" free play midway between pulleys (see illustration).

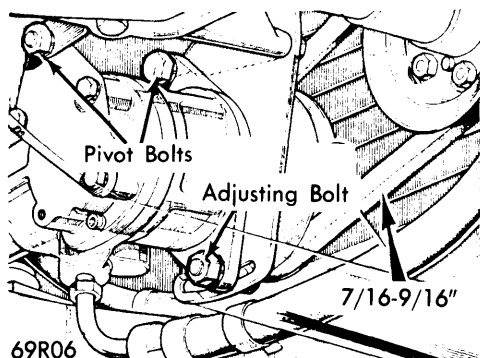

69R06
POWER STEERING BELT ADJUSTMENT

HYDRAULIC PUMP BLEEDING

1) Fill steering oil reservoir to "F" mark on dipstick with Mobil ATF210 or equivalent. Start engine and allow to warm up to normal idle speed. Leave engine at idle speed.

CAUTION – During following procedure, keep steering reservoir full, and **DO NOT** increase engine speed or move steering wheel.

2) Loosen bleed screw. When oil seepage past bleed screw is observed, retighten screw. Make sure fluid level is at "F" mark on dipstick. Check all hose joints under pressure for leaks by turning steering to stop. Do not hold steering to stop for more than 30 seconds in any one minute to avoid overheating hydraulic oil. Road test vehicle.

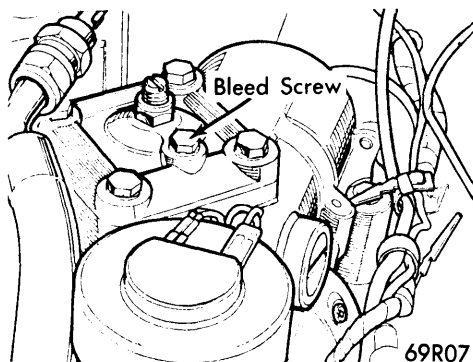

69R07
BLEEDING STEERING SYSTEM

STEERING GEAR BACKLASH

Jack up front of vehicle until wheels are clear of ground. Gently rock steering wheel around straight ahead position. Loosen lock nut and turn adjusting screw until a maximum of 3/8"

backlash is achieved at steering wheel rim. Tighten lock nut and check from lock-to-lock for excessive tight spots. Road test vehicle.

STEERING GEAR ALIGNMENT

Roll vehicle forward with wheels straight ahead. Measure toe-in, loosen lock nuts at each end of center link and turn link until $1/8 \pm 1/16$ " toe-in is achieved. Tighten lock nuts and roll vehicle ahead again and recheck toe-in measurement.

REMOVAL & INSTALLATION

POWER STEERING PUMP

Removal – 1) Drain cooling system and remove radiator. Remove reservoir filler cap and disconnect reservoir-to-pump hydraulic line, allowing fluid to drain into a container. Do not reuse this hydraulic fluid, replace with new fluid.

2) Remove pump-to-steering box high pressure line at pump. Remove pump attaching bolts and disconnect drive belt. Lift out pump.

Installation – 1) Position pump and install drive belt. Install pivot and adjusting bolts, tension drive belt. See *Pump Belt* in *ADJUSTMENT* Section.

2) Reconnect reservoir-to-pump and pump-to-steering box hydraulic lines. Refill system with hydraulic fluid and bleed system. See *Hydraulic Pump Bleeding* in *ADJUSTMENT* Section.

3) Install radiator and fill cooling system. Test steering, with engine running, by holding steering on full lock in both directions. **Do Not** maintain this pressure for more than 30 seconds in any one minute to avoid overheating fluid and causing damage to seals. Road test vehicle.

POWER STEERING GEARS

CAUTION – Engine must **NEVER** be started until reservoir has been filled or damage to pump will result.

Removal – 1) Remove air cleaner and cap from steering fluid reservoir. Disconnect hydraulic lines from pump and drain fluid. Disconnect lines from steering box. Jack up front of vehicle so wheels may be turned to steering stops.

2) Remove cotter pins and castle nuts from ball joints at pitman arm. Using suitable extractor (565446), pull ball joints. Remove hardware attaching accelerator bracket to steering box. A010

3) Remove bolts, lock plate, special nut and lock washers attaching steering box to base unit. Remove pinch bolt, nut and washers from steering column universal joint, accessible from behind glove compartment.

4) Remove steering box complete, vary pitman arm position to ease removal.

NOTE – There may be spacing plates fitted between steering box and base unit, these must be retained for reassembly.

Installation – 1) Replace spacer plates if fitted, between steering box and base unit. Install steering box, feeding shaft into steering column universal joint.

2) Install bolts, special nut and lock washers. Special nut must be installed first to located steering box (see illustration). To install remaining components, reverse removal procedures. Fill steering reservoir, check wheel alignment and test system for leaks.

1971-72 ROVER 3500S POWER STEERING (Cont.)

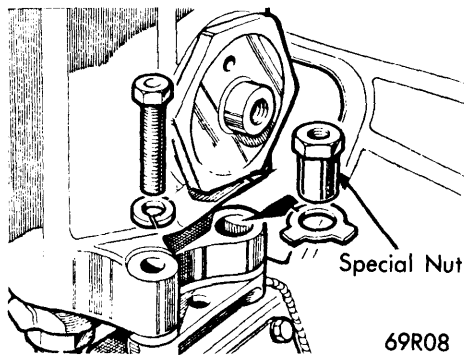

STEERING BOX INSTALLATION

STEERING LINKAGES

Center Link Removal – 1) Remove air cleaner. Jack up front of vehicle so wheels can be turned to steering stops. Remove cotter pins and castle nuts from center link ball joints.

2) Using suitable extractor (565446 or 606606), remove ball joints from pitman arm and steering idler arm. Withdraw center link from under either left or right inner fender panel.

NOTE – It is necessary to disconnect and lower torsion bar to enable steering idler arm ball joint to be removed.

Installation – Install new rubber boots if necessary. Use new cotter pins on all ball joints. To install, reverse removal procedures. Lower vehicle and reset wheel alignment.

Tie Rod Removal – Raise front of vehicle and place axle on floor stands. Remove wheel. Remove cotter pins, castle nut and washer from ball joints. Using suitable extractor (565446), remove ball joints from pitman arm and steering knuckle. Withdraw tie rod from vehicle.

Installation – Install new cotter pins and, if necessary, new rubber boots. To install, reverse removal procedures. Replace wheel, lower vehicle and check wheel alignment.

Steering Idler Arm Assembly Removal – 1) Jack up front of vehicle so wheels may be turned to steering stops. Remove cotter pins, castle nuts and washers from tie rod and center link ball joints. Remove ball joints using suitable extractor (565446).

NOTE – Armstrong steering damper must not be disassembled. If there are any signs of leaking replace unit. Steering damper arm must not be removed as location of arm-to-internal vanes is highly critical.

2) Disconnect steering hose clamp from bracket on steering idler. Remove attaching bolts from fluid reservoir and move reservoir to one side.

3) Remove bolts and lock washers attaching mounting bracket to base unit, and remove idler damper assembly complete. Remove mounting and angle brackets from damper assembly.

NOTE – Spacing plates may be fitted between damper mounting plate and base unit. Spacer plates must be reinstalled during installation.

Installation – To install, reverse removal procedures using new cotter pins. Check wheel alignment.

OVERHAUL

POWER STEERING PUMP

Disassembly – 1) Remove bolt, washer, and pulley from pump. Remove front mounting bracket, body end-plate and rear bracket.

2) Clamp pump body in a vise. Remove adaptor screw, adaptor fiber washer and rubber seal. Venturi flow director is pressed into cover and should not be removed.

3) Remove Allen screws attaching cover to pump body, and remove pump from vise. Separate cover from body vertically to prevent parts from falling out. Remove "O" rings from groove in pump body.

4) Remove the six rollers from carrier vanes. Slide carrier off shaft and remove drive pin. Remove shaft, cam and cam lock peg from pump body. If necessary remove Woodruff key from shaft and withdraw ball bearing.

5) Remove shaft seal from body, using care not to damage shaft bushing. Remove valve cap, valve and valve spring from body. Wash all parts in suitable solvent, air dry or wipe clean with a lint free cloth. Check pump body and cover for wear. Replace either part if faces or bushings are worn.

Reassembly – 1) Install a new shaft seal in pump body with lip toward carrier pocket. Install cam lock peg in hole in pocket. Install cam in pocket with slot over retaining pin, make sure cam is seated on pocket face.

2) Insert shaft from seal side of body. Replace carrier drive pin in shaft. Inspect carrier and place in position so that greater angle on vane is in leading position (see illustration).

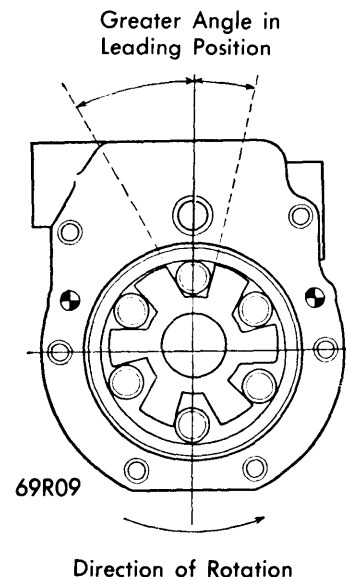

INSTALLATION VANE CARRIER

3) Inspect rollers, replace if any signs of wear or scoring is present, especially on ends of rollers. Insert rollers between carrier vanes. Measure clearance using a straightedge across cam face and a feeler gauge, if clearance exceeds .002" replace carrier and rollers (see illustration).

1971-72 ROVER 3500S POWER STEERING (Cont.)

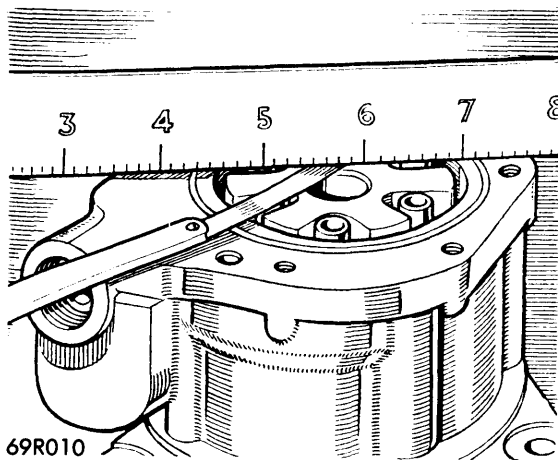

CARRIER & ROLLER CLEARANCE MEASUREMENT

4) Replace flow control valve spring in bore. Spring tension should be 8-9 lbs. @ .820". If not, replace with new spring. Insert valve so that exposed ball end enters last. Check that valve is not sticking.

5) Install "O" ring on valve cap. Screw cap in pump and torque to 30-35 ft. lbs. Install new "O" rings in grooves of pump body. Replace cover on pump body and tighten Allen screws.

6) Install square sectioned oil seal to groove around inlet port. Install adaptor, fiber washer and adaptor screw. Position end plate to body with larger radius in line with valve. Install front and rear bracket to pump body. Replace drive pulley and torque bolt to 10-12 ft. lbs.

POWER STEERING GEARS

Disassembly - 1) Using a suitable extractor, remove pitman arm from sector shaft. Set input shaft to straight ahead position, approximately 1 1/2 turns from either full lock position. Unscrew attaching screws and slide bell housing off input shaft.

2) Loosen nut from cotter pin, until nut is level with end of thread. Drive cotter pin out of hole. Complete removal of nut and washer. Slide rubber coupling assembly off rotor.

3) Loosen top cover so sector shaft can be disengaged from worm and rack. Remove cylinder cover circlip. Remove cylinder cover complete with seal.

4) Screw a long 1/2" bolt into hole in center of piston and rack. Withdraw assembly through open end of cylinder, also withdrawing sector shaft and cover to a position where piston rack will pass through gap between sector shaft teeth and rack.

5) Lift out rack adjuster thrust pad. Remove sector shaft and top cover from gear housing. Remove lock nut using suitable "C" wrench (606600). Remove worm adjusting screw using a suitable peg wrench (606601).

6) Remove valve and worm assembly by tapping input shaft with a hide mallet until assembly can be withdrawn, together with outer ball bearing and bearing race. Retain any shims used between outer race and steering box casting.

7) Loosen lock screw and remove rack adjustment screw. Remove top cover from sector shaft assembly. No further disassembly is required.

NOTE - Do not disturb the relationship between worm and valve sleeve by moving trim screw.

Replacement - 1) On external seals, remove circlip retaining sector shaft seal. Using a hook, pull out seal washer and seal. Remove circlip, washer and seal for rotor shaft, using care that valve housing and bearing shims are not lost.

2) On internal seals, cut worn or damaged teflon seals from valve sleeve. Using suitable seal expander (606602), slide new teflon seal into place. After seal is located in groove, use suitable seal compressor (606603) to size teflon seal so that it fits snugly in valve groove and has slight interference with bore of valve housing (see illustration).

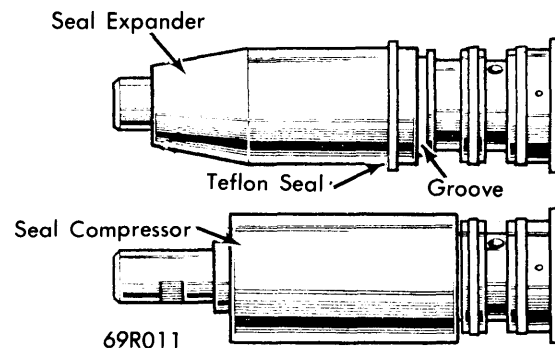

FITTING TEFLON SEAL

3) Cut teflon piston ring off of piston and pry out "O" ring under seal. Install new "O" ring and pry teflon piston ring on as you would a tire on a rim. Use care not to over stretch teflon seal.

4) Examine needle bearing and rubber bushing in bell housing for wear or damage. If new rubber bushing is installed, coat O.D. with suitable adhesive and press fully into housing.

5) Check rubber element in coupling assembly for wear or damage. Install rubber element and tighten bolts until they start to compress rubber, then tighten lock nuts.

6) On sector shaft, check roller for preload on thrust bearings. It should be free to rotate, but slightly stiff with no side play. Check adjusting bolt in top of sector shaft. It should have .000-.005" end play. Inspect sector teeth and bearing areas for wear, replace if necessary. Examine remaining components for wear, damage or excess clearances.

NOTE - Check that there is no excessive end play at trim pin between valve sleeve and worm.

Reassembly - 1) During reassembly, torque resistance checks are carried out to determine preload imposed on shaft rotation by seals and bearings with shafts and gears in a "no load" condition, that is with adjuster screws in position but not loading components. Torque figures obtained at each "no load" check are to be noted; these figures will be increased by a specified amount when final adjustments are made to steering box. All torque checks are made at input shaft in straight ahead position (input shaft 1 1/2 turns from either full lock position).

2) Position original shims and inner bearing outer race in valve and worm housing bore, install ball bearing. With suitable seal saver (606605), lower valve and worm assembly into position (see illustration). Install outer ball bearing.

Power Steering

1971-72 ROVER 3500S POWER STEERING (Cont.)

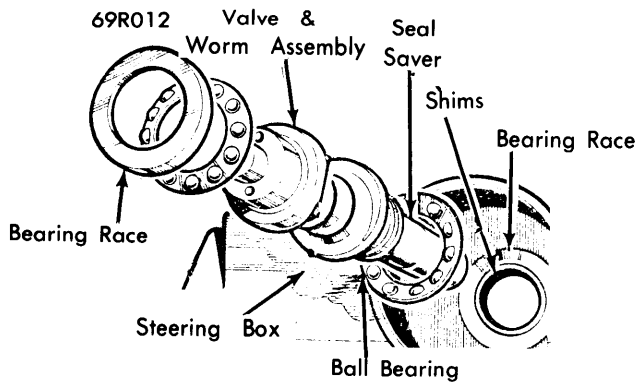

VALVE & WORM ASSEMBLY INSTALLATION

3) Screw adaptor screw in until end play is eliminated, but with valve assembly free to turn. Loosely tighten lock nut. Check torque resistance at input shaft and note torque figure. Turn adaptor screw until torque is increased by 2 INCH lbs.

4) Hold adapter screw stationary, using suitable peg wrench (606601) and "C" wrench (606600), tighten lock nut (see illustration). Recheck torque figure with lock nut tight.

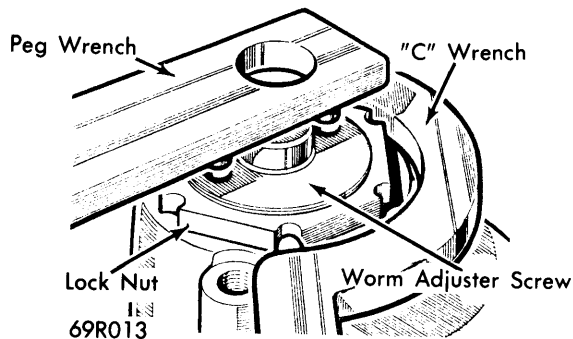

VALVE & WORM ADJUSTER SCREW

5) With suitable seal saver (606604) installed on splined end of sector shaft. Slide shaft into gear housing with roller positioned toward middle of cam. Install sector shaft complete with seal saver and cover into housing until gap between sector shaft teeth and roller is in line with middle of piston bore in main housing (see illustration).

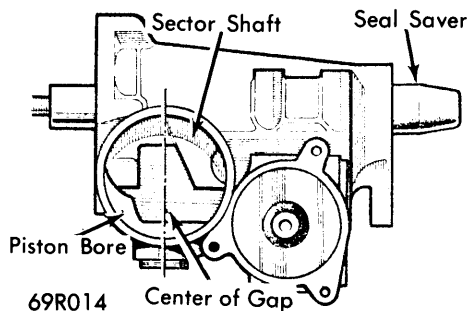

SECTOR SHAFT INSTALLATION

6) Screw a long 1/2" bolt into center of piston assembly. Place piston and rack into cylinder so rack passes between teeth on sector shaft and roller with center gap on rack meshed with center tooth on sector shaft (see illustration).

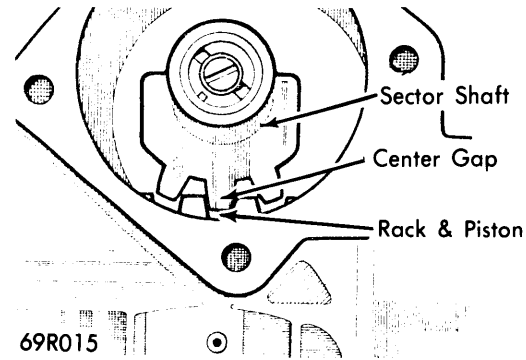

RACK & PISTON INSTALLATION

7) Move back of rack as far away from sector shaft as possible and push home sector shaft, aligning Worm with roller by turning input shaft. Move rack away from adjusting screw hole, check that mesh is correct.

8) Remove Nylock nut from top of adjuster screw. Screw cover assembly onto adjuster screw as far as it will go. Bleed screw should be positioned such that it will be inboard when unit is remounted in vehicle.

9) Install four screws and lock washers attaching cover, torque to 42 ft. lbs. Check that there is play between roller and worm, if not, back off adjusting screw until there is play.

10) Position rack pad in its seat in rack adjusting screw. Install new rack adjuster seal and insert assembly in gear housing with pad in correct position. Loosely tighten rack screw and lock nut.

11) Install cylinder cover, seal and circlip. With input shaft 1 1/2 turns from either lock, adjust sector shaft adjusting screw until there is almost no backlash in sector shaft. Hold adjusting screw and tighten lock nut.

Adjustment - 1) Check torque resistance to rotation at input shaft as follows: With input shaft end toward operator, turn shaft fully counterclockwise. Turn shaft fully clockwise and note where maximum torque peaking is obtained. Torque peak should occur at straight ahead position. If torque peak occurs before center position add shims. If peak occurs after, subtract shims from between valve and worm assembly inner bearing outer race and steering box casting.

2) To adjust sector shaft, place gear in center position and check torque figure required to rotate input shaft. Loosen lock nut and tighten adjuster screw until input shaft torque increases by 4 INCH lbs. as shaft passes through center position. Tighten lock nut.

1971-72 ROVER 3500S POWER STEERING (Cont.)

3) To adjust rack-to-sector clearance, screw in rack adjuster screw until all free travel is taken up and check that gear is free from lock to lock by turning input shaft. Tighten rack screw until there is a maximum increase of 16 INCH lbs. Tighten locking set screw.

4) Measure distance between mounting feet on main housing and small end of longer pitman arm. Measurement should be .885-.945" (see illustration). Shim to the required measurement. This dimension will not require adjustment unless a new sector shaft has been installed.

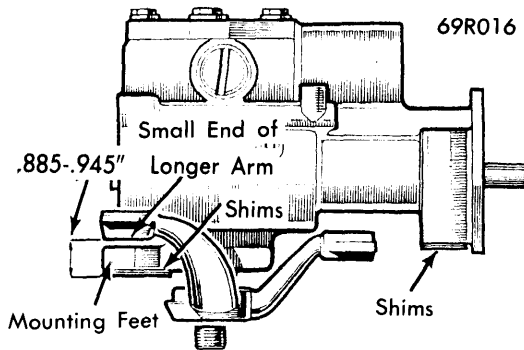

MOUNTING FEET-TO-PITMAN ARM MEASUREMENT