

## 1969-73 BMW POWER STEERING

6 Cylinder (1969-73)

### DESCRIPTION

#### STEERING GEAR

Power steering gear consists of a gear housing containing a sector shaft with sector gear, a power piston with gear teeth in side of piston which is in constant mesh with sector shaft teeth, and a worm shaft connecting steering shaft to power piston through a universal joint coupling. Worm shaft is geared to piston through recirculating ball contact; and a steering valve is incorporated into upper end of worm gear assembly.

#### STEERING PUMP

Power steering pump is a high pressure, belt driven, vane type pump. A fluid reservoir incorporating a filter element supplies hydraulic fluid to pump. Pump maintains hydraulic pressure to power steering gear assembly.

### LUBRICATION

#### CAPACITY

System Capacity - 2.54 pints (1200 cc).

#### LUBRICANT TYPE

**Initial or Subsequent Filling** - BMW recommends Veedol Automatic Transmission Fluid ATF Special 3433.

**Subsequent Filling (Max. 1/2 pint - 1/4 liter)** - Veedol Automatic Transmission Fluid Type A Suffix A AQ 1407 A, or suitable equivalent.

### ADJUSTMENT

#### PUMP BELT

Loosen adjustment bolts and shift pump to tighten belt. Adjustment is correct when it is possible to press in belt 0.2-0.4" (5-10 mm) with the thumb.

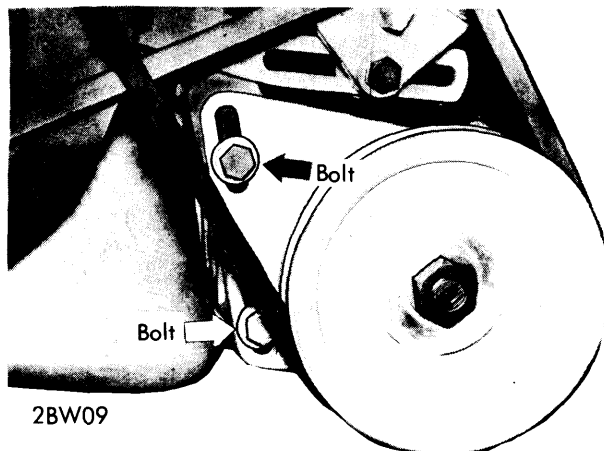

2BW09

BELT ADJUSTMENT

#### HYDRAULIC SYSTEM BLEEDING

1) Power steering must be bled whenever system is opened, or oil level falls so low that the vane type pump picks up air. Fill reservoir to upper mark with fluid. Turn engine over with starter and continue to add fluid. When oil level no longer falls, start and run engine at idle speed.

2) Turn steering wheel rapidly from lock to lock and back until no further air bubbles rise in reservoir. During this operation, and when completed, fluid level must remain at upper mark.

#### SECTOR SHAFT

**Adjustment (In Vehicle)** - 1) Disconnect steering linkage from pitman arm. Remove center cover from steering wheel. Count number of turns required to turn steering wheel from lock to lock, then turn wheel back half way to center steering gear. Turn steering wheel about one turn to left. With a suitable torque wrench attached to steering wheel nut, turn wheel to right through the straight-ahead position and observe torque reading at this point. Torque required should be 8.7-10.4 INCH lbs. (10-12 cmkg).

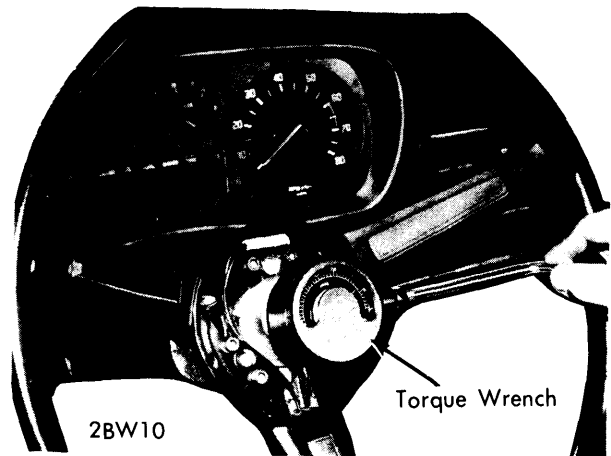

CHECKING SECTOR SHAFT ADJUSTMENT

2) Before adjusting, turn steering wheel about one turn to left of straight-ahead position. Loosen lock nut and turn adjusting screw until correct torque is obtained when steering wheel passes through the straight-ahead position. Tighten lock nut and recheck adjustment.

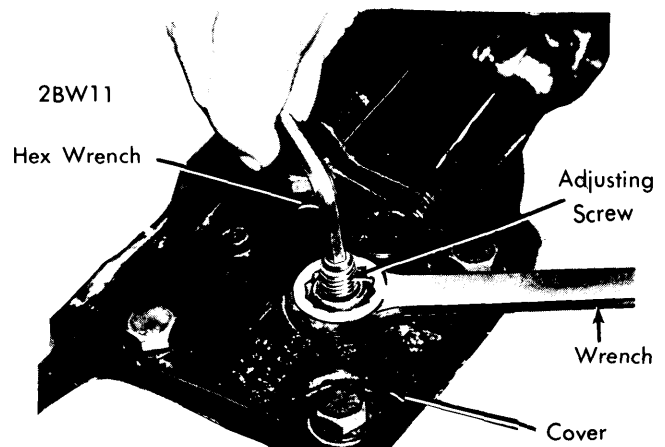

2BW11

ADJUSTING SECTOR SHAFT

## 1969-73 BMW POWER STEERING (Cont.)

## REMOVAL &amp; INSTALLATION

## STEERING GEAR

**Removal** – 1) Turn steering to full left lock. This will move piston to top of its travel. Remove plug in gear housing and drain fluid. **CAUTION** – Do not re-use fluid drained from steering. Disconnect steering linkage from pitman arm.



DRAINING GEAR HOUSING

2) Mark universal joint and steering worm shaft for reassembly reference. Remove lower bolt from universal joint. Loosen upper bolt and drive universal joint upwards as far as possible on steering shaft. Disconnect hoses from steering gear. **CAUTION** – Seal hose connections with dust caps. Separate steering gear from front axle beam and remove downwards.

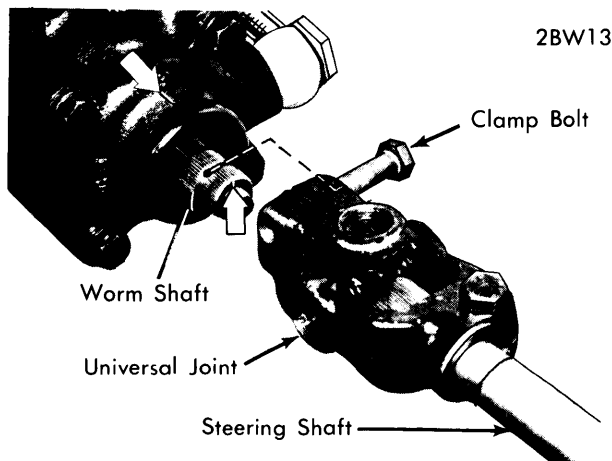

UNIVERSAL JOINT COUPLING

**Installation** – To install, reverse removal procedure and note the following: For hydraulic system bleeding, see Adjustment above.

## STEERING PUMP

**Removal** – Disconnect hoses from steering pump. **CAUTION** – Do not re-use fluid drained from pump and hoses. Loosen pump mounting bolts and remove drive belt, then remove bolts and lift out pump.

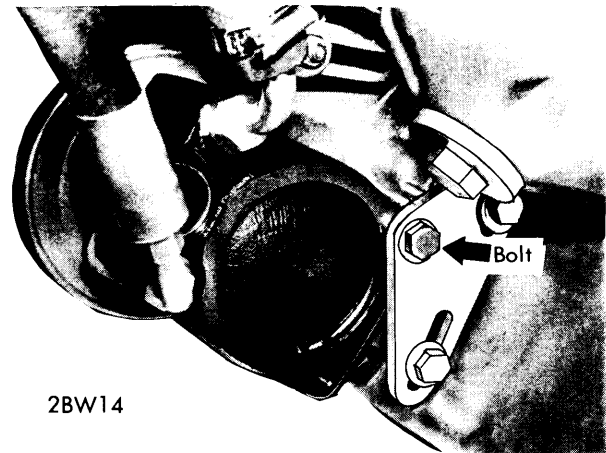

POWER STEERING PUMP

**Installation** – To install, reverse removal procedure and note the following: For pump belt adjustment and hydraulic system bleeding, see Adjustment above.

## STEERING GEAR OVERHAUL

## DISASSEMBLY

**Pitman Arm** – 1) Mark pitman arm and sector shaft for reassembly reference then, using a suitable puller, remove pitman arm.

2) When installing: Align marks on pitman arm and sector shaft. Install lock washer with longer of two metal tabs on right of pitman arm (looking forward).

**Sector Shaft Cover** – 1) Remove adjusting screw lock nut and bolts from cover. Remove cover by turning adjusting screw clockwise through cover.

2) When installing: Inspect "O" ring in cover and replace if necessary. Before tightening cover bolts, turn adjusting screw until cover is firmly seated.

**Sector Shaft** – 1) Center sector shaft gear in housing and remove shaft.

2) Check end play of adjusting screw. Head of screw is held in sector shaft by a washer and snap ring. End play between adjusting screw and sector shaft is controlled by thickness of washer. End play should be .002" (.05 mm). Replace washer if necessary with one of correct thickness to obtain desired end play.

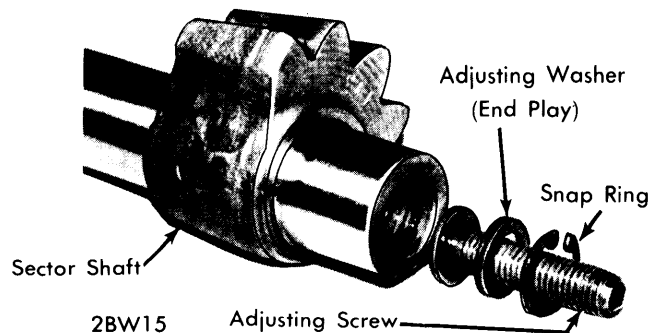

SECTOR SHAFT ADJUSTMENT SCREW

## 1969-73 BMW POWER STEERING (Cont.)

3) When installing: Pack splines of shaft with high temperature grease and insert shaft carefully to avoid damaging seals.

**Sector Shaft Bearings** - 1) From pitman arm end of housing, remove snap ring and oil seal. Remove needle roller bearing with a suitable puller. Drive upper needle roller bearing, thrust washer, and oil seal out of housing.

2) When installing: Oil seal lips must face interior of steering gear housing.

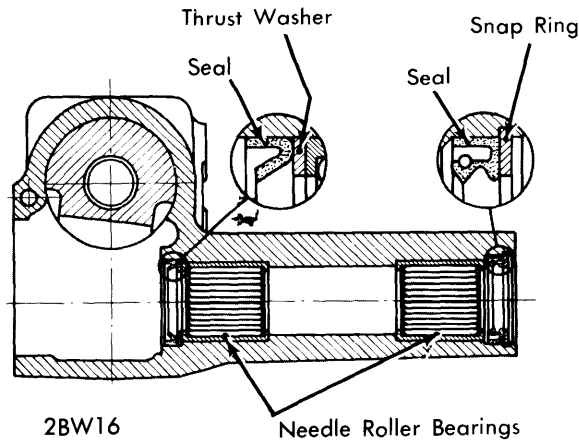

**SECTOR SHAFT BEARINGS**

**Valve Housing** - 1) Remove protective cap from end of valve housing, then remove housing. Remove the ball bearing.

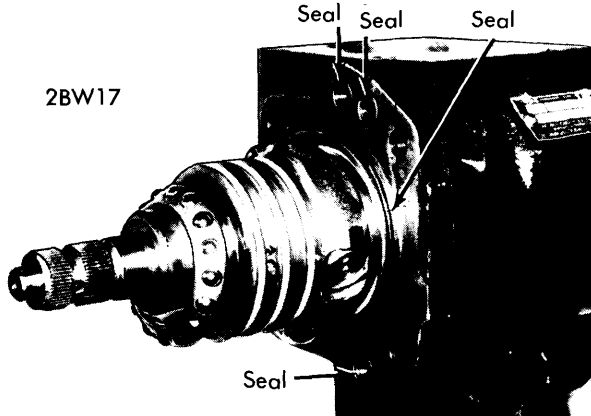

**VALVE HOUSING SEAL LOCATIONS**

2) If needle roller bearing is to be replaced: Press off bearing race, then remove the double needle roller cage. Remove bearing race from valve housing with a suitable puller.

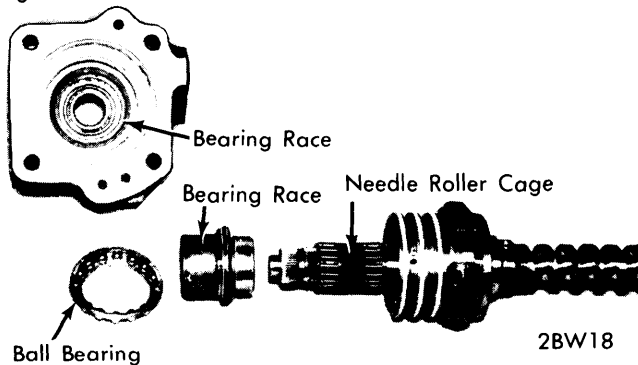

**SHAFT BEARING LOCATIONS**

3) When installing: Install bearing and needle roller cage without play. To accomplish this, the needle roller cages are available in four different sizes. **CAUTION** - Adjust torque value with bearing disc, as outlined under Intermediate Cover below. Inspect sealing rings (four used) and replace if necessary. Cover worm shaft splines with Scotch tape to prevent damage to seal when installing housing.

**Intermediate Cover** - 1) Remove worm with intermediate cover and piston from gear housing. Unscrew worm from piston. **CAUTION** - Do not lose balls. Remove intermediate cover, then remove recirculating tube. Inspect needle roller cage, bearing washer, slotted ring, "O" ring, and sealing ring. **NOTE** - The shim washer is required for adjusting position of slotted ring. Inspect cover sealing rings (four used).

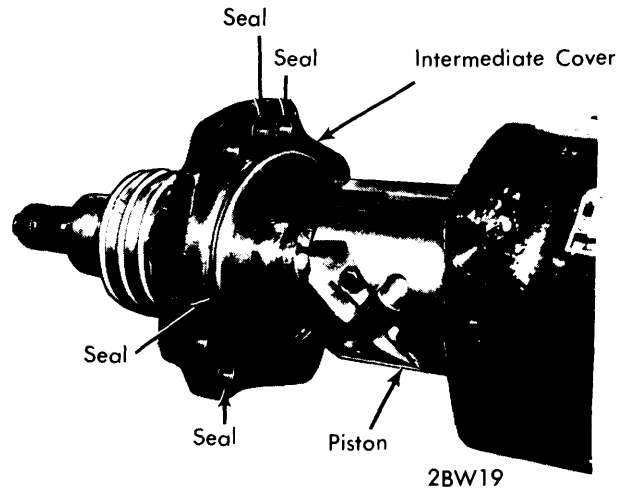

**INTERMEDIATE COVER SEAL LOCATIONS**

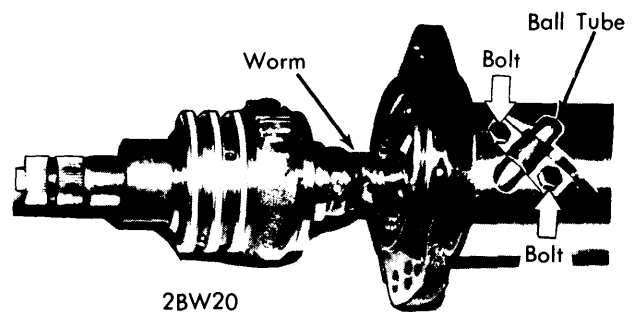

**REMOVING WORM FROM PISTON**

2) Temporarily assemble valve housing without ring seal, worm head without Teflon sealing rings, intermediate cover without "O" ring and slotted ring with ball bearing, needle roller cage and bearing washer to valve housing, and tighten screws evenly. Install torque wrench and check preload of worm bearing. Replace bearing washer if necessary with one of correct thickness to obtain torque specification shown in table at end of this article.

3) Check prestressing of Teflon ring in intermediate cap as follows: Place bearing disc and retainer ring in intermediate cap. Install "O" ring and Teflon ring (.067" (1.7 mm) thick) into groove, and install on worm shaft. Install a torque wrench and check preload with shaft in vertical position. Replace Teflon ring if necessary with one of correct thickness to obtain torque specification shown in table at end of this article.

# Power Steering

## 1969-73 BMW POWER STEERING (Cont.)

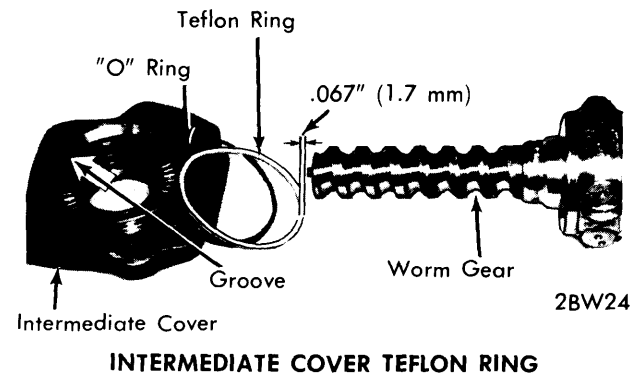
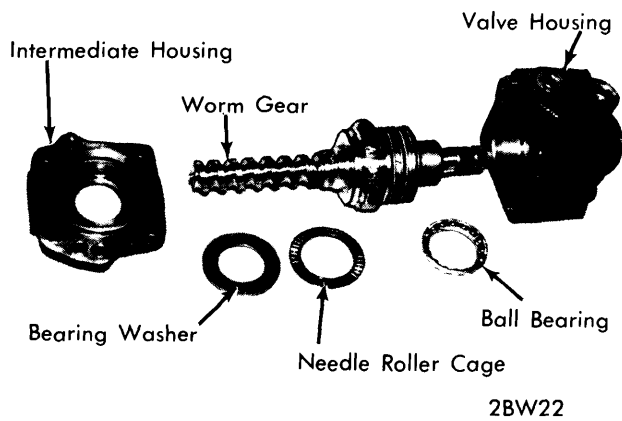
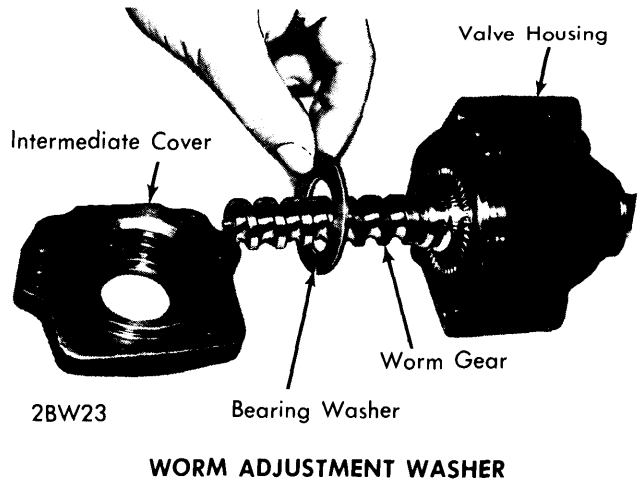
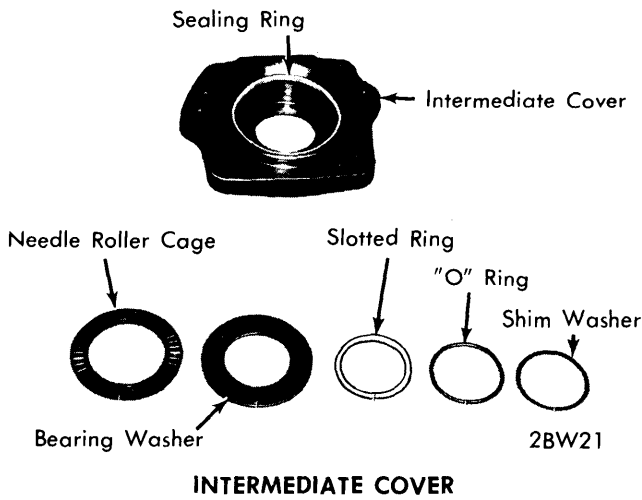

**Checking and Adjusting Overall Torque Value of Worm Gear** - 1) Before proceeding with check, verify the following: Teflon rings are installed in worm gear, and radial sealing ring installed in valve casing. Teflon ring is installed in intermediate cap, and frictional value of Teflon ring has been determined.

**Teflon Rings (Worm Gear & Piston)** - Replace Teflon rings (four rings) on worm gear and piston. Replace "O" ring (one ring) on worm gear. Use a suitable blade-type tool to push old rings out of grooves.

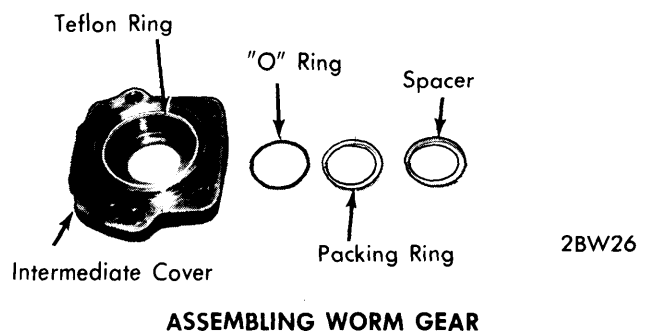
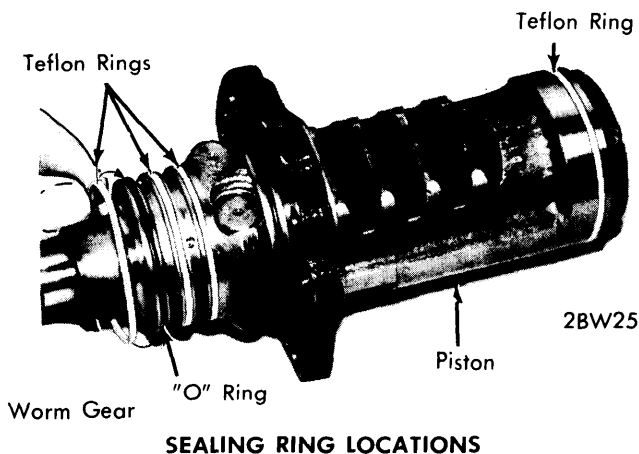
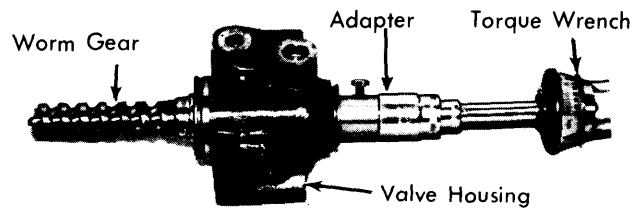

2) Install "O" ring and groove packing ring, with sealing tab facing towards piston, together with spacers removed earlier. Assemble worm gear into piston casing. Install and tighten in-

## 1969-73 BMW POWER STEERING (Cont.)

intermediate cover on valve casing. Install a torque wrench; determine overall torque value and compare with torque specification shown in table at end of this article.

3) By means of spacers, set prestress of groove packing ring 0.86 INCH lbs. (1.0 cmkg) higher than the torque value in the intermediate cover as determined earlier.

**Pistons and Worm** — 1) **CAUTION** — Do not remove the valve pistons. Check standard dimension of wheel locking valve. Distance from tip of worm to face of valve should be 4.207-4.215" (106.8-107.0 mm). If adjustment of valve to hydraulic center position is incorrect, or dimension of wheel locking valve is not within specification, replace unit.

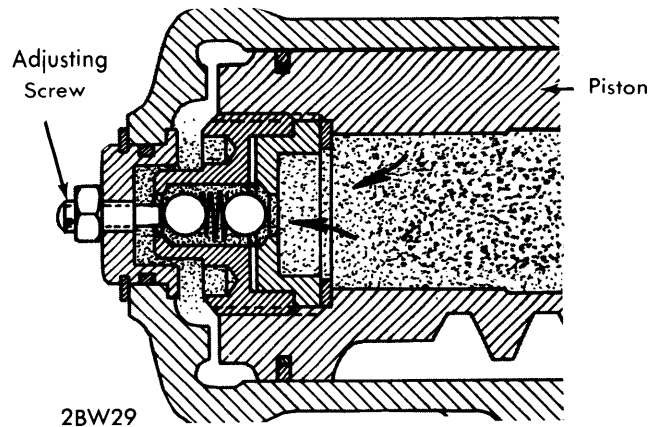

2BW29  
**WHEEL LOCKING VALVE ADJUSTMENT SCREW**

3) Install worm 1.576" (40 mm) into piston. Install 16 balls through front hole while turning worm. Place seven balls in circulation tube (retain end balls with grease). Install circulation tube on piston and lock bolts by bending over ends of clamp.

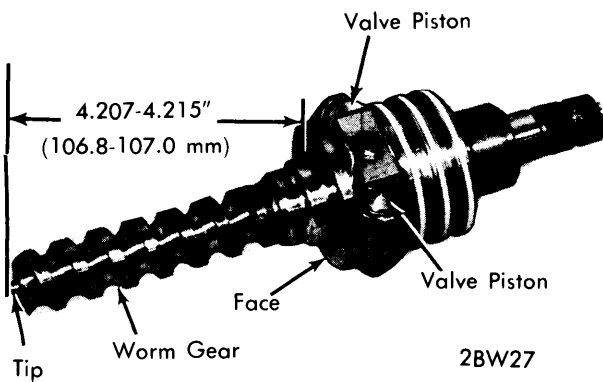

2BW27  
**MEASURING WORM FOR WHEEL LOCKING VALVE DIMENSION**

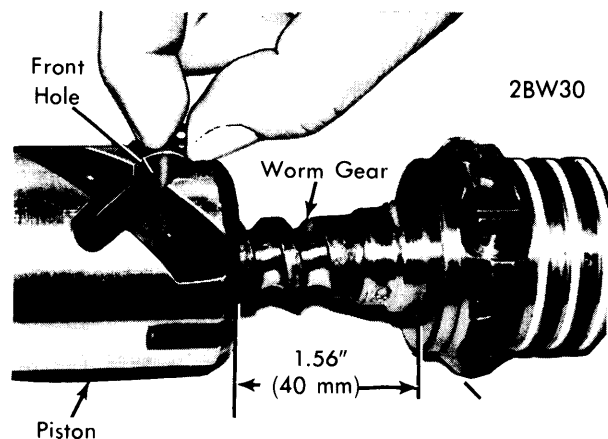

2BW30  
**INSTALLING BALLS IN PISTON**

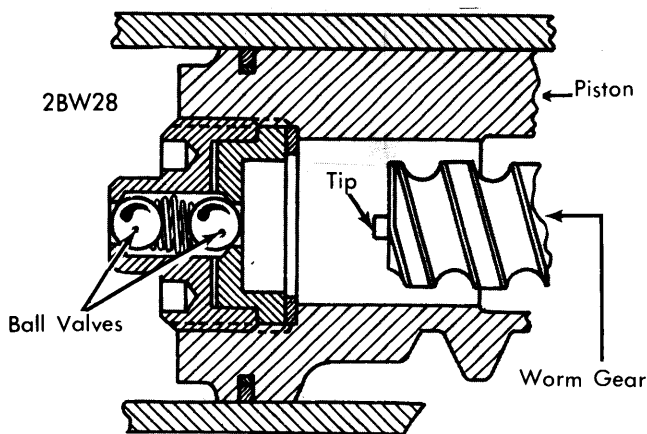

2BW28  
**WHEEL LOCKING VALVE**

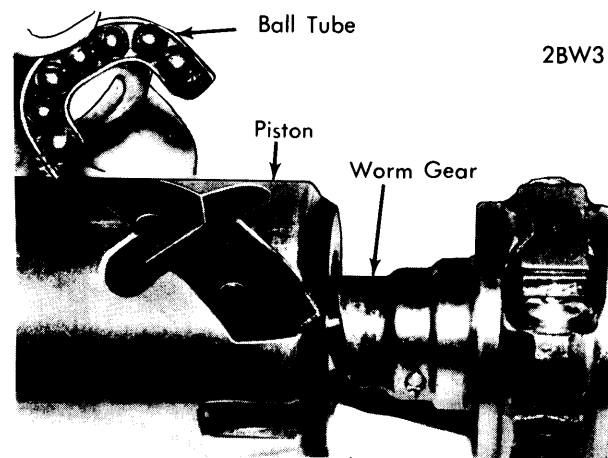

2BW31  
**BALLS RETAINED IN TUBE**

2) **NOTE** — Early models may have but one ball in wheel locking valve. Later models have a double ball valve for quieter operation. Wheel locking valve must open shortly before maximum wheel lock occurs. Turn adjusting screw until wheel locking valve opens .008" (2 mm) before steering arm reaches its stop.

4) Turn out worm approximately 3 1/2 turns. **CAUTION** — Never turn out worm more than 3 1/2 turns, as balls may fall into piston bore. Install a torque wrench and, with worm in horizontal position, measure torque value over a range of at

# Power Steering

## 1969-73 BMW POWER STEERING (Cont.)

least 90° and compare with torque specification shown in table at end of this article. Torque value is dependent on diameter of the balls. **CAUTION** — Use only balls with same diameter (tolerance groups). Remove worm after having adjusted torque value. Remove intermediate cover and connect worm to piston.

### REASSEMBLY

To reassemble, reverse disassembly procedure and note the following: To adjust sector shaft, determine center of worm shaft movement by halving the total number of turns. Turn back worm shaft one complete turn to left. With a suitable torque wrench attached to worm shaft, turn shaft clockwise through the center point and observe torque reading. Torque required should be 8.7-10.4 INCH lbs. (10-12 cmkg). Loosen lock nut and turn adjusting screw until correct torque is obtained as center point is passed. Tighten lock nut and recheck adjustment.

### STEERING PUMP OVERHAUL

#### DISASSEMBLY

1) Force down cover in a press and remove retainer ring. Remove cover, coil spring, and "O" ring. Remove end plate and "O" ring, noting location of pin in one of the small holes on end plate.

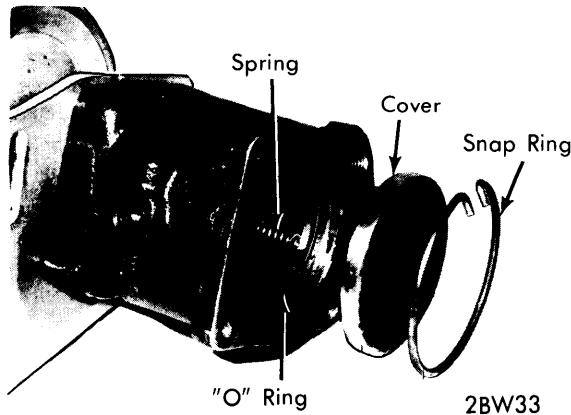

#### REMOVING END COVER

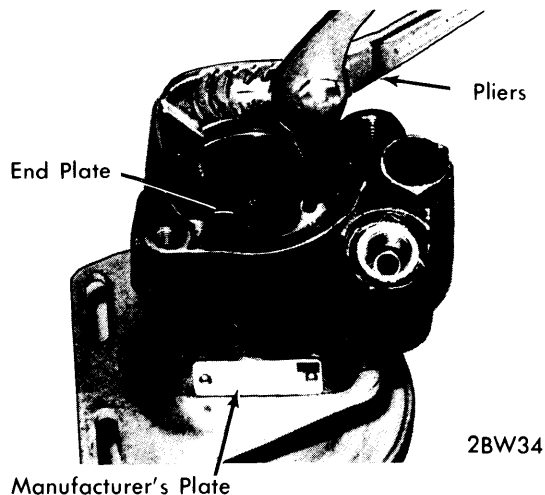

#### REMOVING END PLATE

2) Tilt housing and remove cam ring and rotor. Note that side of rotor with recessed hole faces drive shaft, the rounded off side of rotor faces cam ring, and the cast-in half arrow indicates direction of rotor rotation.

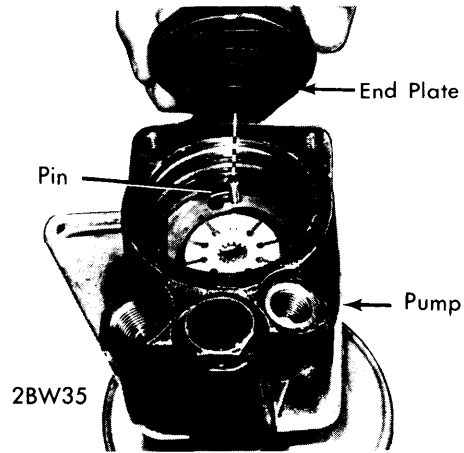

#### PIN LOCATION

3) Remove lower end plate and "O" ring. If it should be necessary to remove drive shaft, proceed as follows: Remove pulley, remove retainer ring from housing, then force out drive shaft. Inspect seal and needle roller bearing and replace if necessary. **NOTE** — Installed depth of needle roller bearing is 1.457" +.008" (37 +0.2 mm). Replace ball bearing on drive shaft if necessary.

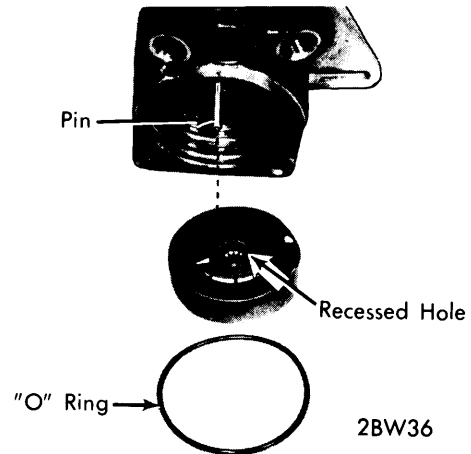

#### RECESSED SIDE OF ROTOR

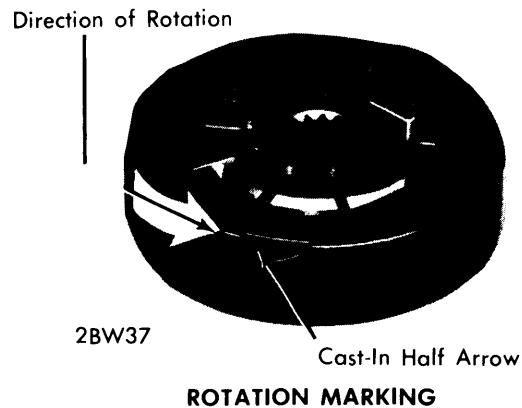

#### ROTATION MARKING

## 1969-73 BMW POWER STEERING (Cont.)

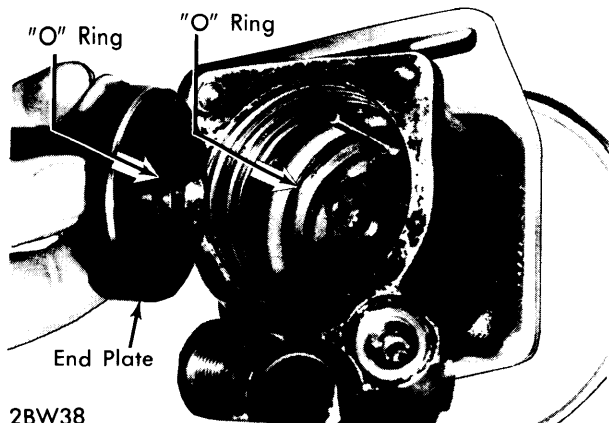

2BW38  
"O" RING LOCATIONS

4) Remove plug from pressure valve bore, then remove coil spring and valve piston. Note that threaded section on valve piston faces coil spring. **CAUTION** — Do not alter length of coil spring or thickness of plug sealing ring.

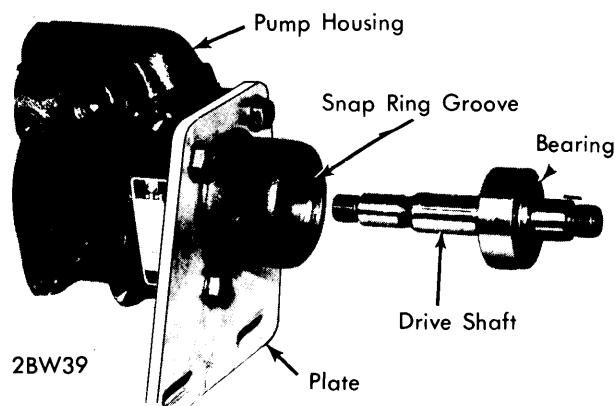

2BW39  
PUMP DRIVE SHAFT

5) The valve tolerance group (1 or 2) is stamped into housing adjacent to pressure valve bore and valve barrel should be scribed with one or two marks (lines) agreeing with group number stamped into housing. **CAUTION** — If valve must be replaced, install valve of same tolerance group.

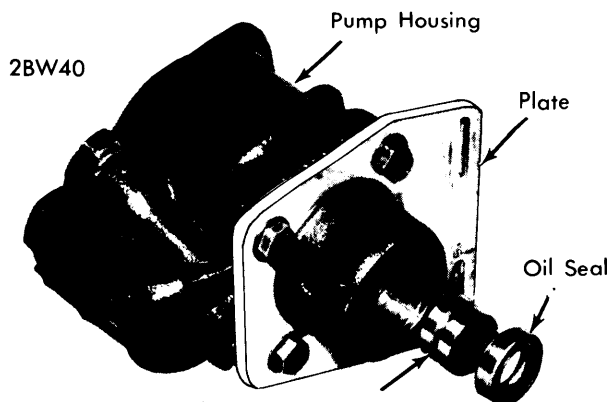

2BW40  
OIL SEAL & NEEDLE ROLLER BEARING

6) Clean and inspect all parts. Clean restrictor insert in pump outlet passage. Valve piston may be disassembled for cleaning. **CAUTION** — When disassembling piston, do not clamp across the sliding surfaces. A pressure valve is located inside valve piston (flow limit valve), and thickness of washers determines cut-in range of pressure valve. Maximum pump pressure should not be more than 10% below the value stated on manufacturer's plate attached to pump.

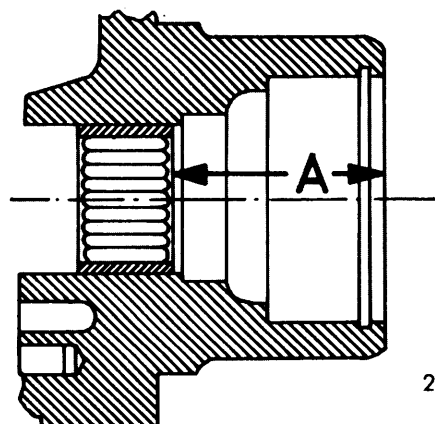

2BW41  
 $A = 1.457'' + .008'' (37 + 0.2 \text{ mm})$

NEEDLE ROLLER BEARING LOCATION

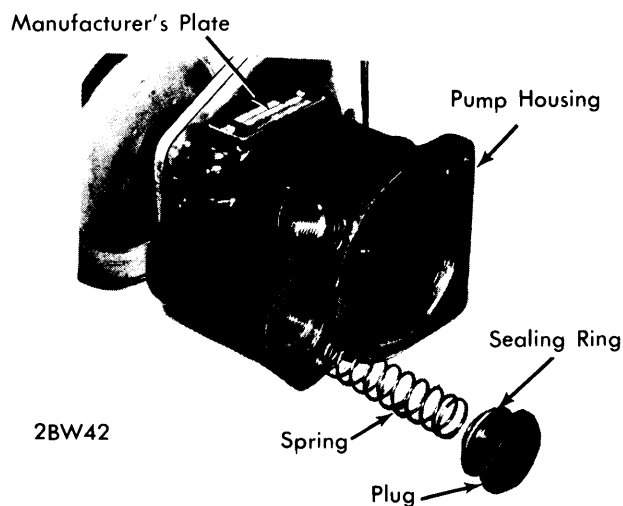

2BW42  
PUMP VALVE PLUG & SPRING

7) Clean power steering reservoir, wipe dry with lint free cloth, and install new filter element.

### REASSEMBLY

To reassemble, reverse disassembly procedure.

# Power Steering

## 1969-73 BMW POWER STEERING (Cont.)

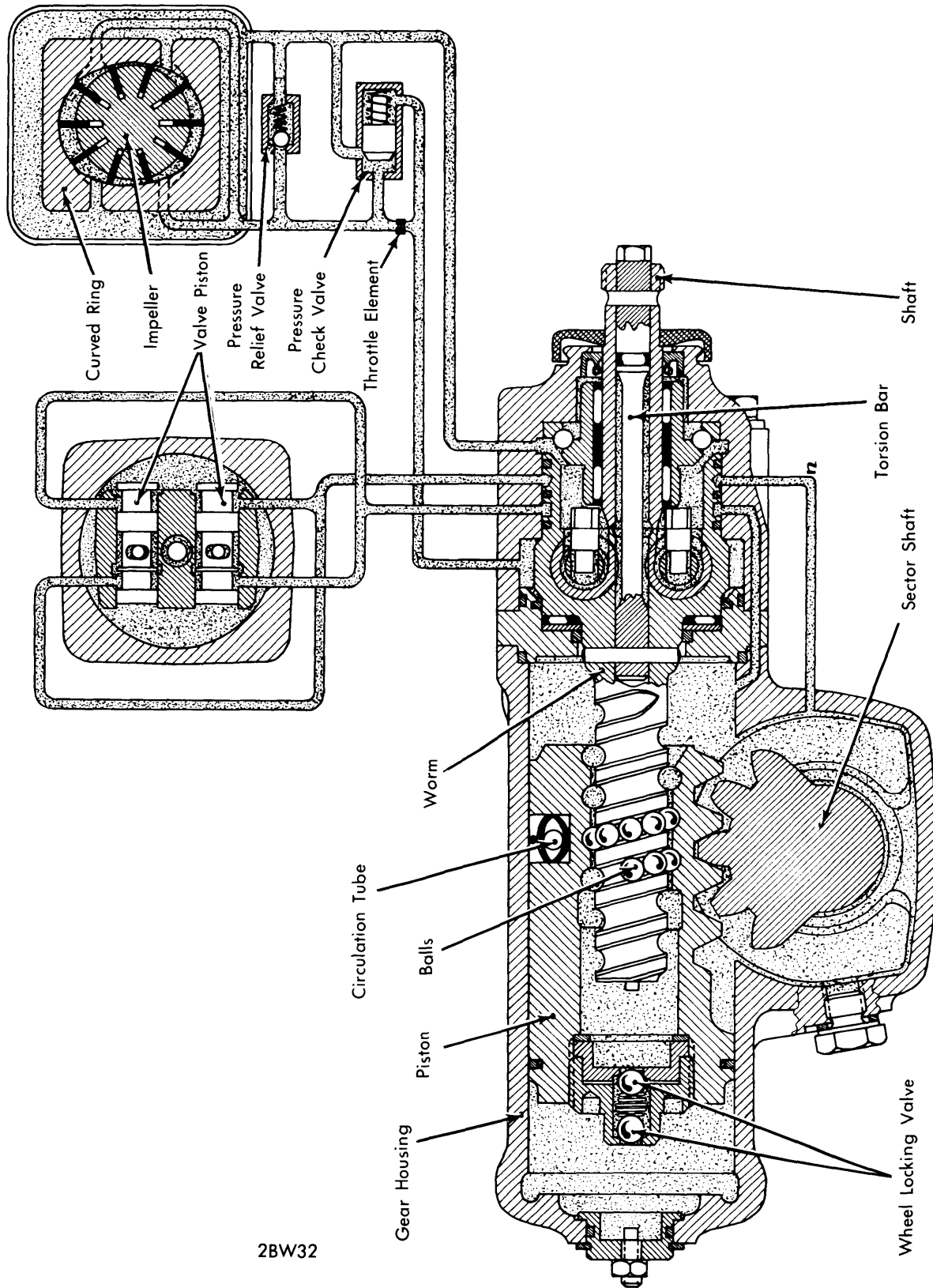

POWER STEERING GEAR (NEUTRAL POSITION)

## 1969-73 BMW POWER STEERING (Cont.)

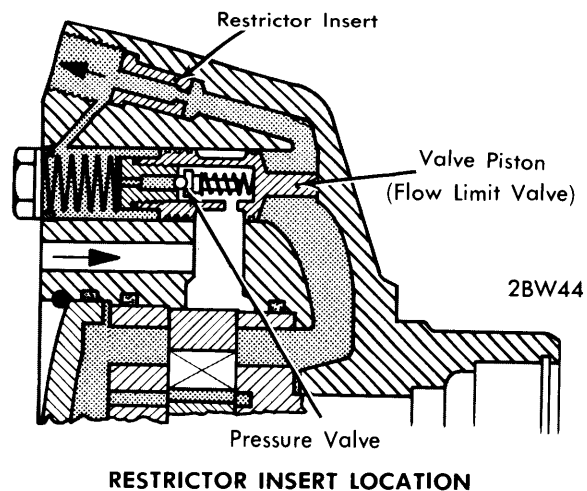
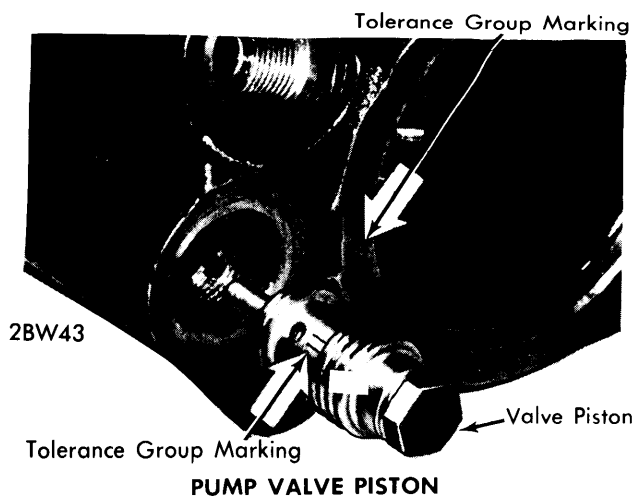

### ADJUSTMENT TORQUE

Application	INCH Lbs. (cmkg)
Worm in Piston.....	1.73-3.46 (2.0-4.0)
Worm Bearing in Valve Housing .....	1.30-2.16 (1.5-2.5)
Total For Worm Gear .....	3.46-5.20 (4.0-6.0)
Worm in Intermediate Housing .....	0.86-1.73 (1.0-2.0)

### TIGHTENING SPECIFICATIONS

Application	Ft. Lbs. (mkg)
Adjusting Screw Lock Nut .....	22 (3.0)
Valve Housing & Intermediate Cover .....	25 (3.4)
Universal Joint .....	18-20 (2.5-2.8)
Gear Housing .....	31-35 (4.3-4.8)
Steering Pump .....	16-17 (2.2-2.4)
Hose Connections.....	32-36 (4.5-5.0)
Pitman Arm.....	87-101 (12.0-14.0)