

1963-72 RENAULT

Dauphine 1094 (1963-66)
 Dauphine 1095 (1963-67)
 R-8 1130 (1963-67)
 R-8 1132 (1965-66)
 Caravelle 1131 (1963-65)
 Caravelle 1133 (1965-68)
 R-10 1190 (1967-69)
 R-10 1192 (1970-71)
 R-12 1172, 1331 (1971-72)
 R-15 1302 (1972)
 R-16 1152, 1153 (1969-72)
 R-17 1313, 1323 (1972)

DESCRIPTION

Vehicles are fitted with a rack and pinion type steering gear, which has direct steering linkage (tie rods) to each front wheel. Steering housing is mounted to the front crossmember and connected to the steering column through a flexible coupling. Rack incorporates a return assist spring on earlier models, while R-12 and later models have eliminated the use of this spring.

ADJUSTMENT

See Overhaul procedure in this article.

REMOVAL & INSTALLATION

STEERING GEAR

Removal — Raise and support front of vehicle. Remove the spare tire and both front wheels. Detach tie rod ends from steering knuckles, using suitable puller. Unbolt flexible coupling from pinion flange (two bolts on top side of coupling). If necessary, remove front brake hose. Remove nuts securing steering rack to crossmember. Pull assembly out either side of vehicle.

Installation — To install, reverse removal procedure, tighten all nuts and bolts. Adjust toe-in.

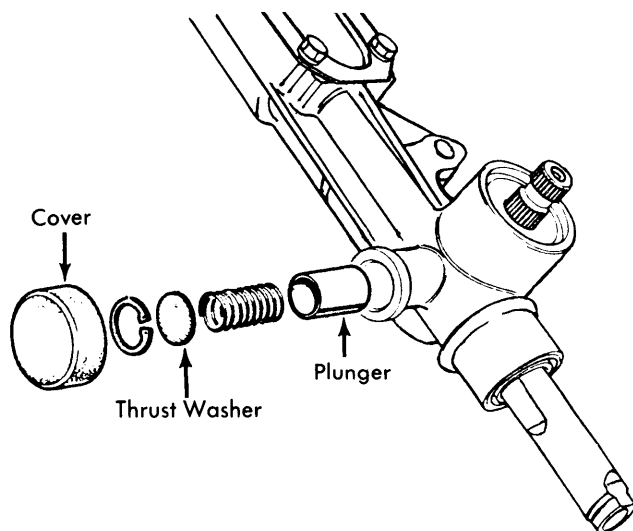

RACK DAMPER COMPONENTS

STEERING LINKAGE

Removal — Raise and support vehicle on side from which tie rod is to be removed. Remove spare tire and front wheel. Disconnect tie rod from steering arm either by breaking ball joint connection or by unpinning, as necessary. Loosen lock nut at end of rack. Unscrew tie rod, noting number of turns (for reassembly). Remove rubber bellows and securing collar.

Installation — Reverse removal procedure, noting the following: Do not tighten inner retaining nut until wheel alignment has been made. Use new lock washer for inner nut.

NOTE — It is imperative that tie rods be replaced on same, original side.

OVERHAUL

Disassembly — 1) Secure the steering assembly to a suitable holding tool clamped in a vise (keep rack in same relative position as on vehicle). Unlock and loosen inner tie rod ball joint retaining nut, or unpin tie rod eye end from steering arm. Unscrew tie rod, counting number of turns. Unclamp and pull off rubber bellows and securing plate.

2) From rack damper bore, remove circlip, thrust washer, spring, and damper plunger. Unscrew remaining two flexible coupling retaining bolts. Remove coupling and plates.

3) **NOTE** — Some models are equipped with pinion bearing preload adjusting screw positioned in center hole of flexible coupling. Extract screw as necessary to assist in disassembly. Unscrew pinion flange clamp pinch bolt, then remove clamp, upper circlip, safety washer, and spacer. Using a suitable extractor, remove sealing washer from around pinion. Withdraw circlip and washer from bore, then remove grease fitting from opposite side of housing.

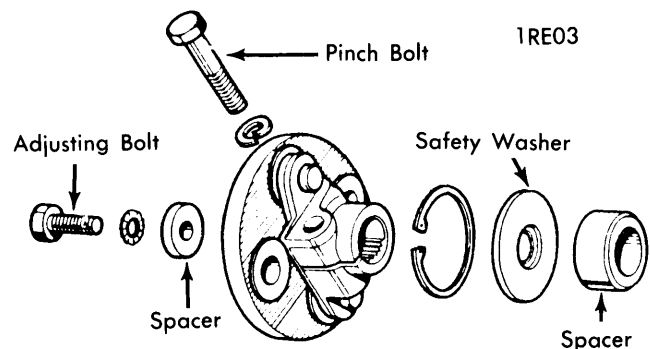

FLEXIBLE COUPLING WITH ADJUSTING BOLT

4) On early models, pinion may be punched out by inserting an awl through grease fitting hole and tapping lightly with hammer. On later models, or on those which do not have grease fitting on pinion bore, use a suitable extractor (Dir. 325) to pull pinion out of bore.

1963-72 RENAULT (Cont.)

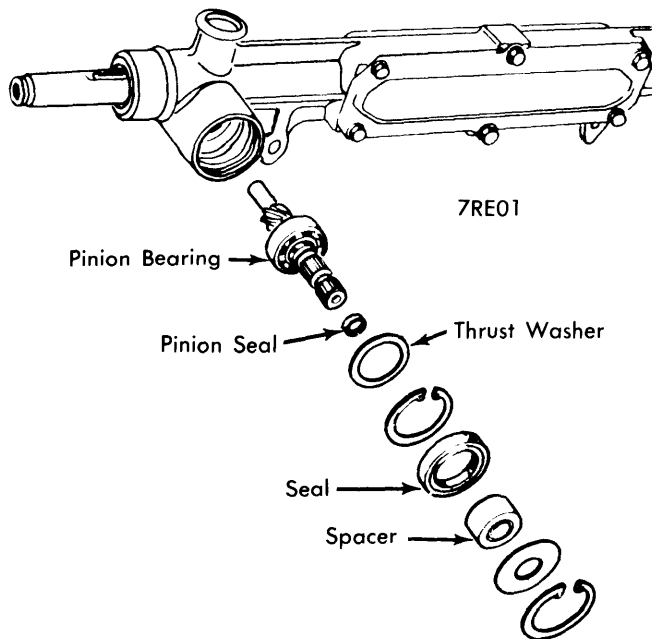

PINION ASSEMBLY REMOVED

Remove housing cover and gasket. Extract snap rings and spring seats as follows: For snap ring on outer end of rack, partially lift ring with screwdriver then turn rack with wrench to allow snap ring to free itself from groove. For snap ring at toothed end of rack (pinion end), pull rack toward you from toothed end; snap ring will free itself from groove. Discard all snap rings, circlips, and gasket. Withdraw return spring, spring seats, and rubber ring (if equipped). Extract lower pinion bearing bushing.

6) Use a press and mandrel to remove both rack bearing bushings. *NOTE - Even if bushings do not require replacement, remove bushing at outer end (opposite pinion end) to assist reassembly.*

Reassembly & Adjustment - 1) Insert lower pinion bearing bushing. Fill space behind bushing with suitable gear grease. If equipped, insert rubber ring into rack spring and position spring, with seats, into housing. Install new snap ring on rack outer end. Insert rack into housing with new pinion end snap ring. Replace housing cover and gasket after filling housing with suitable grease. Replace rack outer end bushing.

2) Place a new circlip or thrust washer (as equipped) on pinion. Press bearing onto pinion, followed by sealing washer (seat in groove). Insert pinion assembly into housing with flat of shaft on pinion damper side. Install remaining pinion components in the following order: Thrust washer, new circlip, new sealing washer, spacer, safety washer, and new upper circlip.

3) On early models without pinion adjusting screw, it is necessary to use a suitable clamp-type hand press (Dir. 19) to set pinion assembly in bore and adjust preload, as follows: Position pinion drive flange without tightening set bolt. Align two flange bolt holes perpendicular with rack centerline. Position clamp as illustrated. Operate press with a force of 55-60 lbs. to push pinion assembly into position. Fit plunger, spring, thrust washer, and new circlip into rack damper bore. Compress components into place by means of screw on top of hand press.

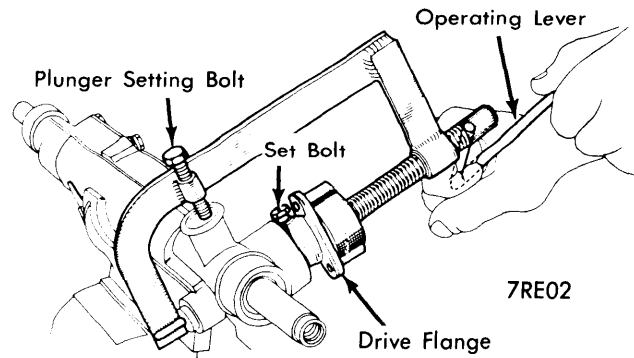

ASSEMBLING PINION & DAMPER

4) On later models with pinion adjusting screw, use a suitable installer/extractor (Dir. 325) to set damper assembly in bore (this is done after pinion assembly is installed).

5) On early models, adjustment of pinion end play is also done using the hand press tool. Refer to illustration while making adjustment as follows: Apply pressure on drive flange by pushing on operating lever until it contacts tool screw head. Tighten drive flange set bolt to 15-20 ft. lbs. Remove hand press. Screw grease fitting into housing.

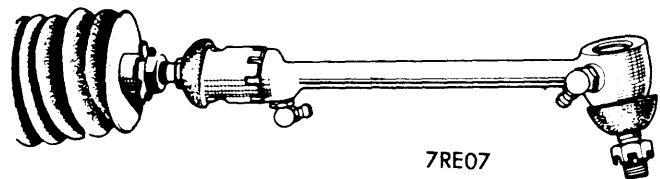

TIE ROD WITH INNER BALL JOINT CONNECTION

6) On later models, attach a torque wrench to adjusting screw head and turn to right until rack rests against stop, then tighten flange set bolt to 10 ft. lbs.

7) Position flexible coupling, with two plates, to drive flange. Install two securing bolts (nuts face gear housing).

8) Position and clamp inner end of rubber bellows. Install outer securing collars. Screw tie rod end into rack, using same number of turns as during removal (tie rods should be fitted with new locking rings). Do not tighten locking nuts until wheel alignment is made.

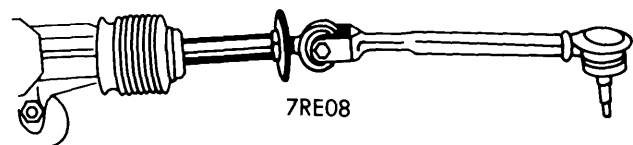

TIE ROD WITH EYEBOLT TYPE INNER CONNECTION

TIGHTENING SPECIFICATIONS

Application	Ft. Lbs.
Rack Assembly-to-Crossmember.....	20-30
Flexible Coupling-to-Flange.....	10
Tie Rod-to-Steering Knuckle.....	25-30