

914 (1970-73)  
914/6 (1970-71)

### DESCRIPTION

Vehicles use a rack and pinion type steering gear, which is mounted in rubber insulators. Movement of steering wheel is transmitted through the steering shaft to the drive pinion. The turning motion of the pinion engages the rack teeth, causing the rack to move laterally, affecting a change in steering knuckle position, thereby turning front wheels.

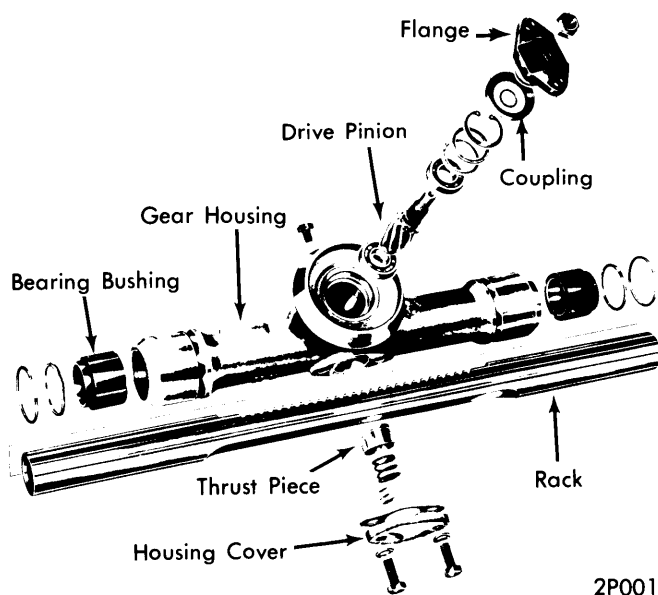

RACK & PINION ASSEMBLY

### ADJUSTMENT

**NOTE** — Adjustment for Porsche 914 & 914/6 steering gear is included in "Overhaul" procedure.

### REMOVAL & INSTALLATION

**NOTE** — If steering shaft bearing is to be replaced during this procedure, first remove fuel tank.

**Removal** — 1) Remove bottom bolt from lower universal joint and loosen nuts on track rod joints. Remove ball joints. Remove front axle underfloor protector. Loosen steering gear bolts on auxiliary carrier.

2) Unscrew torsion bars and remove seals, then remove auxiliary carrier, steering gear and track rods. Detach fork-type joint from track rod.

**Installation** — 1) Replace ball joints and tighten to specifications. Reseat bellows. Lubricate needle bearing on shaft and position in gear. **CAUTION** — When installing gear, steering shaft must first be inserted into lower universal joint such that hex screw installation is possible. Universal joint connection is not possible if gear is already in position.

2) Install auxiliary carrier (check for proper body pin fit). Use new spring washers for gear retaining bolts and torque to specification. Push transverse control arm down against stop in shock absorber, pushing adjusting lever as close as possible against stop on auxiliary carrier.

3) Torque retaining bolts for bottom universal joint (in passenger compartment). Detach protective member on front transverse control arm bearing and check for correct seat of closing cover, then replace member.

### OVERHAUL

#### STEERING GEAR

**Disassembly** — Place gear in padded vise and remove housing cover, lock ring, and compensating washer. Screw hex nut on drive pinion and use as aid for prying out pinion. Remove bearing bushing, then extract bearing.

**Reassembly** — During assembly, coat all components and pack gear (0.9 oz. capacity) with suitable lubricant. Adjust play of thrust piece. Measure distance of thrust piece up to housing support surface and measure recess in housing cover. Dimension of housing cover recess must be .008" greater than distance from thrust piece to housing support surface. Compensate difference by means of adjusting shims (thrust piece should have .008" play when cover is installed). Check steering gear starting torque at pinion flange: approximately 5-7 INCH lbs. should be obtained.

#### EYEBOLT

**CAUTION** — Eyebolts must be installed in precise position to ensure free movement of steering components and exact guiding of track rod.

**Disassembly** — Clamp gear into suitable holding tool (P-285b), without washers. Remove clamps on outer end of bellows and pull bellows off holder. Loosen bellows holder with hook spanner and unscrew eyebolt and bellows holder.

**Inspection** — Check eyebolts, bellows and clamps for visible wear. Replace as required.

**Reassembly** — Mount bellows on housing. Screw bellows holder on eyebolt. Coat eyebolt threads and rack face end with suitable sealer. Install eyebolts. Attach steering gear without washers to original holding tool (P-285b). Locating pins should slide easily into eyebolts with flattened end resting against outer pin. Tighten bellows holder. Clamp bellows in position.

## 1970-73 PORSCHE 914 & 914/6 (Cont.)

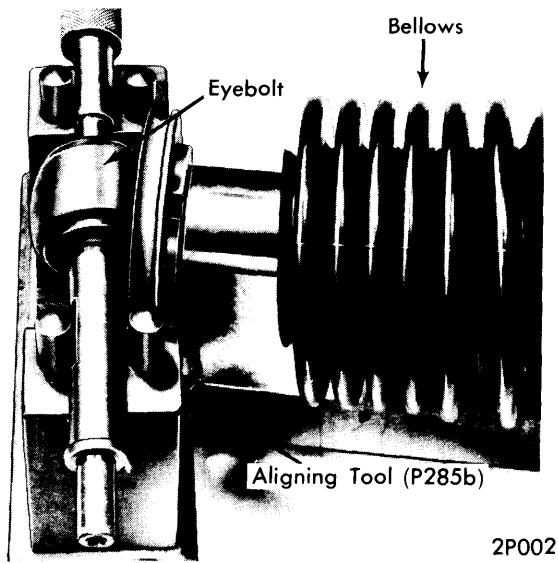

**EYEBOLT ALIGNMENT**

2P002

### TIGHTENING SPECIFICATIONS

Application	Ft. Lbs. (mkg)
Steering Gear Housing Cover .....	11 (1.5)
Housing Filler Bolt .....	11 (1.5)
Pinion Coupling Flange .....	34 (4.7)
Dust Boot Retainer for Universal Bushing .....	50 (6.9)
Fork (Joint Bushing) .....	34 (4.7)
Shaft-to-Coupling .....	18 (2.5)
Gear-to-Auxiliary Support .....	34 (4.7)
Ball Joint-to-Tie Rod End .....	32 (4.4)
Bottom Universal Joint (On Shaft) .....	18 (2.5)
Tie Rod Clamp .....	11 (1.5)
Steering Wheel Nut	
914 .....	36 (4.5)
914/6 .....	54 (7.5)