

## 1966-72 OPEL

Opel (1966-72)

## DESCRIPTION

## STEERING GEARS

Steering assembly is the rack and pinion type and is held to the crossmember by rubber bushings and clamps. Steering gear pinion shaft moves the rack to the left or right thereby transmitting the turning motion of the steering wheel to the tie rods and steering arms. The rack is seated in the long neck of the steering gear housing in a self lubricating sintered metal bushing.

## STEERING LINKAGE

Tie rods are connected to both rack ends by a ball joint on all models except 1971-72 Opel 1900, which uses an axial joint. Two rubber bellows between ball joints (Axial) and steering gear housing protect rack and ball against dirt, dust and mud. Ball joints of the tie rod do not require service.

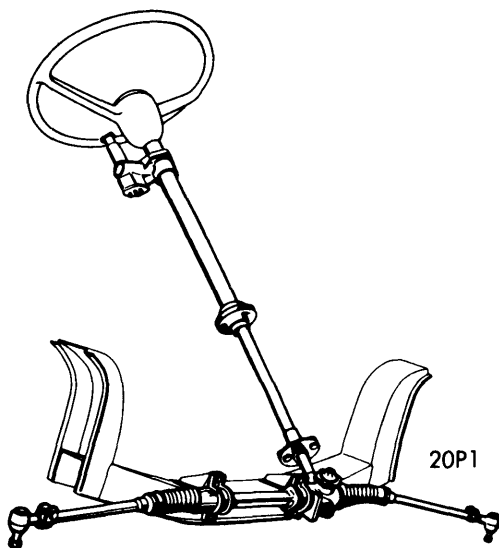

STEERING COLUMN ASSEMBLY WITH GEAR

## ADJUSTMENT

Adjustment of steering gear assembly is accomplished by turning the adjustment screw in or out. Positioning of the adjustment screw exerts a pressure on the rack, thereby varying the backlash between pinion and rack.

1) Set steering gear to high point by positioning front wheels straight ahead with steering wheel centered. *NOTE* — Flexible coupling bolt hole will be positioned horizontal (or parallel) to the rack.

2) Turn adjusting screw into steering gear housing until a resistance is felt. On 1966-67 models, back off adjusting screw 1/2 of a turn or until rack is just freely moving and tighten lock nut to a torque of 65 ft. lbs. On 1968-72 models, back off adjusting screw 1/8-1/4 of a turn and tighten lock nut to a torque of 43 ft. lbs.

3) Lubricate area under pinion shaft rubber boot with steering gear lubricant, slide boot into position.

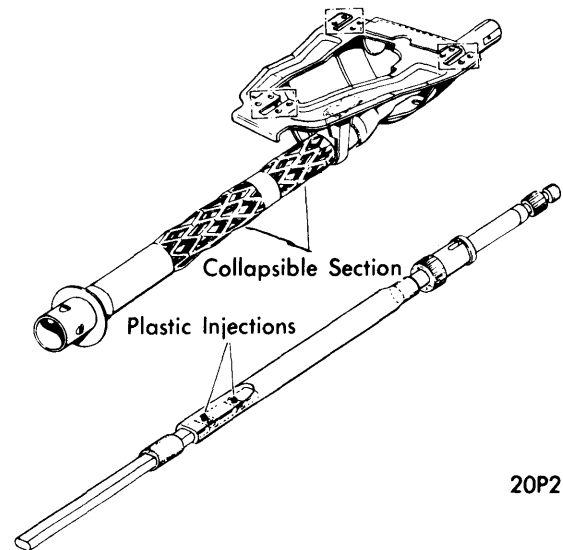

ENERGY ABSORBING STEERING COLUMN

## REMOVAL &amp; INSTALLATION

**Removal** — 1) Remove rubber knee protector pad or guard plate from lower deflector panel and both side members, if so equipped.

2) Loosen clamp securing flexible coupling to steering shaft. Remove stop bolt from steering column and pull steering wheel rearward, (exc. Opel 1900). Remove right and left tie rod end cotter pins and nuts.

3) Using a suitable remover (J-21687), press ball studs from steering arms. Remove four attaching bolts securing steering gear to front suspension crossmember and lift off steering gear assembly and tie rods.

**Installation** — Reverse removal procedures. Note the following: Set steering gear to high point prior to installing on Opel 1900 models. Turn steering wheel so that flat or cutout surface on lower portion of steering shaft is parallel to flexible coupling bolt hole. *NOTE* — Adjust dimension between steering wheel hub and turn signal switch housing cover to 3/32-1/8" when installing lower end of steering mast shaft into the flexible coupling.

## OVERHAUL

## STEERING GEAR

**Disassembly (Exc. 1900)** — 1) Clamp steering gear assembly in padded vise and remove wire clamps and rubber bellows. Remove rod ball studs from racks, adjusting screw from steering gear housing, thrust spring and sintered bronze shell.

2) Remove pinion nut, flat washer and special washer. Discard pinion nut. Remove pinion shaft and rack assembly, "O" rings from retainer and pinion bushing and thrust washer.

## 1966-72 OPEL (Cont.)

**Disassembly (1900)** — Clamp steering gear assembly in padded vise and remove left and right tie rod end from axial joint (lock nut). Remove wire clamps and rubber bellows from steering gear housing and axial joint. Remove ball stud of axial joint from rack, adjusting screw, thrust spring and bearing shell. Remove sheet metal cap and pinion nut from pinion. Pull pinion and rack from housing. **CAUTION** — Do not turn pinion in end position.

3) Install special washer, flat washer and new pinion nut. Torque to specifications. Install sintered bronze shell. Fill adjusting hole with suitable lubricant. Install thrust spring, adjuster screw and lock nut. Install rubber bellows, wire clamps and tie rods using new lock plates. Adjust steering gear as outlined under steering gear adjustment.

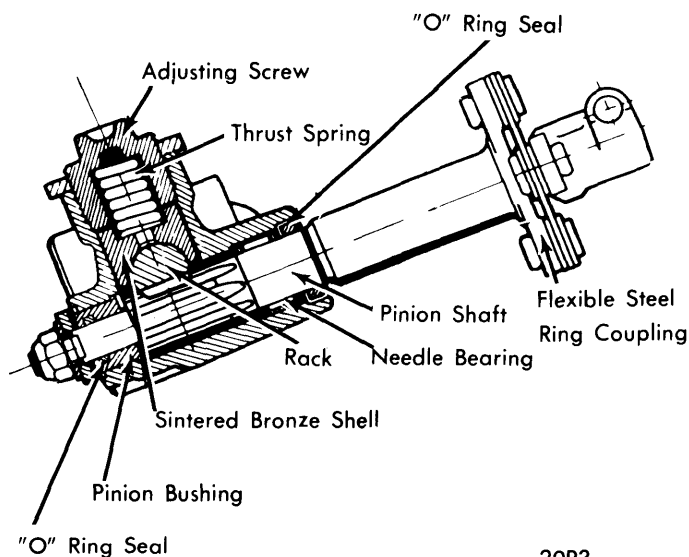

20P3  
**STEERING GEAR ASSEMBLY (END VIEW)**

**Inspection** — Check all parts for wear or damage. If rack teeth are damaged, replacement of complete steering gear assembly is required. Check to ensure that three air channels of sintered metal bushing are not obstructed by lubricant. **NOTE** — Channel obstruction could cause rubber bellows to jam into rack teeth.

**Assembly (All Models)** — 1) With steering assembly in vise, install new "O" rings on retainer and pinion bushing, then install thrust washer on pinion bushing. **NOTE** — Coat all moving parts with steering gear lubricant during installation. Fill long end of housing with approximately 1-3/4 oz. steering gear lubricant.

2) Center long toothless end of rack into short end of housing (2-7/8") on each end protruding. Mesh pinion shaft to twelfth tooth of rack in gear assembly. **NOTE** — Ensure pinion is positioned so that bolt hole in pinion shaft flexible coupling is on top and horizontal with rack.

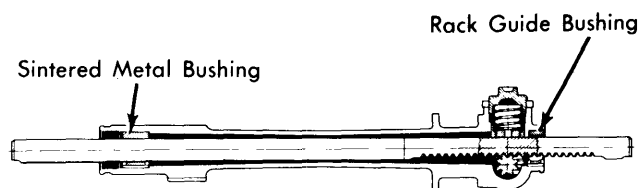

20P4

**STEERING GEAR ASSEMBLY (FRONT VIEW)**

### TIGHTENING SPECIFICATIONS

Application	Torque (Ft. Lbs.)
Tie Rod Ball Nut to Rack	
(1966-67) .....	40
(1968-72) .....	43
Steering Gear Housing to Crossmember	
(1966-67) .....	30
(1968-72) .....	18
(1971-72) 1900 .....	22
Pinion Nut	
(1966-67) .....	10
(1968-72) .....	11
Upper Control Shaft Nut	
(1966-67) .....	30
(1968) .....	33
Adjusting Screw Lock Nut	
(1966-67) .....	65
(1968-72) .....	43
Tie Rod to Steering Arm	
(1966-67) .....	30
(1968-72) .....	29
Flexible Coupling Clamp Nut	
(1970-72) exc. 1900 .....	15
(1971-72) 1900 .....	22
Ball Stud Nut (Axial) .....	47
Tie Rod Lock Nut	
(1971-72) 1900 .....	49