

1963-73 SAAB

All Models (1963-73)

DESCRIPTION

Steering column consists of an upper and lower shaft connected by a flexible joint. The upper shaft is covered by a column tube. Later models are of the telescopic type.

REMOVAL & INSTALLATION

95 & 96 SPORT & MONTE CARLO (1963-72)

Removal - 1) Remove steering wheel and horn button assembly. Remove clamp screw at column-to-steering gear pinion connection. Remove nut from upper end of gearshift shaft "U" joint and drive out taper pin using suitable drift (784083). If equipped, remove return spring above joint.

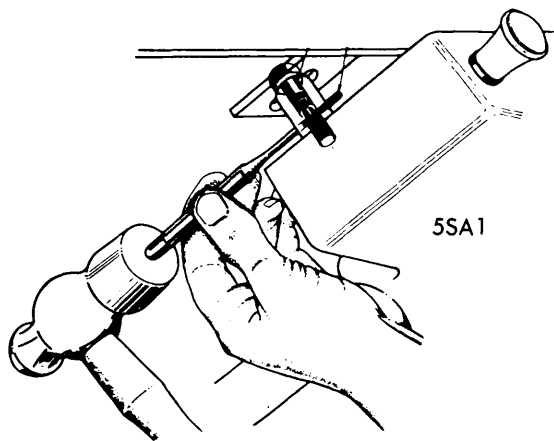

REMOVING LOCKING PINS

2) After driving out locking pins, remove screws for steering column stand. Remove column, complete with gearshift shaft and lever. Pull column out of its bearing and remove the two rubber bushings together with steering column bushings. Remove cardboard sleeve between bushings and if necessary, remove wiring.

Installation - To install, reverse removal procedure. *NOTE* - The upper rubber bushing is thinner than lower one. Both bushings are tapered and must be installed so that screws on locating lug point toward steering wheel.

99 MODELS (1969-72)

Removal - 1) Remove lock screw at joint, remove retaining screws at pedal bracket and at instrument panel. Disconnect quick release connector and lift out steering column assembly.

2) Remove retaining screws from plastic cover under steering wheel and pull column out of tube. Remove two rubber bushings with washers and column shaft bushings. *NOTE* - Collapsible steering column must be handled with care. Do not jolt or hammer column. The steering wheel must not be hammered on and splines should slide freely.

Installation - To install, reverse removal procedure. Tighten all nuts and bolts.

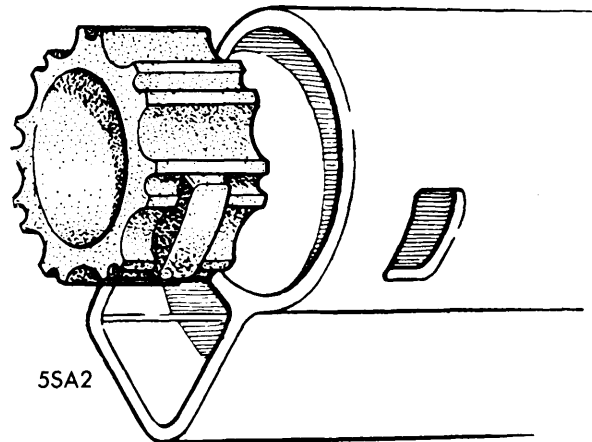

STEERING COLUMN BUSHINGS

SONETT MODELS (1967-70)

Removal - Pry off horn button and remove cable. Cut cable below steering shaft. Remove safety pad and cable. Remove lock screw at lower joint and covers of steering column together with flasher and windshield wiper switch. Remove ignition, starter and buzzer contacts. Pull speedometer cable through from engine compartment, then remove the two retaining screws of steering column and remove column.

Installation - To install, reverse removal procedure. Tighten all nuts and bolts.

SONETT MODELS (1971-73)

Removal - Remove steering column cross support strap. Pull out steering shaft from steering gear pinion. Then remove steering column assembly.

Installation - To install, reverse removal procedure. Tighten all nuts and bolts.

C - 1963-67 WHEEL & HORN BUTTON

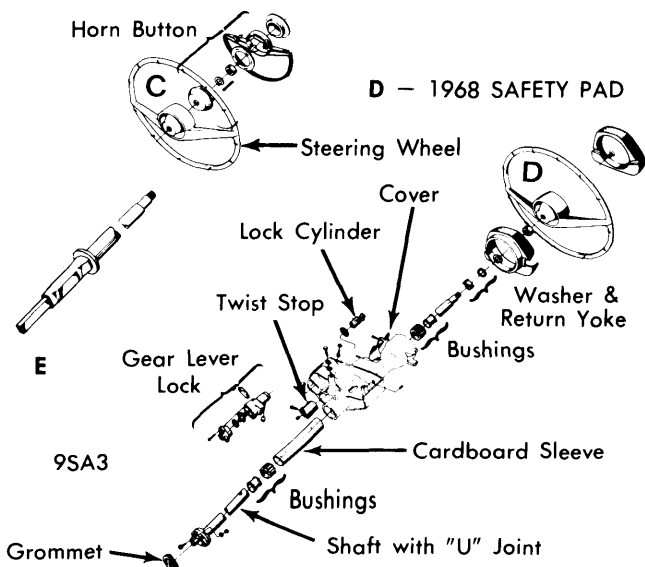

E - 1969-73 STEERING SHAFT

STEERING COLUMN & STEERING WHEEL