

1971-72 PLYMOUTH CRICKET

Cricket (1971-72)

DESCRIPTION

Steering column is of the conventional type. The shaft is encased in a mast jacket and the assembly is attached to the instrument panel by support brackets. At the lower end the steering shaft is connected to the rack and pinion steering gear through a universal joint and intermediate shaft.

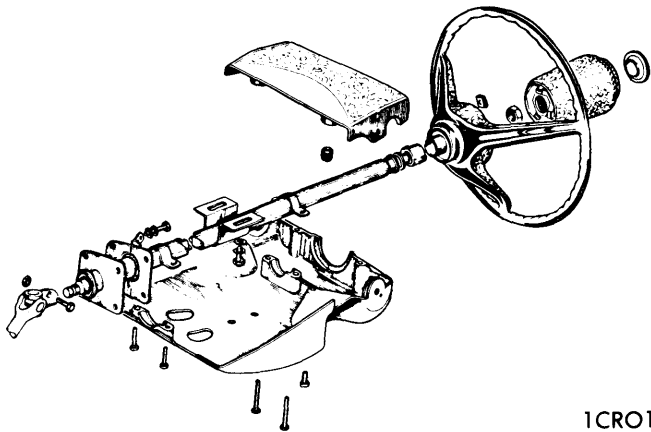

CRICKET STEERING COLUMN

1CRO1

REMOVAL & INSTALLATION

Removal – 1) Disconnect battery ground cable. Unlock steering column. Remove column cover and indicator switch. Remove floor opening plate. Note position of ground lead and unbolt steering support bracket. Mark relative position of column to intermediate shaft. Separate column from shaft.

2) Mark relative position of column to intermediate shaft. Separate column from intermediate shaft and draw column inside car. Remove steering shaft from bottom of column jacket, using steering lock boss to push out bottom bushing.

Installation – To install, reverse removal procedure. *NOTE* – Lubricate column top bearing before replacement (SAE 90).

TIGHTENING SPECIFICATIONS

Application	Ft. Lbs.
Steering Wheel Nut.....	32
Intermediate Shaft-to-Column.....	15