

Steering Wheel Removal

1962-70 SIMCA

Simca 1000 (1962-68)
 Simca 1189 (1969)
 Simca 1204 (1969-70)

HORN BUTTON & STEERING WHEEL

All Models – Pry out horn cap (steering wheel center cover), mark position of steering wheel on steering shaft. Remove horn control circlip and steering wheel retaining nut. Remove horn control bracket and spring. Remove steering wheel (if necessary, tap steering wheel on underside to assist in removing).

TURN SIGNAL SWITCH

All Models – Remove steering wheel. Remove two attaching screws of combined turn signal switch and unhook both electric connection boxes from steering column, then slide out combined switch. Loosen lock screws of retaining plate-collar of flexible bushing and attaching screw of retaining plate. Remove retaining plate, housing with wires, and combined switch. To install, reverse removal procedures. Torque steering wheel nut to specifications.

1970-71 SUBARU

Subaru 1100 (1970-71)
 Subaru 1300 (1971)

HORN CONTROL & STEERING WHEEL

1) Disconnect battery. Disconnect horn, turn signal, dimmer switch, and stop light switch wiring from wiring harness connectors on lower side of instrument panel. Unscrew the two set screws retaining horn bar, then slide bar to left or right while forcibly pressing down on it and remove from steering wheel. Mark steering wheel and shaft for reassembly reference, then remove steering wheel.

2) Remove the two stopper screws from steering wheel and disassemble spring, contact, and stopper. Remove the three screws from horn ring assembly, and disassemble cap, pad, and horn ring. To install, reverse removal procedure.

TURN SIGNAL SWITCH

Switch is a combination turn signal, hazard warning, and headlight dimmer assembly. Remove steering wheel as outlined above. Remove the two combination switch retaining screws, then remove the contact plate assembly, washer, cancel cam, combination switch, and spacer from the shaft (in this order). To install, reverse removal procedure.

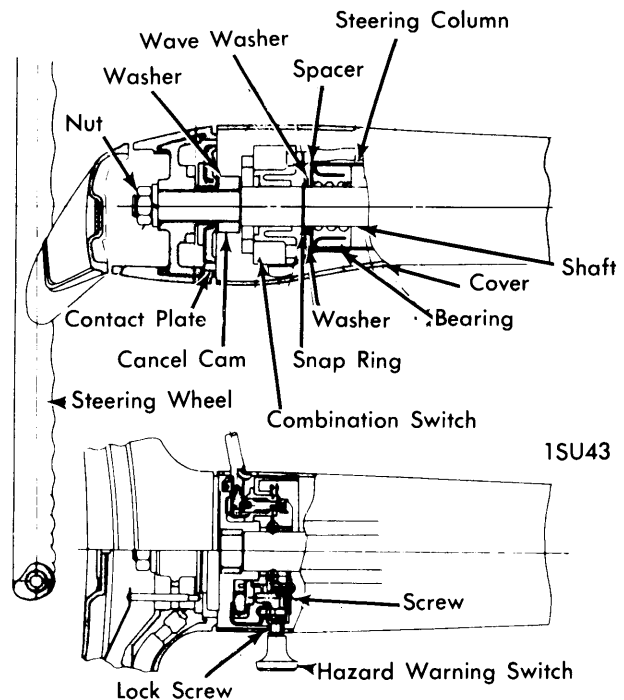

STEERING WHEEL & UPPER ASSEMBLY

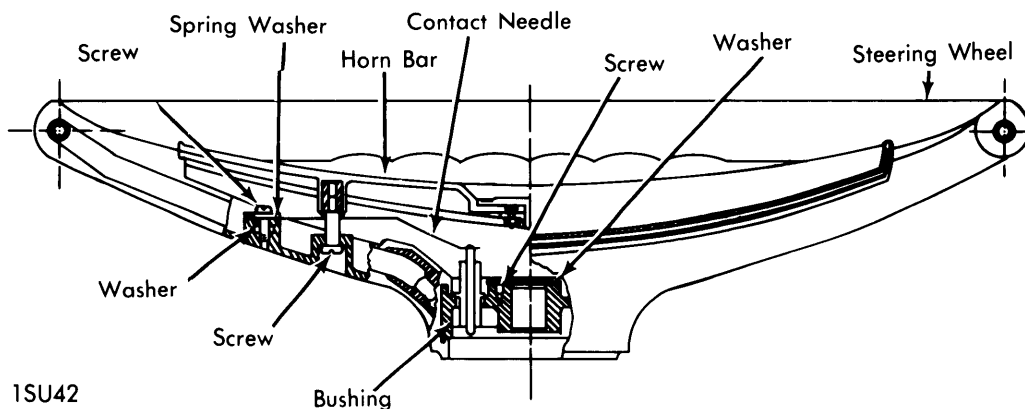

STEERING WHEEL ASSEMBLY