

1966-70 ROVER 2000

2000 (1966-70)

HORN BUTTON & STEERING WHEEL INSTALLATION

HORN BUTTON

Remove two Allen screws (early models) or self-locking screws (late models). Lift off horn bar. To install, reverse removal procedure.

STEERING WHEEL

With horn bar removed, remove steering wheel nut and lock washer. Pull steering wheel off of steering shaft. To install, reverse removal procedure.

TURN SIGNAL

With steering wheel removed, spring off plastic cover from steering column nacelle. Disconnect wires from switches and remove switches. To install, reverse removal procedure.

1971-72 ROVER 3500S

3500S (1971-72)

STEERING WHEEL

Removal – Pry off motif plate in center of steering wheel. Remove steering wheel nut and lock washer. Mark steering wheel position for reassembly. Pull steering wheel off of steering shaft. To install, reverse removal procedure.

HORN, TURN, HEADLIGHT FLASHER SWITCHES

Removal – With steering wheel removed, spring off plastic cover from steering column. Disconnect wiring at switches. Remove screws attaching switches. To install, reverse removal procedure.

NOTE – Switch lever on right-hand side of steering column incorporates horn and turn signal. Switch on left-hand side is head light flasher switch.

1963-73 SAAB

All Models (1963-73)

HORN BUTTON & STEERING WHEEL REMOVAL

95 & 96 Sport & Monte Carlo (1963-67) – Disconnect horn wire at connector under instrument panel. Remove horn button by prying gently under edge of button. Disconnect horn wire from contact plate. Loosen and remove nut and retaining washer. Remove horn ring and lift off steering wheel. The return yoke for turn signal switch may now be removed.

95 & 96 Sport & Monte Carlo (1968-69) – Remove safety pad by turning it counterclockwise. Remove nut and spring washer. Lift off steering wheel. The return yoke for turn signal switch may now be removed.

95 & 96 Sport & Monte Carlo (1970-73) – Remove steering wheel pad and horn button by removing 4 screws under steering wheel spokes. Remove nut and spring washer and lift off steering wheel. The return yoke for turn signal may now be removed.

99 Models (1969-73) – 1) Remove steering wheel pad. On 1969 models, pad is retained by one screw. Access to screw is achieved by prying plug from center of steering wheel pad. On all other models, remove 4 screws under spokes to remove pad.

2) Remove horn contact finger and bottom cover from steering wheel by removing screws. Remove steering wheel nut and washer. Using suitable puller (819568), pull off steering wheel. If necessary, turn signal switch actuator can now be removed.

Sonett Models (1971-73) – Pry off horn button with fingers and disconnect horn wire. Remove safety pad by turning it counterclockwise. Remove nut and spring washer. Lift off steering wheel. The return yoke for the turn signal switch can now be removed.

All Models – To install reverse removal procedure. When replacing steering wheel, make sure that switch actuator centerline coincides with centerline of switch housing when wheels are straight ahead. Make sure that clearance between return yoke and projection at turn signal switch is .008-.024" (.2-.6 mm) with switch in neutral position. Adjust by placing shims between switch and column stand.

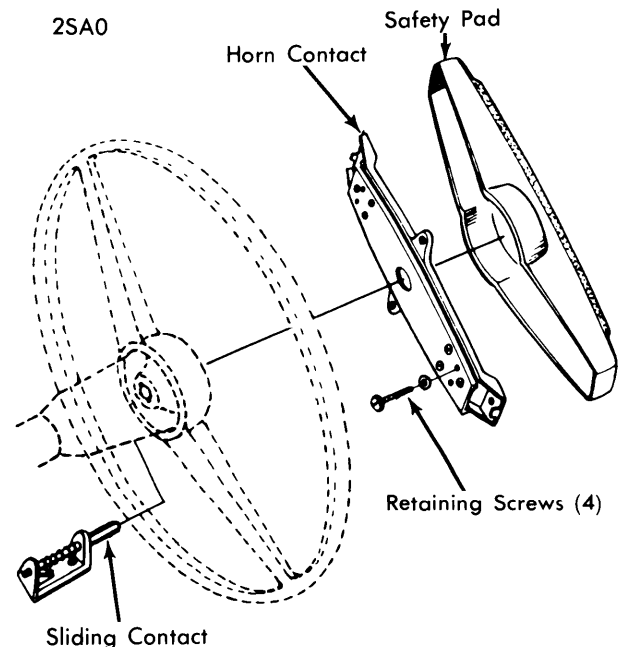

1970 STEERING WHEEL & SIGNAL DEVICE (TYPICAL)