

Steering Wheel Removal

1963-73 FIAT

All Models (1963-73)

HORN BUTTON & STEERING WHEEL

Remove battery cables. Pry off or unscrew horn button (center emblem) as necessary. Remove horn cable. On 128 models it will be necessary to remove steering column cover. On all models, unscrew steering wheel retaining nut and pull off steering wheel.

TURN SIGNAL SWITCH

After removing steering wheel as described, disconnect turn signal switch electrical wiring, loosen switch retaining nut (or screws), and remove switch from steering column.

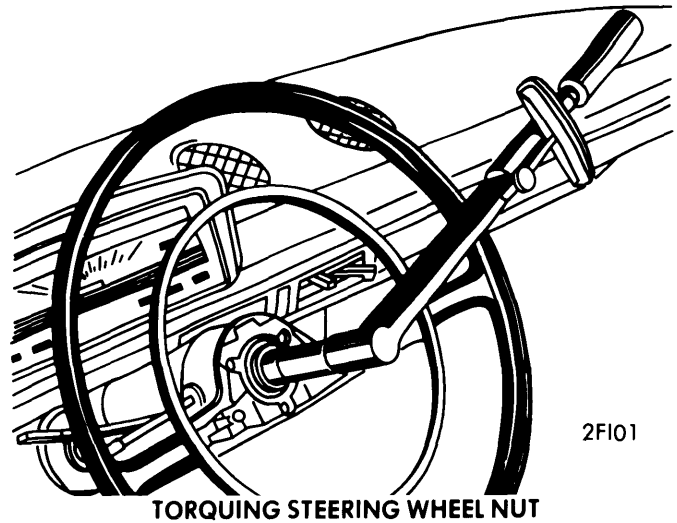

1971-72 HONDA 600

600 (1971-72)

TURN SIGNAL SWITCH

HORN BUTTON & STEERING WHEEL

All Models – Remove center pad from steering wheel, disconnect horn cable, then unscrew wheel retaining nut. Remove center horn switch plate by removing two screws on either side of shaft. Using suitable tool, pull steering wheel (and wheel hub on Coupe models). Remove cancelling cam and spring.

All Models – After removal of steering wheel, unscrew column cover retaining screw. Separate cover, loosen center screw on switch assembly completely. Tap top of screw with screwdriver to detach switch from column. Remove washer and wiper switch as an assembly from turn signal switch. To install, reverse removal procedures.

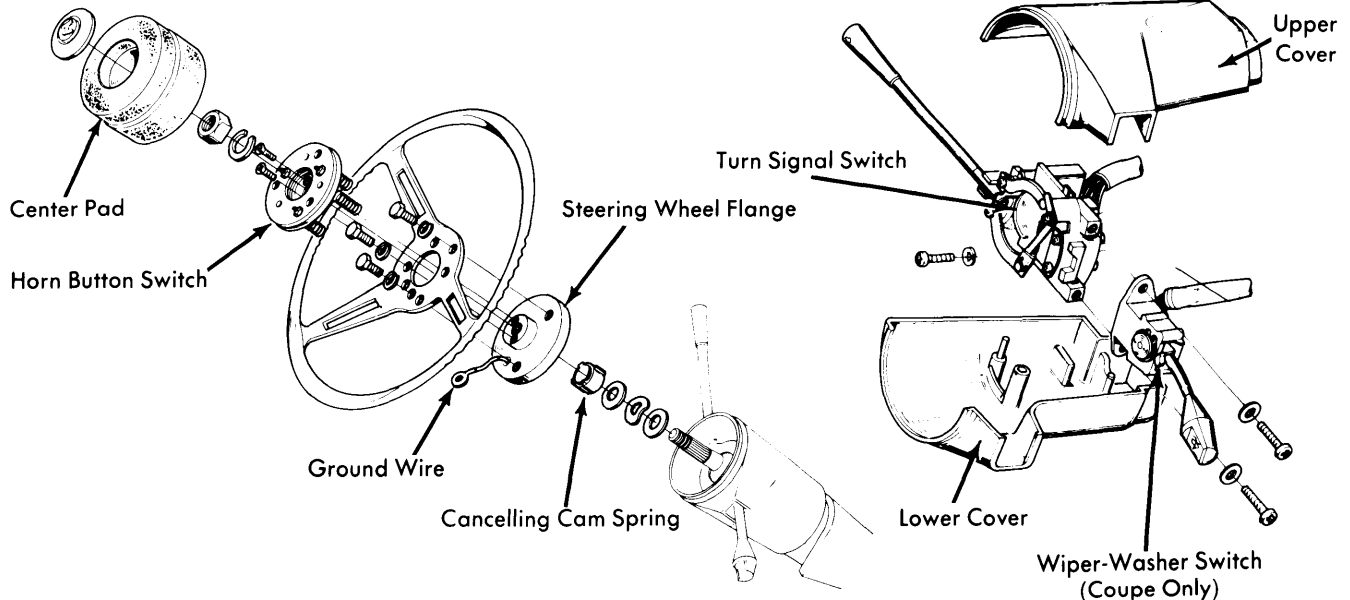

2HO01

**HONDA HORN BUTTON, STEERING WHEEL & TURN SIGNAL SWITCH (TYPICAL)
(COUPE SHOWN)**